

**EXCAVATIONS IN THE CANONGATE BACKLANDS,  
EDINBURGH**

John Gooder, with contributions from Clare Ellis,  
George Haggarty, Andrew Heald, David Henderson,  
Dennis B Gallagher, Nicholas N McQ Holmes, Jill Turnbull  
and Patrice Vanderpe

**Scottish Archaeological Internet Report 56, 2013**

**[www.sair.org.uk](http://www.sair.org.uk)**

Published by the Society of Antiquaries of Scotland, [www.socantscot.org.uk](http://www.socantscot.org.uk)  
with Historic Scotland, [www.historic-scotland.gov.uk](http://www.historic-scotland.gov.uk)  
and the Archaeology Data Service, [www.archaeologydataservice.ac.uk](http://www.archaeologydataservice.ac.uk)

Editor Helen Bleck  
Produced by Archétype Informatique SARL, [www.archetype-it.com](http://www.archetype-it.com)

DOI: 10.9750/issn.1773-3808.2013.56

Requests for permission to reproduce material from a *SAIR* report should be sent to the Director of the Society of Antiquaries of Scotland, as well as to the author, illustrator, photographer or other copyright holder.

Copyright in any of the *Scottish Archaeological Internet Reports* series rests with the SAIR Consortium and the individual authors.

The maps are reproduced from Ordnance Survey material with the permission of Ordnance Survey on behalf of The Controller of Her Majesty's Stationery Office. © Crown copyright 2001. Any unauthorised reproduction infringes Crown copyright and may lead to prosecution or civil proceedings. Historic Scotland Licence No. GD 03032G, 2002.

The consent does not extend to copying for general distribution, advertising or promotional purposes, the creation of new collective works or resale.

---

# CONTENTS

---

<b>List of Illustrations</b> . . . . .	<b>iv</b>
<b>List of Tables</b> . . . . .	<b>v</b>
<b>1 Abstract</b> . . . . .	<b>1</b>
<b>2 Introduction</b> . . . . .	<b>2</b>
<b>3 Historical Background</b> . . . . .	<b>3</b>
<b>4 Holyrood Development North Site, Plot N, Holyrood Road</b> . . . . .	<b>4</b>
4.1 Location . . . . .	4
4.2 Earlier archaeological investigations . . . . .	4
4.3 Excavation results . . . . .	4
<b>5 Calton Road</b> . . . . .	<b>12</b>
5.1 Location . . . . .	12
5.2 Earlier archaeological investigations . . . . .	12
5.3 Excavation results . . . . .	12
<b>6 Post-Excavation Analyses</b> . . . . .	<b>15</b>
6.1 Ceramic material, by George Haggarty . . . . .	15
6.2 Coin, by Nicholas N McQ Holmes . . . . .	20
6.3 Clay tobacco pipes, by Dennis B. Gallagher . . . . .	21
6.4 Animal bone, by David Henderson . . . . .	26
6.5 X-ray diffraction of Calton Road bone, by Clare Ellis . . . . .	29
6.6 Metal and slag, by Andrew Heald and Stuart Campbell . . . . .	31
6.7 Macroplant remains, by Patrice Vandorpe . . . . .	32
6.8 Glass, by Jill Turnbull . . . . .	34
<b>7 The Significance of the Excavations</b> . . . . .	<b>35</b>
<b>8 Archiving</b> . . . . .	<b>37</b>
<b>9 Acknowledgements</b> . . . . .	<b>38</b>
<b>10 References</b> . . . . .	<b>39</b>

---

## LIST OF ILLUSTRATIONS

---

1	Location of the excavation sites . . . . .	2
2	Holyrood Road: the extent of soil truncation . . . . .	4
3	Holyrood Road: the sequence of burgh boundaries . . . . .	5
4	Holyrood Road: section A–B through ditches [100] & [106] . . . . .	5
5	Holyrood Road: ditches [100] & [106] from the west . . . . .	6
6	Holyrood Road: Phase 3 . . . . .	7
7	Holyrood Road: wall [090] from the east . . . . .	8
8	Holyrood Road: a) Phase 4 (17th century); b) Phase 5 (late 18th/19th century) . . . . .	10
9	Holyrood Road: well A from the west . . . . .	11
10	Calton Road: a) Phase 1 (14th–15th century); b) Phase 2 (15th–16th century); c) Phase 3 (17th century); d) Phase 4 (18th century). . . . .	13
11	Scottish Post-Medieval Oxidised Ware (SPMOW) . . . . .	16
12	Scottish White Gritty Ware (SWGW) . . . . .	17
13	Imported pottery types . . . . .	18
14	Scarborough Ware . . . . .	21
15	17th-century Anglo-Netherland imports . . . . .	21
16	Hafner Encrusted Ware. Shard E (Calton Road) . . . . .	21
17	Billon penny of Robert III . . . . .	21
18	Pipe bowls: nos 1–3 pre c 1640 and Dutch Type bowls. Nos 4–11 William Banks . . . . .	22
19	Pipe bowls: nos 12–17 Thomas Banks. Nos 18–20 John Banks . . . . .	23
20	Pipe bowls: nos 21–26 William Young. Nos 27–32 Patrick Crawford. . . . .	24
21	Pipe bowls: nos 33–36 Patrick Crawford. Nos 37–38 RS. No. 39 WR. No. 40 David Banks. Nos 41–42 WI. No. 43 IA. Nos 44–45 c 1700 pipes. . . . .	25

---

## LIST OF TABLES

---

1	Holyrood Road: radiocarbon dates from ditch [100] . . . . .	7
2	Holyrood Road: ceramics by phase . . . . .	15
3	Calton Road: ceramics by phase. . . . .	16
4	Holyrood Road: animal bone NISP . . . . .	27
5	Holyrood Road: macroplant content of selected contexts. . . . .	33



---

# 1 ABSTRACT

---

The following paper presents the results of two excavations undertaken in 1999 and 2000 within parts of the World Heritage Site of the Old Town of Edinburgh and the Canongate. Excavation at Plot N of the Holyrood North Re-Development Project, Holyrood Road, unearthed evidence of Medieval boundary works (including a possible 12th-century

burgh ditch), a 17th-century well, a Medieval grain-drying kiln, refuse pits, drainage features and Post-Medieval cultivation soils. Excavation alongside Calton Road revealed evidence of Medieval/Post-Medieval property divisions, cultivation soils and quarry pits. Both sites yielded significant artefact assemblages.

---

## 2 INTRODUCTION

---

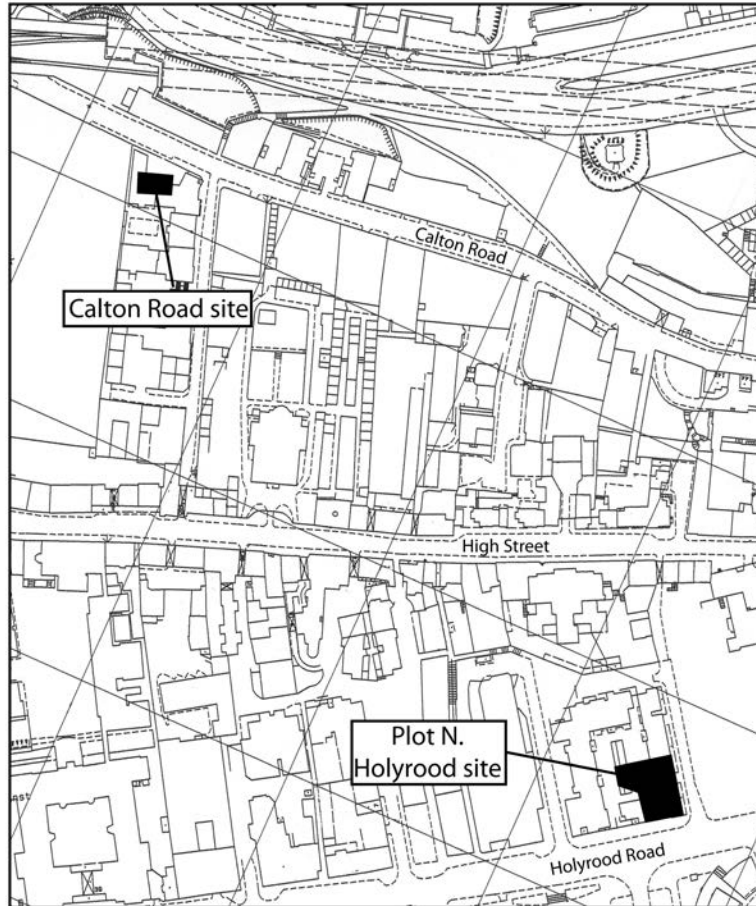

*Illus 1 Location of the excavation sites*

Prior to residential developments, AOC Archaeology Group undertook archaeological excavations in 1999 and 2000 at two locations within the Canongate, Edinburgh (illus 1). Lying between Arthur's Seat and Calton Hill, the Canongate is situated on the lower part of the crag and tail feature created by the glacial obstruction of the Castle Rock. The main street is situated along the east to west ridge of the

tail with perpendicular slopes running down to the original limits of the burgh on the lines now occupied by Calton Road, to the north, and Holyrood Road, to the south. Both excavations were located in peripheral zones of Medieval/Post-Medieval backland activity. The excavations therefore presented an opportunity for a comparative examination of development on either side of the Canongate.



---

## 3 HISTORICAL BACKGROUND

---

The Medieval burgh of Canongate has its origins in charters (1128 × 1153) granted to the Augustinian Abbey of Holyrood by David I, allowing the right to establish and enclose (*herbergate quoddam burgum*) a burgh between the Abbey and Edinburgh (Pryde 1965, 37; Barrow 1999, 122–125). In the 12th century only one other religious house, Arbroath, was granted the foundation of an associated burgh (Dennison 2005, 5). The rank of regality, giving the power of criminal jurisdiction in Abbey lands to the Abbey, was conferred in 1343 (RCAHMS 1951, liii). Despite Canongate being erected into a burgh of regality in 1587, its longstanding rivalry with Edinburgh ended with the purchase of superiority by Edinburgh in 1636 (Pryde 1965, 60).

The burgh possessed the same boundaries from its formation until its incorporation with Edinburgh. Domestic structures would have fronted a main road extending from Edinburgh's Netherbow Port to Holyrood. 'Backlands', literally the thin strips of land to the rear of the measured burgage plots' frontage houses or workshops, stretched northwards to the North Back of the Canongate (now Calton Road) and southwards to the South Back of the Canongate (now Holyrood Road). Its 'herring bone' morphology was therefore typical of that of many other Scottish burghs such as Elgin, Forres, Haddington, Linlithgow and Montrose (Coleman 2004, 283).

There is little historical documentation relating to the early burgh. The absence of a strong defensive wall rendered the largely timber buildings of the Medieval period vulnerable to burning by marauding English armies, as well as to the assaults of various factions involved in Scotland's 16th-century civil wars (MacKay 1879, 18).

Nevertheless, the burgh enjoyed substantial benefits from the proximity of the Court. Periodic episodes of royal accommodation at Holyrood Abbey had led, by the 15th century, to the building of discrete secularised apartments, and this royal association with the Abbey ultimately led to James IV's plan (1501) for Holyrood Palace, situated next

to the monastic cloister (Gallagher 1998). By the 16th century, overcrowding in Edinburgh was juxtaposed with fine private residences lining the main Canongate thoroughfare or 'calsy', first paved in 1535 (Grant 1882, ii, 3). Many of these would have been the homes of the nobility, officials and retainers of the royal court recently established at Holyrood Palace.

Despite the court moving to London in 1603 and protestations of the resultant poverty, many master craftsmen still resided in the Canongate in the mid 17th century (Wood 1956, 10–16, 34). Even in the late 18th century, members of the nobility still had homes in the Canongate. Nevertheless, the 'braw flittings' (the upper classes moving home) noted by Chambers (1996, 296) only served to illustrate the burgh's accelerating 18th-century decline deriving from the cumulative effects of the move of Parliament to London (Simpson et al 1981, 49); the opening of new routes into Edinburgh (Bonar 1856, 21; Withrington & Grant 1975, ii, 7) and the migration of the upper classes to the fashionable New Town.

Early cartographic evidence shows buildings beginning to spread very gradually into the backlands from the Canongate frontage in the late 17th century; many of these structures were probably timber-built. A century later, in 1799, a warrant submitted to the Dean of Guild Court to erect a stone-built, three-storey tenement in Old Tolbooth Wynd required the demolition of an old tenement 'which was built with lath and plaster'. This was one of four warrants submitted for building consent in Old Tolbooth Wynd between 1771 and the turn of the century (McDougall petition dated 26th April 1799, *Edinburgh Dean of Guild Court Warrants 1762–1863*). Nonetheless, it was not until the 19th century that building in the backlands really took hold. Eventually, late 18th- and 19th-century industrialisation resulted in much of the Canongate backlands becoming a mix of tenemented slums and factories (Simpson et al 1981, 49).

---

## 4 HOLYROOD DEVELOPMENT NORTH SITE, PLOT N, HOLYROOD ROAD

---

### 4.1 Location

The excavation was located on the northern side of Holyrood Road and to the west of Reid's Close, Canongate, Edinburgh (NGR: NT 2665 7377) at 36.1m OD. Other than the adjacent 17th-century 'Haddington House' to the west, early cartographic evidence shows the immediate area of the trench to have remained free of any buildings until the late 18th century. By the mid 19th century, a brass foundry occupied the northern part of the site, while a brewery was established on the site by the end of the 1890s.

### 4.2 Earlier archaeological investigations

In 1991 an archaeological evaluation was undertaken on the site of the former Holyrood Brewery. Part of this assessment encompassed the Holyrood

Road site. One trench found three soil horizons, containing heavily abraded pottery. The pottery from the earliest soil was entirely of White Gritty Ware dating from the 13th century to the 15th century (CECAS 1991, 4).

The excavation of the site for the Parliament building, lying to the immediate east of the present site, revealed five broad phases of Medieval and Post-Medieval activity. An important early feature was a large ditch over 3m wide and 2m deep in the south of the site, running parallel to Holyrood Road. Later Medieval features included Medieval street frontages, property boundaries and typical backland features replaced by 16th- and 17th-century cultivation slots and the remains of formal gardens (HAPT 2008).

### 4.3 Excavation results

The Plot N excavation area covered approxi-

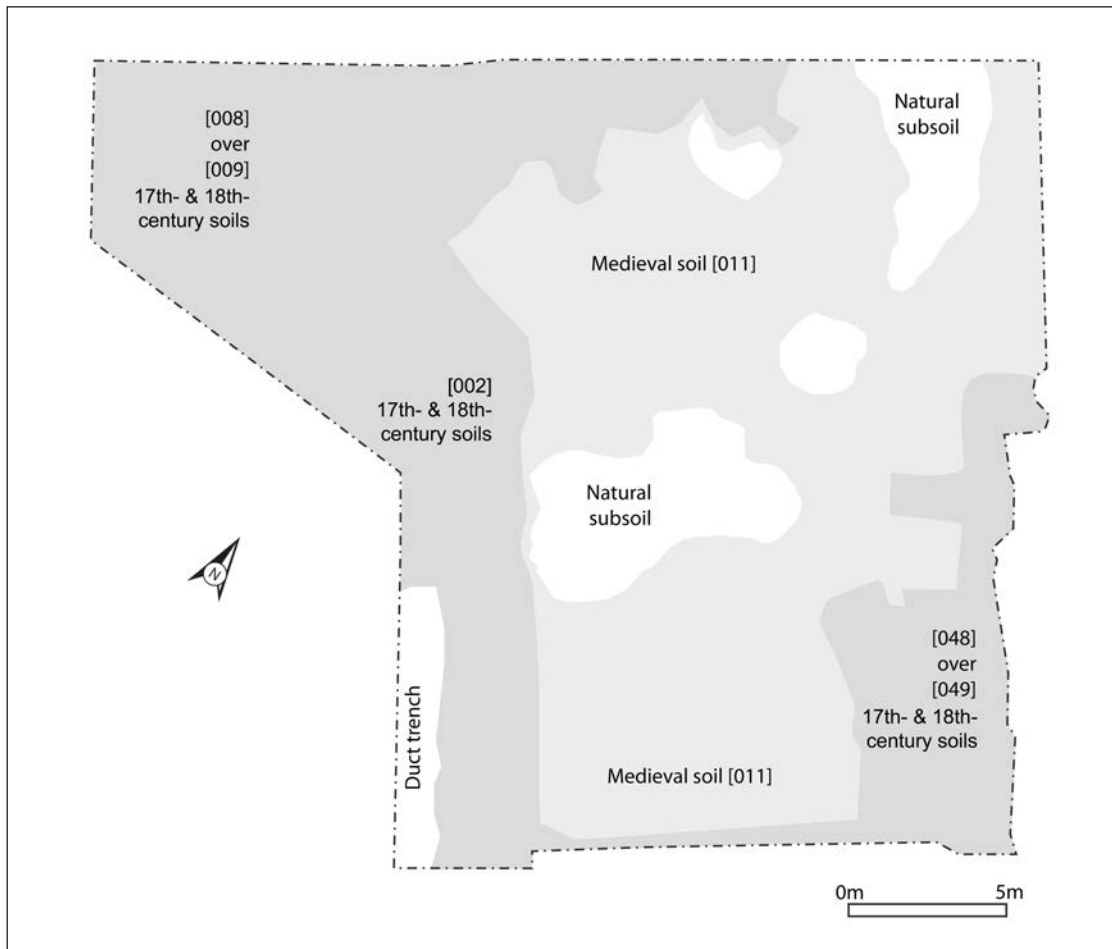

Illus 2 Holyrood Road: the extent of soil truncation

mately 600m<sup>2</sup> and was covered by up to 1.3m of demolition debris from a 19th/20th-century brewery building. Its removal revealed a massive intrusion which reached the glacial till at a depth of approximately 3m in places and truncated the greater part of the soil profile in the central part of the site. There remained areas of *in situ* soil layers in the western and south-eastern parts of the site (illus 2). Five broad phases of activity were identified.

#### 4.3.1 Phase 1

Till was met at approximately 34m OD. Residual 12th-century ceramic shards were present in a number of later contexts.

#### 4.3.2 Phase 2a: large boundary ditch (possibly 12th century)

Given the findings on the Parliament site (HAPT 2008) the continuation of a substantial ditch feature had been anticipated. A ditch feature was recognised in section during the removal of a duct which ran below Holyrood Road. Variation in sub-surface strata had also been observed when excavating overlying features. Orientated east to west along the southern part of the excavation area, ditch [100] had inwardly sloping sides to a flat base at an average depth of 1.25m. Width varied from an average of 2.6m on the surface, narrowing to roughly 1.7m at the base (illus 3, 4 & 5). The ditch could represent either the early enclosure of the grounds of Holyrood Abbey (the precinct limits of early religious institutions

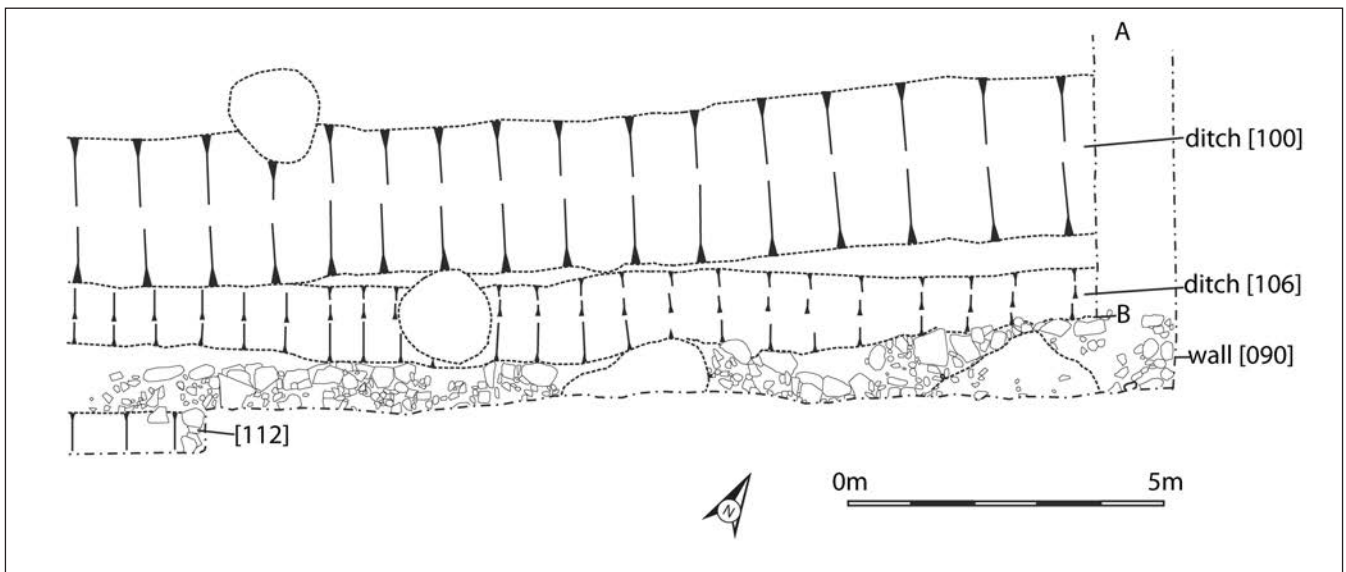

Illus 3 Holyrood Road: the sequence of burgh boundaries

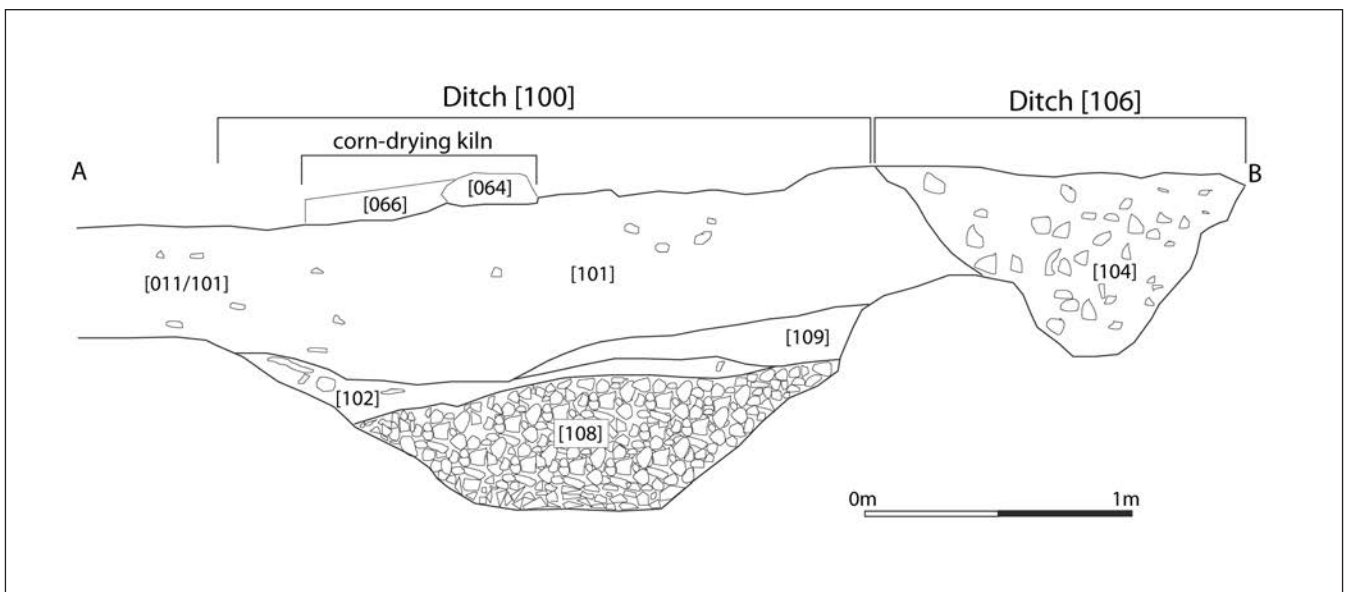

Illus 4 Holyrood Road: section A-B through ditches [100] & [106]



*Illus 5 Holyrood Road: ditches [100] & [106] from the west*

could be quite extensive – Yeoman 1995, 19) or the enclosure of the burgh referred to in its 12th-century charter. As the alignment of later boundary features (see wall [090] below) fossilised the course of this ditch until the 16th century, when the burgh was well established, the identification of this feature with the burgh ditch is credible.

#### 4.3.3 Phase 2b: backfilling of ditch [100] (13th century)

Ditch [100] was filled by the following sequence of deposits: the upper ditch fill [101] was interpreted as a slumped continuation of the principal Medieval soil [011]. This was underlain by intermittent deposits of yellow clay, which in turn overlay dumped sand and stone deposits. The basal ditch fill comprised approximately 80% stones in a thin matrix of mid-brown silty soil [105]. As the overlying clay deposits were usually little more than lenses of material tilting down to the north, these perhaps denote a period of erosion of the southern edge of the ditch after the deposition of stones at its base but before infilling was completed. The stones were angular to sub-rounded and varied in size along the length of the ditch, with occasional voids and varying degrees of compaction. At the eastern end, the basal fill [108] became entirely clast supported, with no discernible matrix (illus 4). It appears that,

as the ditch became redundant, it was deliberately back-filled with stones dumped at its base. In dating the back-filling event, ceramic evidence (Haggarty below) provided a tight 13th-century assemblage from the basal fills [105] and [108] of the ditch.

Three samples of animal bone from ditch fills [105] and [108] underwent dating by accelerator mass spectrometry (Table 1). The radiocarbon dates were calibrated using the University of Washington Quaternary Isotope Laboratory Radiocarbon Dating program, Rev. 4.0 1998. AA-44591 encompassed the late 11th to early 13th centuries, while AA-44593 ranged between the later 12th and mid 13th centuries (both at 1 sigma ( $\sigma$ ) level). AA-44592 is interpreted as providing a rogue date due to taphonomic movement through the upper slumped fill [101] of the ditch.

#### 4.3.4 Phase 2c: small boundary ditch (13th/14th century)

A smaller ditch feature [106], lying slightly to the south, paralleled the course of the earlier ditch [100] and was cut into Medieval soil [011] (illus 3, 4 & 5). In places the ditch profile's northern edge sloped more gradually than the southern edge, becoming a stepped side, especially in the east. The average depth was roughly 0.7m with a surface width of 1.3m, narrowing to 0.4m at the base. Its fill was a

**Table 1 Holyrood Road: radiocarbon dates from ditch [100]**

Lab code	Sample material	Context	Yrs BP	$\delta^{13}C$	Calibrated dates	
					1 sigma	2 sigma
AA-44591 (GU-9516)	Bone: cattle femur	Fill [105]	870 ± 40	-22.4‰	AD 1070–1219	AD 1036–1261
AA-44592 (GU-9517)	Bone: cattle radius	Fill [108]	575 ± 40	-21.8‰	AD 1318–1412	AD 1299–1430
AA-44593 (GU-9518)	Bone: cattle metapodial	Fill [108]	850 ± 40	-22.5‰	AD 1161–1242	AD 1042–1276

mid-brown silty sand. The feature is interpreted as a foundation trench for a timber palisade, which may have been contemporary with some of the Phase 3 domestic features.

#### 4.3.5 Phase 3: 14th–16th century

Underlying the upper soil horizons was a weakly acid to neutral humic mineral soil [011]. This Medieval

soil horizon appears to have been less disturbed by cultivation and manuring than the Post-Medieval Phase 4 and 5 soils (see below), although a high phosphate content suggests the incorporation of material such as bone, faeces and urine. Soil [011] was cut by features representing several discrete episodes of activity.

Evidence of backland division was limited to a 0.6m wide stone-filled drain [029] which emerged from the northern section and ran towards the south for a

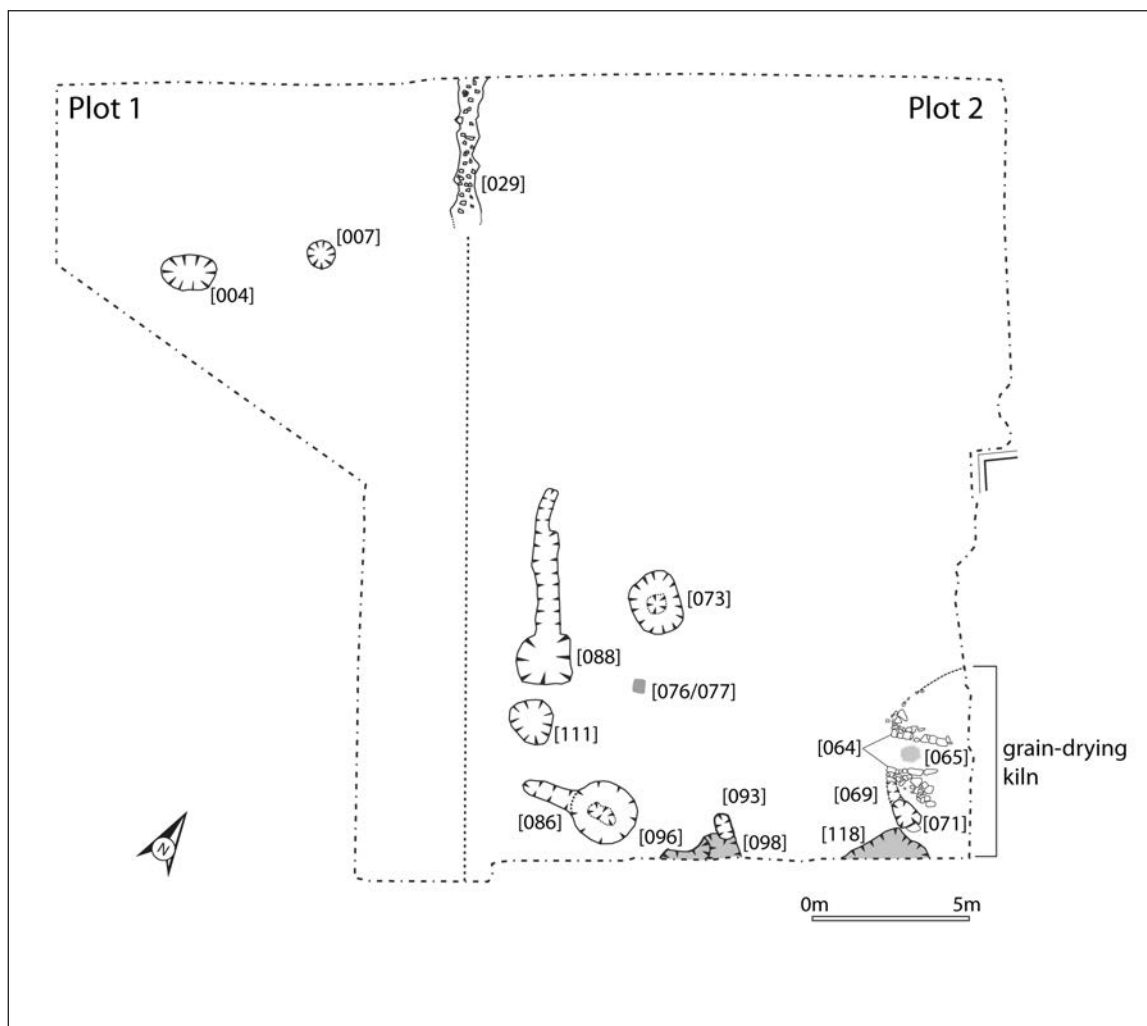

*Illus 6 Holyrood Road: Phase 3*



*Illus 7 Holyrood Road: wall [090] from the east*

distance of approximately 4m before fading (illus 6). To the south, a linear gully on the same alignment, but slightly to the east, extended northwards from square pit [088]. Approximately 6.25m long, the cut maintained a width of roughly 0.7m over most of this distance, with a maximum depth of 0.55m. The minimum width of Plot 1, to the west, was 13.5m, with Plot 2 being at least 17.5m wide. Only two features, 14th-century refuse pits [004] and [007] were recorded within Plot 1, although excavation in this area did not extend to the end of the plot.

Plot 2, to the east, contained several large pits and a grain-drying kiln (illus 6). The vestigial remains of this feature post-dated both boundary features [100] and [106] and pre-dated an early 16th-century burgh wall [090] (see below). Two lines of stonework [064] survived to a maximum of two courses in height. These stone lines had opposing dressed faces, formed of flat, sub-rectangular stones, forming an entrance or passage into an area defined by soil change and intermittent stonework. The passage narrowed to the east and a discrete charred, organic-rich, deposit [065] lay between the stone lines. An arc of mildly compacted dark grey/brown clayey silt with black mottling, contained within a shallow hollow

[069], defined the southern extent of the feature and resulted from this part of the structure being robbed out. The hollow was truncated by a 16th-century post-hole [071]. A compact, heat-affected, orange/yellow clayey silt [066] was contained by the northern edge of the feature. The location of a grain-drying kiln on the periphery of the plot probably reflects a common precautionary strategy in attempting to minimise any spread of accidental fire.

Pit [086] was 2m in diameter. In profile, its sides sloped inwards to a flat base at a depth of 0.8m. An extension, probably the trench for a flue, located at a level above the base of the pit, continued westwards for a distance of 1.7m. The U-shaped profile of this arm measured 0.6m in width, with an average depth of 0.3m, and terminated in a butt end. Filled with a homogeneous silty sand [087], its structured keyhole shape indicates some form of heat-related processing activity. Perhaps robbed of internal stone furnishings, it may have been the groundwork for an oven or kiln. To the north lay a small scoop [077], measuring 0.46m × 0.4m × 0.06m deep and filled with burnt soil [076] which was rich in slag. Refuse pit [111] also lay immediately adjacent, to the north.

A large pit [073] occupied a central location. Sub-rectangular in plan, it measured 2m by 1.6m with a U-shaped profile to a step at a depth of 0.8m. A small, centrally located, sub-rectangular hollow was cut to an additional depth of 0.2m. The uppermost [072] and basal [079] of the pit's three fills included clayey deposits surviving along the pit's sides. Assuming these deposits represent the remnants of a clay membrane or lining, either a storage or processing function for the pit can be inferred.

After the grain-drying kiln went out of use, wall [090] was built over the area of its southern arc (illus 3 and 7). The wall was aligned east to west along the southern limit of the site, parallel to Holyrood Road, and survived to a maximum height of 0.5m. Approximately 0.9m wide, the wall comprised up to two courses of undressed facing stones with rubble infill.

In a small southern extension to the excavation area, wall [090] was found to overlies a break of slope, with Medieval soil [011] being confined to the north of the wall (illus 3). A short stretch of crude walling [112] ran to the south of wall [090]. At a maximum of two courses in height (0.4m) and with a width of 0.38m, its northern end appeared to overhang the larger wall. This, and the truncation of the wall by refuse pits, illustrates that backland activity continued to the south beyond the excavation area.

Wall [090] probably represents the remains of a wall referred to by Mackay (1879, 16), built to enclose the Canongate in 1513. The scale of the wall implies that it was never intended as a serious defence against a concerted assault, despite its alleged construction date being contemporary with the battle of Flodden. An enemy attacking Edinburgh generally forced access by the Water-Yett (Water Gate), took possession of the Canongate, and then attempted

the assault on Edinburgh through the Netherbow Port (ibid, 16–17).

If wall [090] is the 1513 wall, it was apparently short-lived. The ‘English spy’s plan’ (Cowan & Inglis 1919, pl A) of Hereford’s attack on Edinburgh in 1544 shows parts of the northern burgh wall as missing, either having been slighted by the English or fallen into a state of disrepair. The excavation found that wall [090], interpreted as the corresponding southern burgh wall, was truncated by three inter-cutting refuse pits [093], [096] and [098], which yielded either late 15th- or 16th-century ceramics, indicating that the southern burgh wall may also have been ruinous at the time of the 1544 attack.

The three rubbish pits [093], [096] and [098] were centrally situated on the southern edge of the site (illus 6). The pits were of varying sizes and only one pit was fully exposed; [096] had also suffered from truncation from above by cesspit [085/094]. The fills were particularly rich in marine shell (oyster), animal bone and charcoal, with pit [098] containing a Robert III (1390–1403) silver billon (see Holmes below). A further refuse pit [118], containing residual 14th-century pottery, truncated wall [090] in the south-east.

#### 4.3.6 Phase 4: 17th century

This phase saw the deposition and subsequent use for cultivation of various mechanically sorted soils [002 lower], [009] and [049] (illus 2).

The cultivation soils [002] and [009] fall into the category of anthropic humic mineral to organic soils (Avery 1980). The high organic content, neutral pH and high phosphate content of the soil is likely to be a product of heavy manuring, as evidenced by the finds assemblage. A lack of calcium carbonate indicates relative rarity of oyster shell and other marine shell and that the shell present had not been well mixed into the soil matrix. In the southern, eastern and western portions of the site soil [049] has been equated to the upper part of soil [002]; this too was anthropic humic soil that was subjected to heavy manuring.

The last agricultural or horticultural use of these soils is represented by a series of ten closely spaced linear cultivation slots, aligned east to west, entering the south-eastern part of the excavation area (illus 8a). Hand dug, all shared a similar profile, although there was some variation in dimensions. Width varied from 0.62m to 1.5m (average 0.97m) while depth ranged from 0.17m to 0.41m (average 0.23m). There was some disparity in the nature of the fills, although most were found to contain crushed mortar particles and oyster shell. Finds provide a date range encompassing the second half of the 17th century. Similar 17th-century cultivation slots have been recorded at Market Street (Hall 1997a, 28) and Cinema House, St Andrews (Ross & Clark 1997, 25) and Forfar (Spearman 1982).

Gordon’s map (1647) shows the Canongate

backlands, including the excavation area, as fine formal gardens in the mid 17th century. These slots illustrate that a change to small cultivation plots evident on the north side of the Canongate in the *Prospect of Edinburgh* (c 1690), also occurred on the southern side.

A rubble-built property boundary wall [003], approximately 0.75m wide, and aligned roughly north to south, traversed the north-western part of the site. The mortar pointing contained oyster pinnings, which were especially prevalent on the eastern side. Its four to five courses survived to a height of 0.76m and separated Post-Medieval manured garden soils to the east and west. No foundation cut was observed. This wall appears as a property boundary represented on Gordon’s (1647) map.

Well A was probably constructed and back-filled during the 17th century (illus 8a and 9). A clay capping of re-deposited sub-soil [019] overlay the stonework of the well and the rubble fill of the well’s construction pit. This served a mechanical function in capping the construction pit rubble and consolidating the stonework lining. This stone lining was a drystone build of undressed, angular blocks with supporting wedges. Roughly circular in plan, with an internal diameter of approximately 1m, the well narrowed towards the base at a depth of 2.05m. The construction pit was roughly circular in plan and U-shaped in profile, narrowing towards the base from a maximum diameter of 3m. The stone fill of the construction pit was angular rubble; this formed an integral component of the well’s technology, as it permitted water seepage into the construction pit, which subsequently acted as a reservoir. Once redundant, the well was back-filled with a loose black organic clayey loam. A small shallow scoop [025] measuring 0.95m by 0.56m by 0.2m deep lay immediately to the south of the well.

An oval drystone-built structure [089], probably a cesspit, was found in the extreme south of the site. A few handmade bricks attributable to the 17th century (N. Crowley pers comm) were incorporated within this structure. It survived to three or four courses, 0.3m high, and was laid over a stone floor. Internally it measured 0.8m by 0.75m.

Pit [018], measuring 5m by 2m by 0.5m deep, was filled by dumps of loose angular stones and was interpreted as a sump. Although it underlay soil [049], pottery finds suggest that it was probably dug through this horizon with its cut obscured by later cultivation.

#### 4.3.7 Phase 5: 18th/19th century

This phase consisted of mechanically sorted humic soil layers [002 upper], [008] and [048] demonstrating that the excavation area was under cultivation in the late 17th and 18th centuries (illus 3).

The neutral humic soil [008], lying to the west of wall [003], had a lower organic content than its

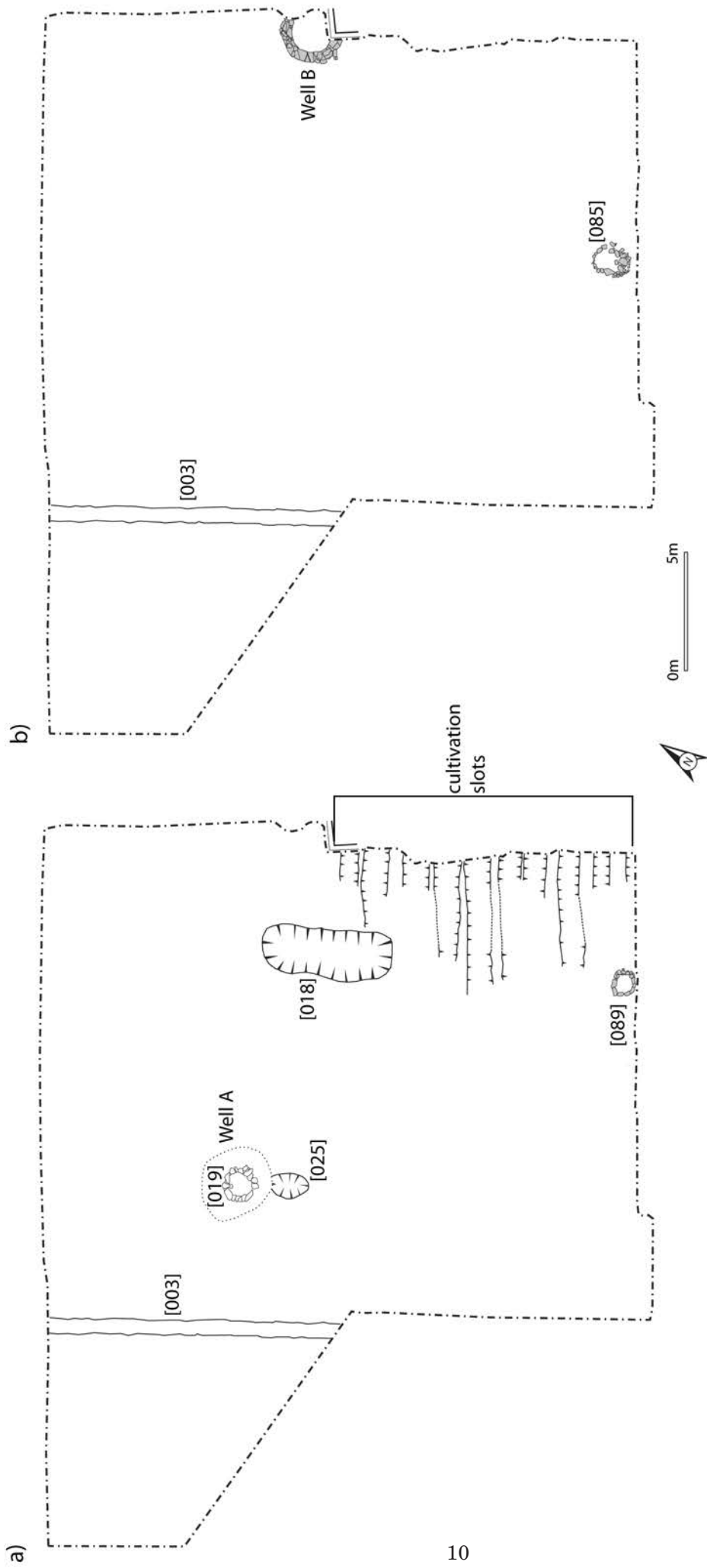

*Illus 8 Holyrood Road: a) Phase 4 (17th century); b) Phase 5 (late 18th / 19th century)*





*Illus 9 Holyrood Road: well A from the west*

equivalent soil [002 upper], situated to the east, indicating a less intensive manuring regime. The uppermost soil [048] in the southern part of the site, which overlay the 17th-century cultivation slots, was slightly more organic than that of the underlying horizon [049], probably reflecting the surface application of manure.

An early 19th-century oval cess-pit [085], with edging stones set around its rim, lay near the southern trench edge. Well B, a stone-built well infilled with builder's rubble, probably in the 19th century, lay in the eastern/central part of the site.

---

## 5 CALTON ROAD

---

### 5.1 Location

Located near the Medieval boundary of the North Back, this excavation presented another opportunity to investigate activities in the peripheral backlands zone in a situation that was a near mirror image to that of the Holyrood Road excavation. The excavation was located immediately to the south of Calton Road and to the west of Old Tolbooth Wynd, Canongate, Edinburgh (NGR: NT 2635 7381) at 42.5m OD.

The Canongate Charity Workhouse, founded in 1761 (MacKay 1879, 133), lay on the opposite side of Old Tolbooth Wynd adjoining the graveyard of Canongate Parish Church (built 1688–91) (RCAHMS 1951, 153–6, no. 89). The North Back was a route favoured by royalty in travelling from Holyrood Palace to the City. An Act by James VI called for it to be rendered and maintained as a thoroughfare suitable for royal passage (MacKay 1879, 115–116). Gordon's 1647 map shows a rectangular building adjoining the Old Tolbooth Wynd gate and fronting the North Back to the north-east of the excavation area. The excavation area may have encompassed, or lain directly to the west of, a backland associated with 167–169 Canongate, a rubble-built tenement of three storeys and an attic, pre-dating 1647 (RCAHMS 1951, 174, no. 106).

Early cartographic evidence shows the immediate area of the excavation trench to have remained free of any buildings until the 19th century; the burn running along the North Back is no longer present on maps after 1780. During the early 19th century the area was open ground, probably gardens, associated with the Magdalene Asylum (NSA 1845, 158). By the mid 19th century, Canongate Foundry had been established to the east, while to the west Edinburgh Gas Works was established in 1817. The Gas Works' continued expansion throughout the 19th century resulted in its coal shed covering the excavation area. Continuity of use by this industry was maintained until recently, with the area being occupied by a Scottish Gas office and storage premises.

### 5.2 Earlier archaeological investigations

Following the discovery of human remains near Calton Road in January 1997, an evaluation investigated two areas immediately adjacent to the Calton Road site. On the northern side of Calton Road only features related to buildings of post-1750 date were unearthed. To the east, two walls of the Canongate Poorhouse (established *c* 1760) were located, their foundation trenches cutting a series of accumu-

lated deposits of manured garden or cultivation soils dating from the 12th century onwards (CECAS 1997,14). The Canongate Tolbooth, built in 1591 (RCAHMS 1951, 173–74, no.105), stands at the head of the Old Tolbooth Wynd. Excavation of its cellar revealed superimposed floor levels and cut features with finds including Post-Medieval green-glazed pottery and clay pipe fragments (Holmes 1988).

In October 2000, an evaluation was carried out on the Calton Road site. Trenching of a 0.4ha land parcel found the southern two-thirds of the proposed residential development area to be completely truncated to drift or solid geology by 19th- and 20th-century development. The two northernmost trenches contained buried soils, up to 2m thick, containing Medieval ceramic shards and mammal bone, below 2–2.5m of 19th/20th-century building debris (Gooder 2000).

### 5.3 Excavation results

The excavation was carried out in November 2000. It consisted of a single trench measuring 17m × 7m with its long axis aligned east to west (illus 10). The major physical features unearthed were four soil horizons analogous to the 'garden soils' found at a number of Medieval urban excavations such as in St Andrews (Coleman 2004, 303). Soil chemistry analysis showed all to be naturally mildly acidic, with no artificial liming having occurred. The organic content and phosphate levels of the soils were relatively high, typical of garden soils. The uppermost soil layers [202], [203] and [232] had been exposed to more intensive vegetation growth and had midden material added. The presence of shell, animal bone and mortar also explained the high calcium carbonate level throughout the deposits generally. The excavation revealed five broad phases of activity within parts of two burgrave plots.

#### 5.3.1 Phase 1: 14th–15th centuries

No plot division was apparent within this first phase of activity (illus 10a). The basal soil layer [247] was composed of saturated, grey/brown sandy clay with only rare stone, oyster shell and charcoal fleck inclusions. It was cut by two pit features [248] and [250]. Pit [248] was irregular in plan, with maximum recorded measurements of 1.7m by 3.5m. As it extended beyond the trench sections, its full dimensions remain unknown. The profile, as far as could be observed, was of inwardly sloping sides to a maximum depth of 0.65m. It cut the clay

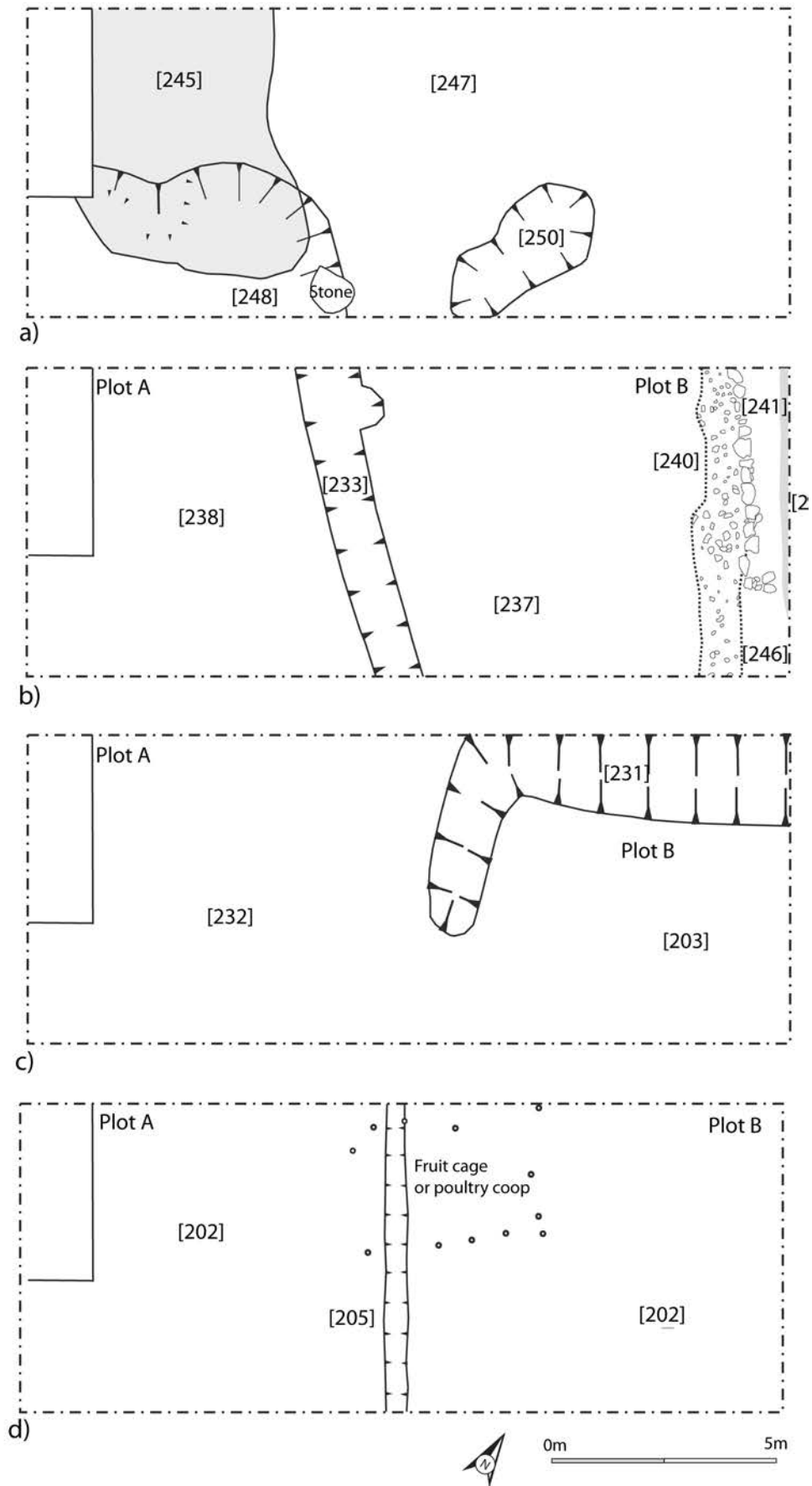

*Illus 10 Calton Road: a) Phase 1 (14th–15th century); b) Phase 2 (15th–16th century); c) Phase 3 (17th century); d) Phase 4 (18th century)*

subsoil, which was rising in the south-western part of the trench. Pit [250] was also irregular in plan, measuring 3.6m by 1.7m with a maximum depth of 0.39m. Both of these features are interpreted as quarry pits.

A surface [245], composed of a thin layer (0.05–0.08m thick) of angular gravel in a pink clayey matrix, was laid over the northern edge of quarry pit [248] once it had been backfilled. It perhaps formed a floor surface or yard for specialist craft activities.

### 5.3.2 Phase 2: 15th–16th centuries

Land division is first apparent during this phase (illus 10b). Plot B was defined by a small ditch/drain [233] in the west and a stony path [240/241] in the east, lying on either side of brown clayey sand soil [237]. Both boundary features were aligned broadly north-west to south-east albeit with some suggestion, given the limited extent of the excavation area, of convergence to the south. The path was approximately 1m wide and up to 0.15m thick, with ceramic shards and animal bone pressed into its surface of small angular and rounded stones [240]. A single line of undressed, angular stones [241] created a crude revetment on its eastern edge. Immediately to the east, gravel deposit [242] extended a short distance into the trench from the eastern section. With a maximum thickness of 0.18m, it represents a hardened surface, possibly a yard, in the adjoining plot. Ditch/drain [233] measured 1.2m wide by 0.4m deep, and defined the limits of two soils [237] (Plot B) and [238] (Plot A). The composition of its fill [234] was similar to that of overlying soil [232].

### 5.3.3 Phase 3: 17th century

Garden soil [203] was an organic silty sand similar to the overlying garden soil [202] but lighter in colour. It occupied the eastern half of the trench, broadly Plot B, to the east of a robbed-out wall trench [205], which had been cut from above (illus 10c and d). An analogous garden soil [232] in the western part of the trench contained occasional deposits of rubble and mortar. Ditch [231] occupied the north-eastern quadrant of the trench. Aligned east to west along

the northern trench section after emerging from the eastern section, the feature then turned south at its western end where the ditch base rose; the feature terminated in mid trench. Its maximum dimensions were 1.9m wide by 0.78m deep. Its upper fill was a speckled, dirty pink mixed clayey deposit, overlying a primary fill of a very dark brown/black gritty matrix with gravel, coal and charcoal inclusions. A boundary function can be ascribed to this feature, an interpretation supported by the relatively higher organic content of its lower fill. As a boundary ditch it would be expected to fill with detritus from plots to either side. Significantly, whereas its north to south component follows the approximate course of the earlier and later boundaries between Plots A and B, its abrupt turn to the east indicates some change in land division through the sub-division of Plot B across its north–south axis and by enlargement beyond its former eastern boundary. In the mid 17th century Gordon’s map (1647) shows large, elaborate formal gardens extending to the North and South Backs. It could therefore date to either the earlier or later 17th century.

### 5.3.4 Phase 4: 18th century

The uppermost garden soil [202] was a manured, dark-brown/black, slightly clayey soil with occasional oyster and rare mussel shell. Robbed-out wall trench [205] re-established the 15th/16th-century plot boundary (illus 10d). It was cut by one of 13 timber stakes (average diameter 0.1m) forming a roughly rectilinear arrangement (3.8m by 2.5m). The stakes were of unsquared pine (*Pinus* sp.) with their sharpened points driven into the ground. Given the documented history of the site, it seems plausible to ascribe a horticultural function, possibly a fruit cage, or a structure such as a poultry coop.

### 5.3.5 Phase 5 (19th/20th centuries)

Up to 2.5m of 19th- and 20th-century building rubble covered the entire area of the trench. A dump of several thousand stoneware bottle shards (from the Caledonian Pottery, Glasgow c 1825–50) was encountered in the trench’s eastern section.

## 6 POST-EXCAVATION ANALYSES

The following specialist reports are edited versions. The full texts, drawings and appendices will be lodged as part of the project archive with the National Monuments Record of Scotland.

### 6.1 Ceramic material, by George Haggarty

#### 6.1.1 Scottish Post-Medieval Oxidised Ware (SPMOW) and Scottish Post-Medieval Reduced Ware (SPMRW)

The vast bulk of the pottery recovered from the upper levels of the Holyrood Road and Calton Road sites were shards of Scottish Post-Medieval Oxidised Ware (SPMOW) and its reduced version (SPMRW) (Tables 2 and 3).

Typically in the late 15th and early 16th-centuries, gritty fabrics began to disappear and Scottish potters, for reasons not yet fully understood, began to produce pottery much smoother to the touch. This change may have been the result of cultural factors, but it was just as likely due to the introduction of new technology, such as larger kilns and new clay sources. One possible change in clay source would have been the use of thick estuarine clay beds exposed after large-

scale peat extraction from the carse lands. These excellent iron-rich clays fire red under oxidising conditions and dark grey under reduction.

Both SPMOW and SPMRW have a ubiquitous distribution within Scotland, and a long date range. Evidence now suggests that the industry started some time in the late 15th and continued, at least in the Forth littoral, into the third quarter of the 18th century. This revised and surprisingly late date comes from an assemblage of pottery excavated at Wester Steading, Dalmeny (Haggarty 2004). There appears to have been a production site for this type of pottery in 17th-century Glasgow, around the Old Calton area (Haggarty 1980, 37 & Quail 1982, 1–3) and in the vicinity of Stirling Castle (Haggarty 1980, 37). More recent archaeological findings have subsequently proven both propositions to be correct (Caldwell & Dean 1992, 2–7).

Fully reduced SPMRW shards recovered from both excavations appear to be almost exclusively from large jugs, dating from the 17th century, which generally had multiple wavy grooving on the shoulder and were covered with thick dark olive-green lead glaze. Oxidised shards of SPMOW are normally from a range of much smaller jugs, skillets, flanged bowls, drug pots, etc (Haggarty 1980, 11–22).

**Table 2 Holyrood Road: ceramics by phase**

Ceramic type/Phase	Unstrat	6	5	4	3	2c	2b	Totals
19th century	9	30		1				40
18th century	4	6		2				12
17th-century tin glaze			1	14				15
Late Medieval Red Ware				4				4
Late Medieval Reduced Ware				6				6
PMRW 16th century			12					12
SPMRW	8	2	23	161	6			200
SPMOW	12	14	24	336	9			395
SWGW	2	5	70	261	766	35	13	1152
Gritty red fabric 15th century				4				4
Yorkshire Type Ware				2	41	1		44
Humber Type Ware					2			2
Scarborough Type Ware					3			3
Other English			1	3	4			8
Continental imports		7	10	29	6			52
Others		2	5	13	4	2		26
Pantiles			1	4				5
<b>Totals</b>	<b>35</b>	<b>66</b>	<b>147</b>	<b>840</b>	<b>841</b>	<b>38</b>	<b>13</b>	<b>1980</b>

**Table 3 Calton Road: ceramics by phase**

Ceramic type/Phase	5	4	3	2	1	Totals
19th-century Stoneware bottles	37					37
18th century		65				65
17th century		1	3			4
17th-century Red Ware			1			1
Late Medieval Red Ware		1				1
SPMRW		56	61	6	3	126
SPMOW		164	130	28	1	323
SWGW		13	6	23	154	196
Yorkshire Type Ware					5	5
Scarborough Type Ware			1			1
Continental imports		8	26	3		37
Others		6	2		1	9
Pantiles		5				5
<b>Totals</b>	<b>37</b>	<b>319</b>	<b>230</b>	<b>60</b>	<b>164</b>	<b>810</b>

These forms are often extremely hard to identify from body shards alone. It is worth noting that a great number of the oxidised shards have reduced light grey cores or patches of grey on the surface. There appears to have been no deliberate attempt to reduce the pottery; therefore it can still be classed as SPMOW. Often the oxidised shards are covered with a thin red coating. This can be called a random glaze effect, as it is almost certainly caused in the kiln by the iron in the clay body being drawn out then re-deposited back onto the surface.

Recent analysis (Chenery, Phillips & Haggarty 2004, 45–53; Haggarty, Hall & Chenery 2011) suggests that the Scottish Post-Medieval pottery industry is more complicated than hitherto believed and that there are many more Scottish production sites using iron-rich clays still awaiting discovery.

Documentary evidence of ceramic production in

the Edinburgh area has revealed that at least seven potters were working just outside the city wall, in the area of Potterrow, in the first half of the 17th century. Thus it seems likely that most of the iron-rich SPMOW and SPMRW pottery from both the excavations was locally produced. Dates attributed to the bulk of this material are based on excavated ceramic groups published from the City of Edinburgh and the wider Forth littoral (e.g. Holmes 1975; 1986; Haggarty & Alexander 1998; Haggarty 1980a). It was, however, the important excavations at Throsk which have contributed most to our understanding of the later chronology of this industry (Caldwell & Dean 1992, 1–46). Previously SPMOW single-handled, internally-glazed vessels have been called chamber pots, a term which suggests a very specific function. The term single-handled jar is suggested as an alternative.

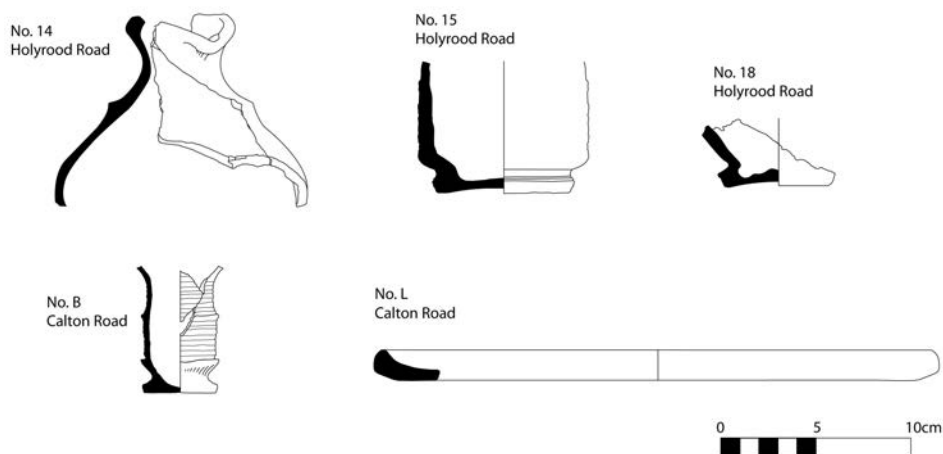

*Illus 11 Scottish Post-Medieval Oxidised Ware (SPMOW)*

This report has used the resources available to illustrate those SPMOW forms not usually encountered (illus 11). These include a platter (shard L) and small albarello style drug jar (shard B) from Calton Road [232] (Phase 3). From Holyrood Road [002] (Phase 4), there is a unique bottle (shard 14), a larger drug jar (shard 15), and from pit fill [084] (Phase 6), a small frilled base, probably from a jug copying German stoneware (shard 18).

### 6.1.2 Scottish White Gritty Ware (SWGW)

The vast majority of the Medieval pottery from both sites derives from the Scottish White Gritty Ware tradition (SWGW); a ceramic industry which has been discussed at some length (Haggarty 1984; Cox 1984; Crowdy 1986; Hall 1997a). It may be possible to identify three distinctive production areas along the Scottish east coast: Tweeddale, the Lothians and

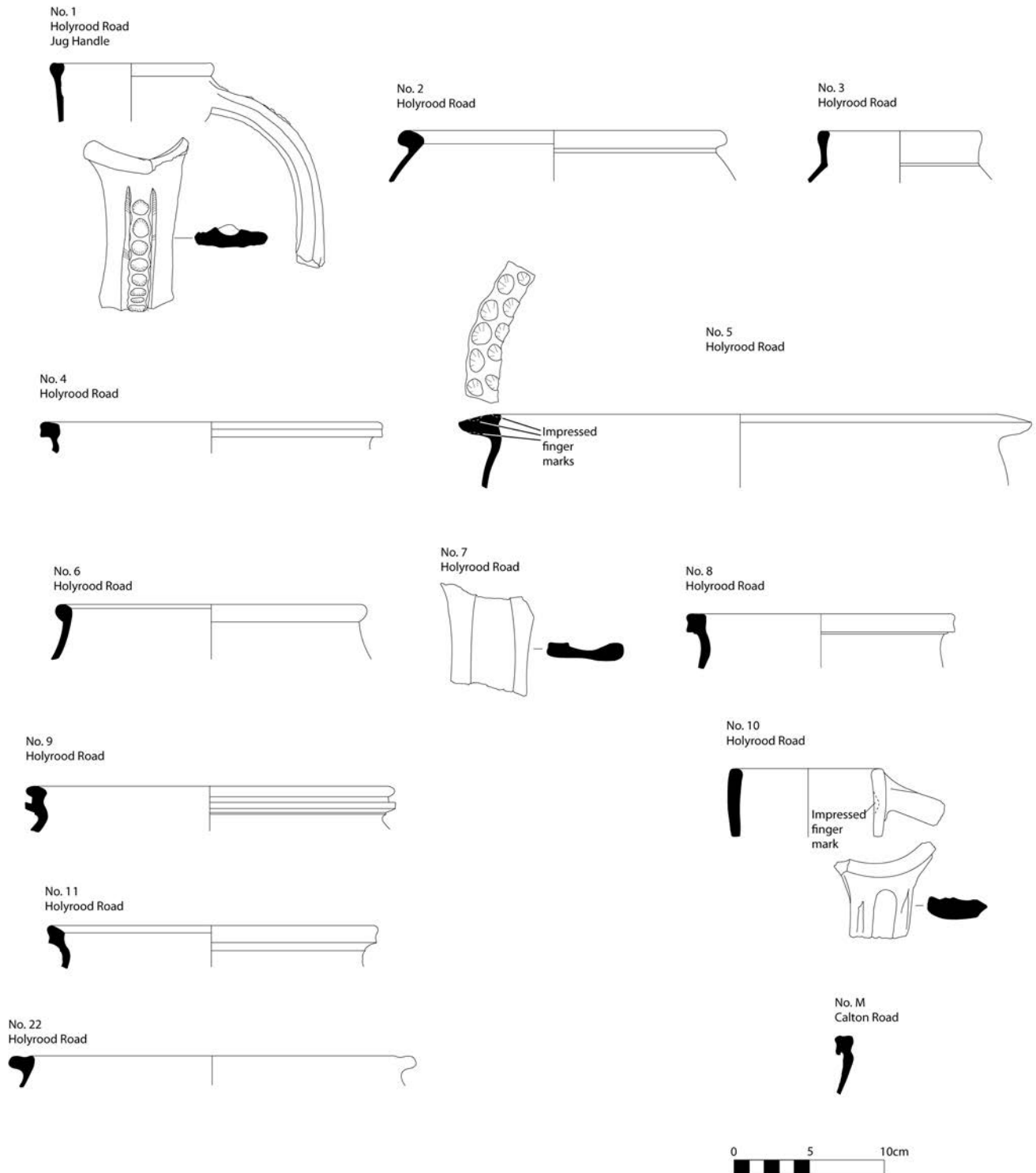

Illus 12 Scottish White Gritty Ware (SWGW)

No. 12  
Holyrood Road

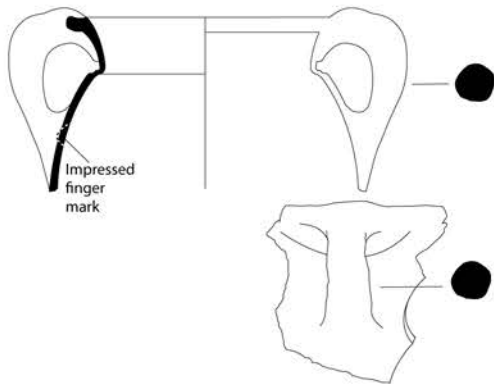

No. 13  
Holyrood Road



No. 20  
Holyrood Road



No. 19  
Holyrood Road



No. G  
Calton Road



No. D  
Calton Road

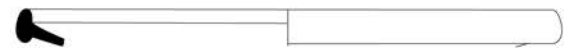

No. J  
Calton Road



No. F  
Calton Road



No. A  
Calton Road

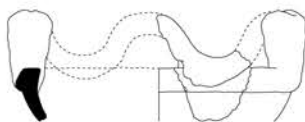

No. I  
Calton Road

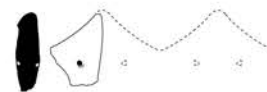

No. 16  
Holyrood Road

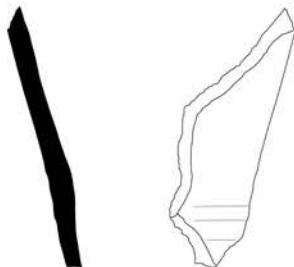

No. K  
Calton Road



*Illus 13 Imported pottery types*



Fife (Haggarty 1984 and Haggarty & Will 1996). The hypothesis for a Border industry was based, in part, on the pioneering mineralogical work on the pottery from Kelso Abbey (Cox 1984). The evidence for production in the Lothians comes from the excavations and survey work carried out at the multi-phase kiln site at Colstoun, near Haddington (Brooks 1980), while from Fife there is a suggestion that some distorted ceramic material recovered during First World War trenching of a midden at Tentsmuir, just north of St Andrews, was possible wasters (Laing 1973). Subsequent publications of large stratified groups of Medieval pottery from St Andrews (Haggarty & Will 1996; Hall 1997a) has increased our knowledge and confirmed a large sub-group of SWGW vessels with two-handles and evidence for fuming, suggesting that they had been used as cooking pots.

Recent chemical analysis on a number of SWGW shards of probable 13th-century date from another site in the Canongate (Jones et al 2006), suggests that the SWGW recovered in Edinburgh, the Canongate and Leith at this period was obtained from different sources, signifying that, like the later Red Ware industry, there are many Scottish Medieval White Ware kiln sites still awaiting discovery. Recent work at Ceres by Martin (1987) and at Coaltown of Wemyss by AOC Archaeology (Goeder 2007), backs this up with evidence of two new White Ware production sites. It is believed that the introduction of monasticism into Scotland in the 12th century brought large-scale production of wheel-thrown pottery into Scotland (Haggarty 1984). The majority of the SWGW shards reported on here are fragmentary and in no case was it possible to piece together enough to create a profile. Therefore the material illustrated can do little more than show a range of rim forms (illus 12, shards 1–11, 22 & M).

### 6.1.3 A summary of the imported wares

By far the most common Continental imported pottery from the two sites is Dutch Post-Medieval Lead-Glazed Red Earthenware, of which there are almost 40 shards. This pottery was manufactured in many centres and it is almost impossible to suggest a kiln source. Shards are generally hard to date, as the types have a wide date range. The shards from Holyrood Road come mainly from soil layers [002], [048], [049] which seem to be broadly 17th-century in date. This is in keeping with the shards [232] recovered from Calton Road. Where we can identify the form, the shards are from vessels used in cooking, i.e. skillets or cauldrons (illus 13 – shard 12); this is borne out by the presence of soot on the exterior surfaces. The hard red fabric is tempered with fine sand and, in the main, has an orange to orangey-brown thick, glossy glaze on the interior and often on the upper half of the exterior.

From the 22 shards of 17th-century Cologne/Frechen stonewares from the sites, only two, which conjoin, have evidence of their typical stamped

mask and medallion decoration, Holyrood Road Well A backfill [020] (illus 13 – shard 13). Another ceramic import from Germany represented on the sites comprises the seven earthenware shards from hammer-headed Weser slipware dishes. These were all recovered from 17th-century contexts – Holyrood Road cultivation slot fill [045] (illus 13 – shards 19 and 20) and Calton Road soil horizon [232] (illus 13 – shards G, D and J).

From Germany, in the Medieval period, there are three shards of Langerwehe Stoneware, Holyrood Road [009] and [011] (Phase 3) and Calton Road [237] (Phase 2), plus two shards of Siegburg, Holyrood Road soil horizon [011] (Phase 3) and Calton Road soil horizon [246] (Phase 2). This is in stark contrast to the very large and important German stoneware assemblage recovered from an earlier excavation carried out on the Edinburgh High Street (Clark 1976). Also from Germany, and indicative of high status, is a small fragment of a 16th-century stove tile, Calton Road soil horizon [232] (Phase 3) (illus 13 – shard F). This is one of six such fragments recently identified from Scotland (Haggarty & Hall 2010 67–74). Continental and British stove tiles have been retrieved from 35 known find spots in the UK, of which 25 were in the Greater London area (Gaimster et al 1990). The distribution of stove tiles in England showed a pattern of high-status ecclesiastical (pre-Dissolution) and aristocratic use. Continental lead glazed stove tiles were also traded around the Rhine and Low Countries but to date only a few production sites are known (Gaimster 1988; Gaimster et al 1990). Also from northern Europe is a residual shard of Andenne Type Ware from the Meuse Valley retrieved from context [049] Holyrood Road. This shard has a buff-white fabric covered in an orange-yellow, external glaze. Borremans and Warginaire (1966) dated the main phase of production of this early pottery industry to between the 11th and mid 15th centuries. The limited evidence available from Scottish sites suggests that it is only the glazed sagging-based jugs/pitchers which are represented, and which date from the 12th to early 13th centuries.

There are nine shards of French imported pottery from the two sites. These include, from Holyrood Road [002/TP16], a shard from a Martincamp Type II brown stoneware flask of 16th-century date, and from Holyrood Road [049/TP38] (Phase 4) a small body shard from an early Saintonge polychrome decorated jug. The Saintonge area has long been known for its Medieval pottery industry, which developed in the late 11th or early 12th centuries, producing a range in fine white to buff fabrics, often micaceous. The range was exported in vast quantities from the mid 13th century (Chapelot 1972). The most distinctive of the early Saintonge products are the glazed, polychrome decorated jugs, which usually occur in contexts of the late 13th or early 14th centuries.

From Calton Road context [232] there are two shards of late Saintonge plain, a shard from a 16th-

century Beauvais green-glazed earthenware mug and a shard from a Loire narrow-necked jug. Also recovered from [238/TP4] (Phase 2) was a green-glazed rim shard from a common late 16th-century Type I Saintonge chafing dish (Hurst 1974, 233). On this shard the face mask is missing, but it retains a small hole which was used, before firing, to fix the mask to the dish with a small wooden pin (illus 13 – shard I). Soil layer [203] also provided two abraded shards from another Saintonge chafing dish of a rare form (illus 13 – shard A). This Hurst Type C.VIII, which has arcaded knobs applied as a continuous strip, has been dated to the mid 16th century, based on an almost complete excavated example from Grimsby Lane, Hull (Watkins 1993, 106 fig. 74, 261). If this date is correct the Calton Road example must be residual, as the context cannot be earlier than the 17th century. Recently shards from two other similar chafing dishes have been recovered from excavations in Scotland, Ayr and Leith, making the total for Britain six, the other two coming from Plymouth (Clark 1979, 30; Haggarty 2006, Word file 14).

Spain is represented by a large shard (illus 13 – shard 16) from a Seville olive jar of a type notoriously difficult to date (Goggin 1960, 25). The shard was recovered from Holyrood Road (fill [084] of cess pit [085/094]), which is dated to the 19th century. This late date for the import of Spanish coarsewares into Scotland is backed up by the discovery of a large group of at least 17 examples of what are perceived to be Iberian flat-based storage vessels and covers in Leith dating to *c* 1815 (Haggarty & Lawson work in progress).

A small rim shard from Calton Road soil [232] which comes from a high-status, north Italian marbled polychrome bowl, probably Pisan, is by far the most important shard of imported pottery from the two excavations (illus 13 – shard K). The fabric is smooth, hard and brick-red and both surfaces have been decorated with white, green and brown joggled slip under a lead glaze. The resulting marbled effect has for the most part flaked off the exterior. Italian pottery is extremely rare in Scotland, with this being the first find spot for this class of pottery, although at least 50 examples are known from England (Hurst et al 1986).

The English imports of the Medieval period are, by and large, from the Yorkshire area, and were mainly recovered from the Holyrood Road site, with one of six Scarborough Type Ware shards coming from the upper fill [101] of ditch [100] (Phase 2b) (illus 14 – shard 23). The only Scarborough shard of any note from the Calton Road site came from soil [232] and was residual (illus 14 – shard H). There are a number of shards of Yorkshire Type Wares from Holyrood Road soil [011] (Phase 3) and also from fill [104] of ditch [106] (Phase 2c) (illus 14 – shard 21). There was also a shard of Humber Type Ware, recovered from pit [004] (Phase 3).

The Holyrood Road evidence from the Scottish SWGW and the Yorkshire imported pottery suggests soil [011] dates to the 14th-century date,

and the backfilling of ditch [100] (Phase 2b) to the 13th-century date, while residual shards from the basal fill [113] of pit [098] date to the end of the 12th century.

There are almost 50 shards of Tin-Glazed Earthenware (TGE) from the two sites, of which the majority are of 18th-century date and in the form of small abraded fragments. Only two Anglo-Netherlands fragments of 17th-century date have been illustrated (illus 15). One recovered from cess-pit [084] on the Holyrood Road site is covered in a very distinctive pink-tinged tin glaze (illus 15 – shard 17). The second, from a similar drug jar with the same pinkish colouring, comes from Calton Road soil [232] (illus 15 – shard C). It is customary to class these wares as Anglo-Netherlands, as the area of production cannot be identified with any certainty. However, the documentary evidence suggests that most TGE coming into Scotland through Leith at this period was mainly from the Low Countries.

From Calton Road soil [232] there is a body shard from an open vessel in a thin red sandy fabric, which looks Dutch. It is covered on both surfaces in a thick lead glaze and has sticking to its exterior a thin applied pad of clay, adhering to which is a coating of fine stone chippings (illus 16). There is a class of pottery from Germany called Hafner Encrusted, which uses this form of decoration to cover areas of the body. The technique was used on both red and white firing clays and was widespread (Grohne 1940). It was copied in England in the 17th century, which makes it difficult to identify the source of individual shards. If this fragment is Hafner, then it is only the second find in Scotland; it is of interest that the first find was also from the Canongate, at the Parliament site (Cox & Hall 2008, 83 fig. 87). There is, however, another possibility, and that is that the encrusted pad became attached during firing when the glaze ran. The use of quartz grits (in the middle of the 18th century) as a method to prevent kiln furniture from sticking to pottery during firing is known from both Staffordshire (David Barker pers comm) and the Prestonpans area of Scotland, where the author recovered examples from a trench being excavated by workmen. The date of introduction of this technique is uncertain; the Calton Road shard dates, however, from the 17th century.

Calton Road context [232] produced a large number of imported shards, including the shard from an Italian bowl; Frechen Stonewares; Weser Slipware; Hafner style and shards from the French regions of the Loire, Beauvais and Saintonge. Also recovered were shards of Dutch Red Wares and TGE, including tiles, drug pots and chargers. Although most of this material was extremely fragmentary, it is suggestive of an area of high-status occupation.

## 6.2 *Coin, by Nicholas N McQ Holmes*

A billon penny of Robert III minted in Edinburgh during the period 1390–*c* 1403 was recovered from

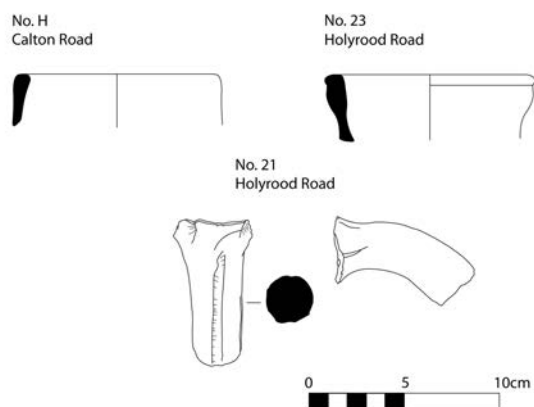

*Illus 14 Scarborough Ware*

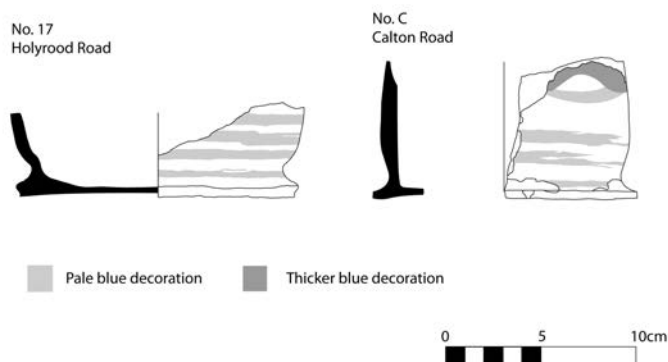

*Illus 15 17th-century Anglo-Netherland imports*

a 16th-century refuse pit [098] from the Holyrood Road site. The coin possibly shares the same obverse die as the example held in the NMS collection, but the reverse die appears to be unrecorded (illus 17).

### 6.3 Clay tobacco pipes, by Dennis B. Gallagher

The pipes from the Holyrood Road and Calton Road excavations are a substantial addition to the corpus of Edinburgh pipes of the 17th century and in themselves represent a microcosm of the Edinburgh pipe industry in the 17th century. In addition, they provide invaluable dating evidence for the contexts from which they were retrieved. Examples of the assemblage, showing in particular form and markings, are depicted in illus 18–21.

The assemblage includes a few examples of pipes produced outside Edinburgh. Dutch pipes, although common elsewhere in Scotland during the 17th century, are relatively rare in Edinburgh, where the local industry was vigorous (Davey 1992, 283).

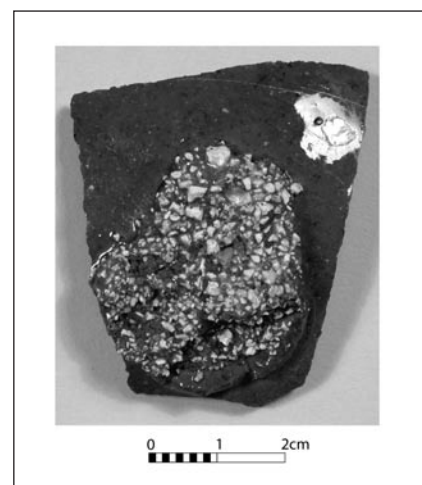

*Illus 16 Hafner Encrusted Ware. Shard E (Calton Road)*



*Illus 17 Billon penny of Robert III*

No. 3, a bowl with a crown and moulded, is a low-quality Dutch pipe but is the first recorded example in Scotland of a design produced in a number of centres in the Netherlands, for example in Leiden (Duco 1981, 244 and 453); Amsterdam (de Haan & Krook 1988, 36); Gorinchem (van der Meulen et al 1992, 101) and Nijmegen (Engelen 1988, 138–9). Finds from Holyrood Road [027] included a stem decorated with a 'ring of pearls' roller stamp design of probable Dutch origin. There are also a small number of English pipes, including London Type 14 and 15, from Calton Road [202] & [223] (Atkinson & Oswald 1969, 178) and a Tyneside Type bowl of Edwards (1988, 10), type 9, dated to 1680–1720 (Holyrood Road, [002]; not illustrated). The small number of Tyneside bowls found in Scotland suggests that most were carried as personal possessions.

The imported pipes comprise a very small minority in comparison with the native Edinburgh pipes. These start chronologically with the pipes of William Banks, the first pipemaker active in Edinburgh, where he held a monopoly in pipe-

Pre c.1640 bowls and Dutch type bowls

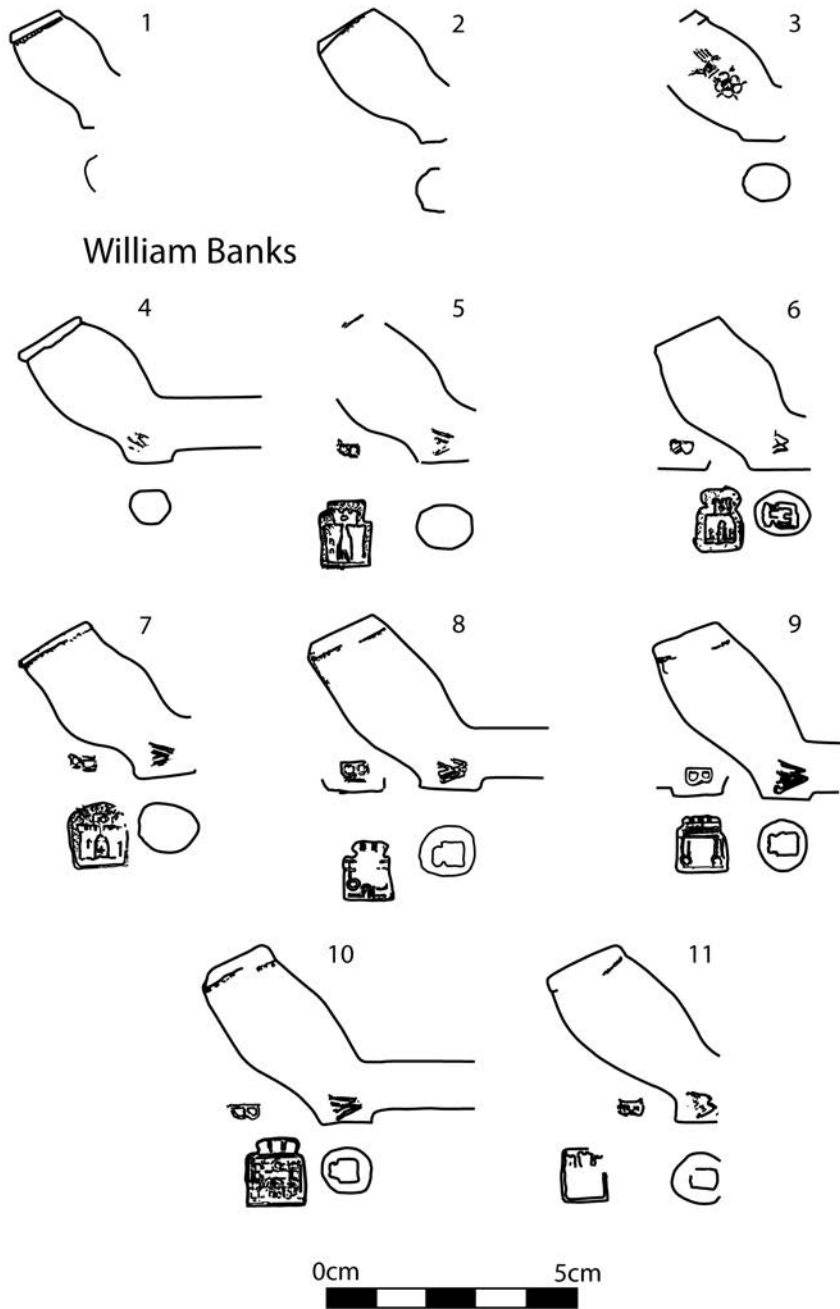

*Illus 18 Pipe bowls: nos 1–3 pre c 1640 and Dutch Type bowls; nos 4–11 William Banks*

making from the early 1620s (Gallagher 1987b, 6). Finds of pipes from this early period are uncommon in Edinburgh, suggesting that smoking was not a widespread habit until the mid 17th century. No. 1 dates from the early 17th century, although it is not known if it is an Edinburgh product. Bowls 2 and 3 are similar to bowls from a pre-1637 context at the

Tron Kirk, Edinburgh (Gallagher 1987a, 269–70). These bowls are without maker's marks, as is usual with early pipes from Edinburgh, apparently due to William Banks' monopoly on pipe manufacturing at this time. In the 1640s William Banks introduced a system of marking pipes that differed from that used elsewhere. The sides of the base were

## Thomas Banks

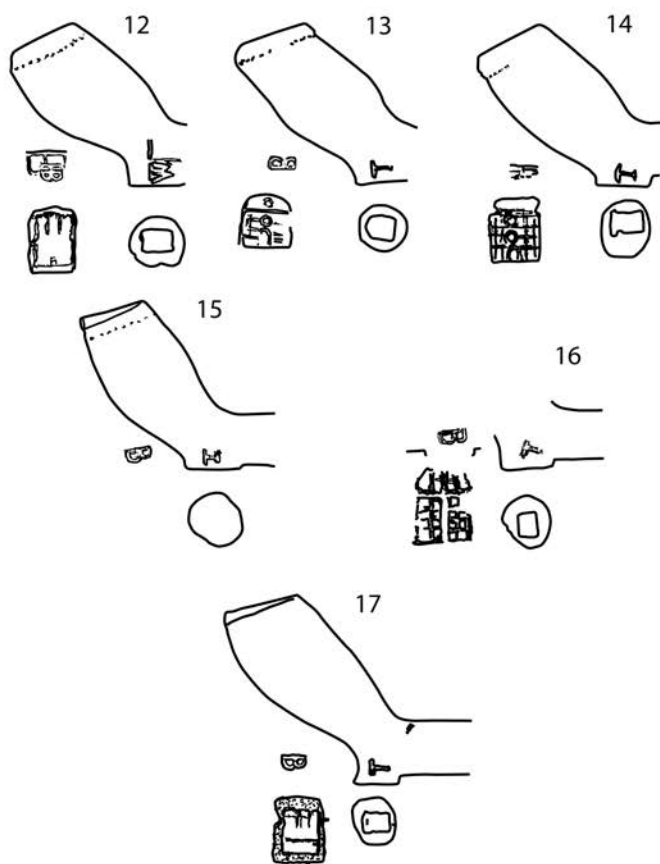

## John Banks

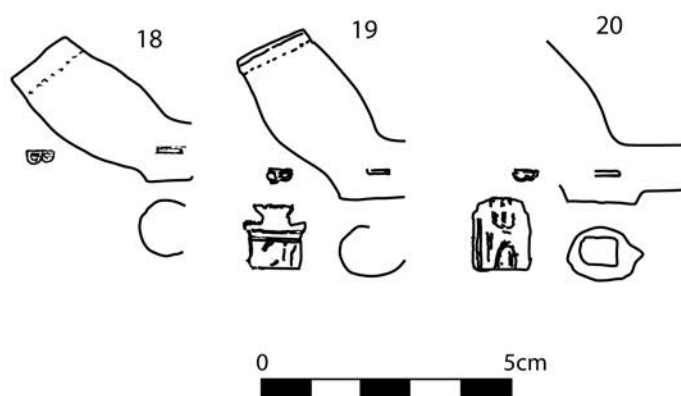

*Illus 19 Pipe bowls: nos 12–17 Thomas Banks; nos 18–20 John Banks*

marked in the mould with his initials, WB, and high-quality pipes were stamped with the symbol of Edinburgh, copying the type of hallmarks used by contemporary goldsmiths and pewterers. This system continued to be used throughout the 17th century by almost all Edinburgh pipemakers. The present group contains five bowls from Holyrood

Road and twenty bowls from Calton Road that have been identifiable as products of William Banks. All are from the later years of his career, c 1640–60 (nos 4–11). The pipes vary considerably, ranging from biconical bowls to taller, straight-sided forms. Three bowls from Calton Road [202], including no. 4, are earlier examples of c 1640–50. They

## William Young

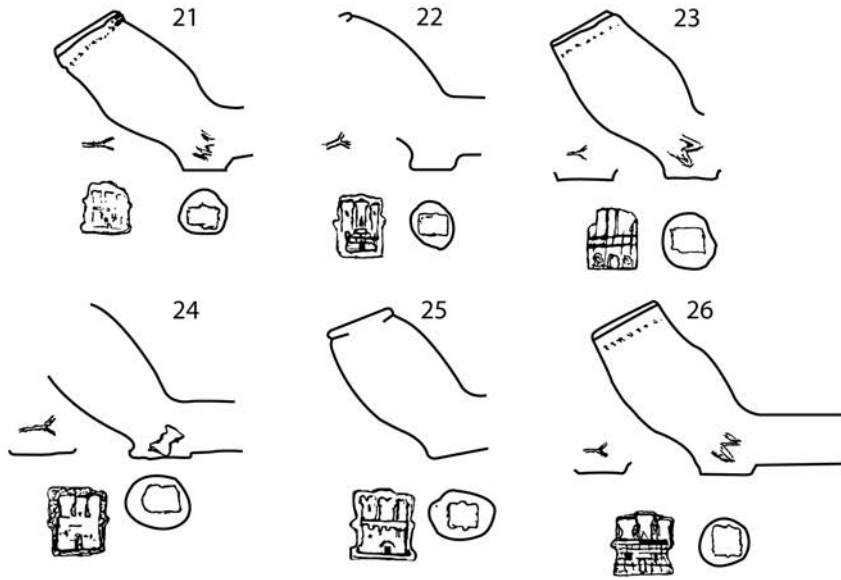

## Patrick Crawford

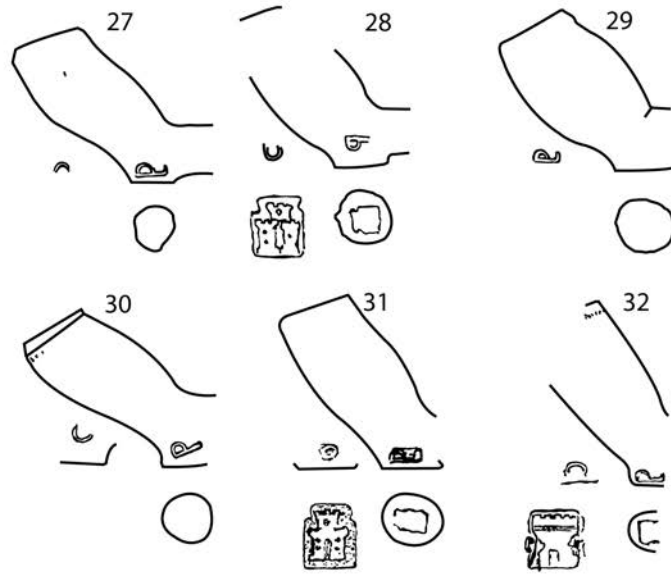

*Illus 20 Pipe bowls: nos 21–26 William Young; nos 27–32 Patrick Crawford*

are poor-quality products, the rims grooved with heavy-handed bottering (shaping to give a rounded profile), with the faint maker's marks partly obscured by the careless finishing. In contrast is a bowl from Calton Road [232], a late form highly finished in red clay. No. 11 is a more elegant narrow-necked bowl, possibly influenced by English West Country forms, either directly or through London,

e.g. London Type 17 (Atkinson & Oswald 1969, 178), and usually dated to post-1660.

William Banks was succeeded after his death in 1659 by his son, Thomas. No. 12 is a pipe from a mould where the WB has been altered to TB. It is possible that pipes marked WB, obviously well-recognised, continued to be produced by Thomas Banks for some time after the death of his father.

Patrick Crawford

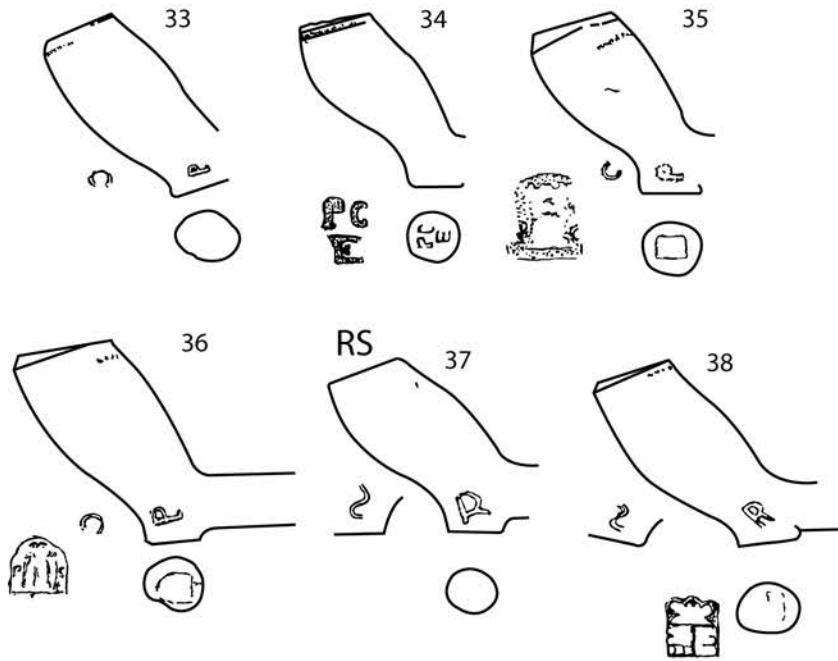

W/R

David Banks

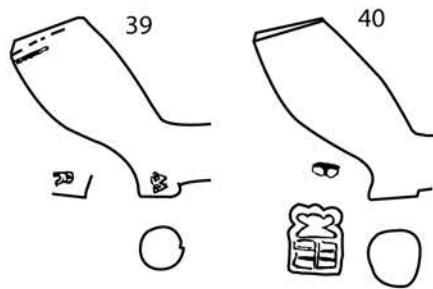

WI

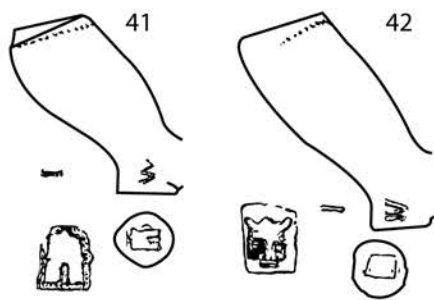

IA

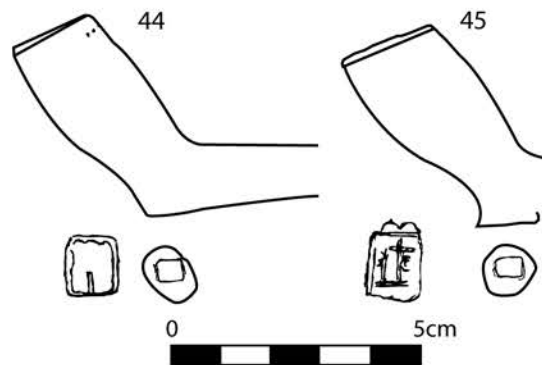
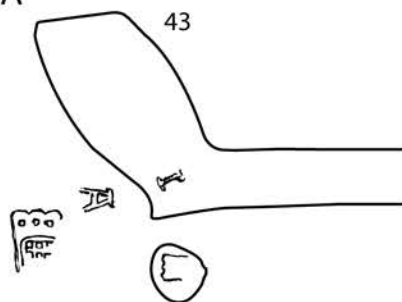

Illus 21 Pipe bowls: nos 33–36 Patrick Crawford; nos 37–38 RS; no. 39 WR; no. 40 David Banks; nos 41–42 WI; no. 43 IA; nos 44–45 c 1700 pipes

No. 13 has a well-curved forward-leaning form that retains elements of the early biconical pipes. Other bowls have developed a form with more parallel sides (no. 15), similar to contemporary London form 18 (Atkinson & Oswald 1969, 178). No. 17 (Holyrood Road [045]) is a large 'chinned' form with an unusually small base, possibly of post-1680 date, possibly influenced by contemporary Bristol forms. Four, and possibly five different basal stamps are found on the TB pipes in the present assemblage.

Nos 18–20 are pipes of John Banks, another son of William Banks. The exact business relationship between the two sons is not known. John Banks is recorded as a pipemaker in 1661 and may have continued later than this. An IB pipe, possibly by this maker, was identified in a 1698–1700 context at Darien (Horton et al 1987, 244, no. 11), which would suggest that he was still active at the end of the century. The JB pipes in this assemblage are dateable to *c* 1660–80.

Pipes marked WY (nos 21–26) are identified as products of William Young, who is recorded as a pipemaker in Edinburgh from 1653 until his death in 1670 (Gallagher 1987b, 9). The typical bowls of this maker are somewhat crude, with lumpy forms (e.g. no. 21), which contrast with elaborate basal stamps. No. 26 is a slimmer, more elongated form, possibly influenced by late forms of London Type 10 (Atkinson & Oswald 1969, 178) which must date to the later years of Young's career. Young employed a variety of stamps which, when not from worn dies, often display remarkable detail, e.g. the carefully delineated ashlar on no. 26.

Patrick Crawford, active *c* 1670–1700, was the most prolific Edinburgh pipemaker of the latter part of the 17th century. The pipes in the illustrated assemblage demonstrate the great variety of forms produced by this maker (nos 27–36). Crawford's workshop was capable of producing a variety both of quality and form to suit special market requirements, as shown by his supply of pipes in 1696 for the fleet sailing to establish the ill-fated colony at Darien (Gallagher 1987c, 234; Horton et al 1987, 243). The illustrated group starts with forward-leaning narrow bowls which still retain elements of the earlier biconical form (nos 27–9). Later forms tend to have straighter sides (no. 31). No. 36 (Calton Road [202]) is an example of a large bowl from the last years of Crawford's output. Similar bowls were recovered from a 1698–1700 context at the Scottish colony of Darien (Horton et al 1987, 243).

The PC pipes have examples of at least three different basal stamps used by Crawford covering a wide variety of design. The stamps on bowls 32, 35 and 36 incorporate the maker's initials, PC, a practice unique in Edinburgh to Crawford. No. 34 is an example of a three-letter basal stamp, a practice used by a limited number of Scottish makers, where the lower letter represents Edinburgh, the place of manufacture.

The RS pipes, nos 37–8, may be identified with Robert Smith, who is documented as a pipemaker in

the early 1680s (Gallagher 1987b, 11). Wide bowls with a pronounced S curve to their front profile (e.g. no. 37) are the commonest form produced by this maker. No. 38, a more elegant form, is atypical.

Bowl (40) is a product of David Banks, grandson of William Banks and son of Thomas Banks. Banks is recorded as a pipemaker between 1698 and 1706, although his active career may have been much longer. Pipes are known where the mould has been changed from TB to DB, presumably following the death of Thomas Banks. This may be the case with bowl no. 40, which may be ascribed on typological grounds to *c* 1660–80. As such, it may represent either a pipe from the early part of David Banks' career or the later use of an inherited mould.

Some pipes bear initials that have not been traced in the documentary sources. The possible identifications of the makers with the initials RW (no. 39) and WI (nos 41–2) are unknown. The identity of the maker of the IA pipe (no. 43) is also uncertain; it may be one of the Aiken family, who were active as pipemakers in both Glasgow and Edinburgh. Although the pipe is burnished, the rim, although damaged, appears to be neither milled nor bottered. Nos 44 and 45 are examples of bowls of *c* 1700 date, with poor impressions of Edinburgh-style basal stamps but without discernible maker's marks, although these are sometimes obliterated by over-finishing. They demonstrate the range of bowl forms at this date.

A highly unusual find from Holyrood Road [050] comprises two stems that have writing, in ink, on them although the letters are difficult to decipher and the whole too incomplete to make any apparent sense. The burnishing of pipes, a technique that involves smoothing the surface of the clay with a tool to give a polished surface, is generally taken to be indicative of higher-quality pipes and therefore a possible indicator of status. For example, a study of the pipes from the Post-Medieval mansion of Norton Priory, Cheshire, found that 8% were burnished, contrasting with the 1% from the nearby village of Norton which were burnished (Davey 1985, 166). However, the percentage of the total production that were burnished is likely to have varied between the various centres of pipemaking. At Holyrood Road 11% (51 fragments) of the total pipes were burnished. The same percentage was recorded at Calton Road. This may be compared with the 15.7% of burnished pipe fragments from a larger assemblage (950 fragments) from the Edinburgh Parliament site. This may reflect the deposition of pipes from a general cross-section of the population at Calton Road and Holyrood Road, as opposed to a slightly more aristocratic environment closer to the Palace of Holyrood.

#### 6.4 *Animal bone, by David Henderson*

Details of the methods used can be found in the site archive. Bone fragments were identified as far



as possible to skeletal element and species. Each fragment was examined in order to ascertain the state of epiphyseal fusion and to identify any taphonomic indicators such as butchery marks or signs of gnawing. Morphological and metrical analysis followed von den Driesch (1976), Boessneck (1969); Hillson (1986) and Payne (1969). Age at death data were taken from Silver (1969); Grant (1982); O'Connor (1988) and Payne (1973).

#### 6.4.1 Holyrood Road

A total of 2,853 items of faunal bone was recovered, of which 1,663 (58.3%) were identified to bone and species level (Table 4). Most derived from five contexts [002], [008], [011], [048] and [049], all large soil horizons which yielded 956 identified items, generally poorly preserved, representing 57.5% of the identified bone. The bone recovered from Phase 3 contexts was better preserved and mostly recovered from fills of negative features; it may therefore represent largely primary deposition. Sheep/goat (732 specimens, 44%) and cattle (738 specimens, 44.4%) made up the overwhelming majority of the identified bone. Almost all the bone in the 'sheep/goat' category derived from sheep (*Ovis aries*), with only two being attributed to goat (*Capra hircus*).

Of the other main domesticated animals, pig and horse were the next most common species identified. Cat and dog are present in small numbers throughout the site.

Domestic fowl dominated the bird assemblage, with a few bones of goose also identified. From the size of the goose bones, it would appear that these derived from larger domestic geese rather than from their wild progenitors, the greylag (*Anser anser*). The two duck bones identified may have come from either domestic ducks or wild mallard. No other bird species were represented.

Red deer (*Cervus elaphus*) and fallow deer (*Dama dama*) bones were recovered. The animals were possibly hunted around Arthur's Seat, as Holyrood Park has long been a Royal Park, probably since the 12th century (Historic Scotland 2008).

Few fish bones were recovered by hand in the trench; the bones of both the heads and the backbones of the larger sea-fish (such as cod and ling) are present, suggesting that whole, fresh fish were consumed. The most consistently present fish bones retrieved from processing the soil samples were herring vertebrae, and small numbers of haddock, saithe and other small gadoid fish. 'Bucklers', the dermal spines of the Thornback ray (*Raja clavata*) were recovered, but their presence is possibly over-represented as they are particularly resistant to destruction by taphonomic factors.

Small mammals and amphibians were only retrieved from the sieved sample retents. Fifteen frog bones were recovered from fill [020] of Well A. Phases 2, 3 and 4 yielded the bones of the water vole (*Arvicola terrestris*). Both species indicate a damp environment. One item of human bone (a shaft fragment of an adult right ulna) was recovered from Medieval soil [011].

Data relating to the culling of animals were sparse, but it appears that the cattle were largely kept for milk and traction in the Medieval period, with traction declining in importance in the Post-Medieval period, when there was a slaughter of (male?) animals before the age of two and a half years, presumably for meat and hides.

Sheep were subject to a different pattern of slaughter; in Medieval times up to half may have been killed for meat once full size had been achieved, with the rest of the flock surviving to produce wool and milk, and to breed. In the Post-Medieval phase, after an initial cull of young lambs, most of the flock survive to full maturity and even old age, probably reflecting the increased importance of wool production.

**Table 4 Holyrood Road: animal bone NISP**

Phase	Cattle	Rib	Sheep/ Goat	Rib	Pig	Horse	Dog	Cat	Rabbit	Red deer	Fallow deer
2	130	53	126	30	31	24	7	2	1	3	2
3	106	30	109	11	5	14	3	1			
4	279	102	340	63	20	6	3	2	3	2	
5	26	12	46	7	1	1					
<b>Total</b>	<b>541</b>	<b>197</b>	<b>621</b>	<b>111</b>	<b>57</b>	<b>45</b>	<b>13</b>	<b>5</b>	<b>4</b>	<b>5</b>	<b>2</b>

Phase	Fowl	Goose	Duck	Bird	Fish	Cod	Ling	Haddock	Salmon	Human
2	1	1								1
3	2	1		1	1	1	1			
4	23	4	1	2	1	1	2	2	1	
5	8		1							
<b>Total</b>	<b>34</b>	<b>6</b>	<b>2</b>	<b>3</b>	<b>2</b>	<b>2</b>	<b>3</b>	<b>2</b>	<b>1</b>	<b>1</b>

Of the few bones of pig, the bones from the Medieval phases indicated the slaughtering of pigs at all ages, from three months to over three and a half years old.

The basal fill [105] of ditch [100] (Phase 2b) yielded the partial skeleton of a horse of around 40 months old. All other horse bones were fused and so likely to have come from animals older than 40 months.

The sheep bones finding their way onto site appear to have derived largely from the domestic consumption of meat (especially in Phase 4), while the cattle bones may contain a mixture of discarded refuse from the slaughtering and butchering processes. Horse bones were also butchered, but no evidence of skinning cats or dogs for the fur or leather trade was observed, although this was common in Medieval Scotland (Smith 1999).

The metrical data obtained fell within the normal range for Scottish livestock from the 12th to 18th centuries. A small increase in the size of sheep was noted over time, possibly occasioned by the introduction of new strains of stock, while cattle remained about the same size but became more gracile as their use for hauling ploughs and wagons became less important.

Estimated live-weight of sheep in the Medieval phases fell in a range of 30.2kg to 41.5kg, calculated by regression analysis (Bond & O'Connor 1999, 407). Two sheep from Phase 4 (Post-Medieval) yielded live-weights of 36.3kg and 41.1kg, suggesting a slight increase in size. A further clue to the possibility of a change in the conformation of the sheep is the proportion of horned to hornless (polled) sheep. In Phase 3, of eight sheep skulls recovered, four were polled; in Phase 4, all five skulls bore horns.

#### 6.4.2 Calton Road

A total of 1,262 items of faunal bone were recovered from four large soil horizons and associated features, of which 912 (72.3%) were identified to species and bone level. Due to the limited sample size, the data from Phases 2 and 3 were combined for some analyses. Phase 1 contained too little material for meaningful analysis.

Sheep/goat (48%) and cattle (42%) made up the overwhelming majority of the individual bone fragments identified. Pig bones (mature and immature) account for 1.4% (13 bones) of the assemblage and horse bones 0.9% (eight bones). The other animals represented in the hand-excavated sample were dog (six bones), roe deer (six bones), cat (five bones) and rabbit (two bones). The sieved soil samples contained only two further small mammal species, the house mouse (*Mus musculus*) and the rat (*Rattus* sp.).

Of the bird species, domestic fowl were most common, represented by fourteen bones, with one bone each from greylag goose and rock dove/pigeon, both likely to have been the domesticated forms.

Very few fish bones were recovered; ling was the only large fish represented (both by head-bones and vertebrae), while herring and haddock were identified in small numbers from most of the soil sample retents.

As regards cull patterns, the material from Phase 2, though scarce, shows most cattle to have lived to full maturity. Phases 3 and 4 show a similar pattern, with around 75% of animals surviving to full maturity at over 42 months, although one mandible (of five) in Phase 3 was from a calf of under six months old, presumably slaughtered for veal. It is suggested that this pattern indicates animals kept for their secondary products, i.e. milk and traction, rather than for meat. A proportion (around 25%) of the animals, presumably bullocks excess to requirements for breeding or traction, was slaughtered before full maturity for meat.

In Phase 2 sheep less than half of the bones and teeth analysed were from animals of over three years old at slaughter. No young lambs were recovered and, of the animals slaughtered before full maturity, nearly half of the flock were killed in their third year. In the two later phases, most animals were slaughtered at over three years old, but young lambs were also slaughtered and there appears to be less of a peak of slaughter at two to three years old.

In the earlier phase, meat production appears to have been more important, and slaughter occurred after the animals had reached adult, or near-adult, weight (although most would have produced two fleeces by the time of culling). In the two later Post-Medieval phases, there was a cull of young lambs, possibly to meet a demand for more delicate meat in the city, although mutton was still more commonly eaten. In these phases, the mutton appears to derive from flocks kept primarily for wool production, with some excess stock sold for meat.

Body part representation analysis was carried out for cattle and sheep/goat in order to ascertain whether the site had received only the detritus from consumption of meat, or from the initial butchery and dressing of carcasses. The results for sheep in Phase 2 suggested that waste from both butchery and from consumption of mutton was finding its way onto the site at this time. In all subsequent phases there was a relative over-abundance of bones from the meatier parts of the carcass. This suggests that less butchery waste was deposited on the site in these phases, and the bones derive more from domestic consumption.

Analysis failed to show any significant biases in the anatomical distribution of cattle bones for any phase. When the figures for both Phases 2 and 3 were combined, the relative amounts of bone from the high- and low-meat yielding parts of the carcass showed a significant bias towards high meat. It does seem likely, however, that both low-meat and high-meat waste from cattle carcasses were deposited on site.

Only 15 cattle bones were sufficiently intact for any measurement (of which eight were phalanges),

all measurements are within normal ranges of Post-Medieval cattle. Although sparse, the data suggest that cattle toes decreased in size over time, possibly as a result of there being less dependence on cattle as draught animals. The sheep bones also yielded relatively few measurements, but it is possible to detect a general increase in size over time. The reconstructed live-weights of sheep (Bond & O'Connor 1999, 407) range from 30.2kg in Phase 2 to a mean of 36.4kg in Phase 4 (n = 4, maximum 39.5kg, minimum 34.5kg). These weight-ranges compare well with the general increase in sheep size observed at Holyrood Road.

One dog tibia recovered from Phase 3 was of a remarkable size. Although broken, a conservative estimate of its greatest length yielded a reconstructed shoulder height of over 0.69m for the dog. This result lies outside the range for any dog recovered from a Medieval site in Scotland (Smith 1999). The robustness of the bone suggests a large hunting dog, similar to a deer- or wolf-hound.

#### 6.4.3 Discussion

In both sites, sheep/goat and cattle were the most common species recovered, and comparatively low numbers of pig bones were present. This pattern is common in assemblages from Medieval sites in Edinburgh, the Canongate and Leith, with sites from most other Scottish burghs yielding a higher proportion of pig bones (see, for example, Smith & Hodgson 1987; Hamilton-Dyer et al 1993). Essentially the same pattern of butchery was recorded from both Holyrood Road and Calton Road. Cattle, sheep and pigs were all split into sides of meat with the head still attached to the body, and only removed later. Some sheep skulls were split while still attached to the neck. In the case of cattle, marks on the back of the jaw show that the mandible was chopped off the skull from beneath, in order to facilitate removal of the tongue. It is most likely, given cultural factors, that horse-meat was used to feed dogs rather than people, although it is also likely that a Scot has never been certain of the contents of his pie.

Both sites yielded deer bones. In contrast, a largely domestic site in Leith (Henderson 2002) with almost twice the number of bones examined as the two current sites combined, yielded only a single deer bone. It seems likely that at both sites this reflects a relatively high status of the inhabitants in the locality. The importance of red deer in the area is demonstrated by the fact that the arms of the Burgh of the Canongate feature a deer's head crowned with a cross, after a vision seen by David I while hunting in the vicinity.

The cull pattern for cattle is broadly similar for both sites. In the later Post-Medieval phases, some stock was slaughtered at prime meat age for beef, perhaps as the expanding city market made this economically viable. Both sites appear to indicate an increase in the importance of wool production

towards the later part of the Post-Medieval era, although there appears to be an increasingly viable market for lamb/kid at this time also.

The anatomical distribution analyses for the two major food-forming species at both sites revealed similar results. In both cases it seems that mutton was imported to the site as prime joints of meat, while beef was possibly more intensively used, with lower-value parts of the carcass also being consumed.

The species present in both sites are typical of urban Medieval and Post-Medieval sites in and around Edinburgh. Of the small animal species represented, Calton Road contained mouse and rat bones only, while Holyrood Road showed evidence of a damper environment, with water vole and frog bones also being present. In both sites, fish bone is scarce, with herring predominating and very small numbers of haddock, other small gadoids, cod and ling present.

#### 6.5 *X-ray diffraction of Calton Road bone, by Clare Ellis*

##### 6.5.1 Introduction

The animal bone from the Calton Road excavation seemed exceptionally heavy. Subsequent laboratory analysis suggested that the hydroxyapatite, the main mineral constituent of bone, had either been largely replaced, or at least masked, by non-hydrochloric acid-sensitive minerals. Various explanations were proposed, although without the identification of the replacement or masking mineral these explanations would remain speculative. Funding was granted by Historic Scotland to carry out X-ray diffraction (XRD) on five bone samples to identify the crystalline mineral phases of the samples.

##### 6.5.2 Method

Four samples of animal bone were taken from the four main stratigraphic layers (bottom to top), [247], [237], [203] and [202] and analysed for the crystalline mineral composition by XRD, powder technique. A fifth sample was used as a control; this animal bone was derived from Roman Inveresk, East Lothian. The XRD was carried out by Mr G. Angel at the Department of Geology, University of Edinburgh.

##### 6.5.3 Results

XRD analysis revealed the mineral component of the control bone was hydroxyapatite (a mixture of calcium and phosphate); the XRD pattern follows the norm for animal bone (Sillen 1989). However, the bone from Calton Road contained hydroxyapatite and crystalline silica (quartz). XRD does not

allow for the calculation of proportions and therefore the amount of quartz within the Calton Road bone cannot be quantified.

There are three possible explanations to the presence of silica within the Calton Road bone. The first is that the silica was ingested as part of the diet and is a natural component of the bone. The second is that a proportion of the hydroxyapatite has been replaced by silica during silicification (or petrification). The third explanation is a process known as permineralisation, where silica has infilled original interstices and pore space of the bone (Sigleo 1978; Lau pers comm). The first explanation is linked to diet, while the second and third involve post-mortem and post-depositional diagenetic processes.

Diet – hydroxyapatite is the most common component of bone, with a variety of trace elements present. Many trace elements, most commonly strontium (alkaline earth metal), zinc and magnesium, have been shown to be derived from plant and, less frequently, animal matter. However, the author is not aware of any evidence in the literature for diet-derived silica (amorphous or crystalline in form) being incorporated into bone (see Douglas Price 1989). Given that all the bone on site has a silica component, it seems very unlikely that a special or unusual diet, not documented elsewhere, was taken by animals from the 14th to 18th centuries.

Silicification – after burial, acid soil and groundwater conditions can lead to the dissolution and removal of hydroxyapatite. The solubility of hydroxyapatite increases rapidly below pH of 6 (Buikstra et al 1989). Hydroxyapatite in bones can be replaced by elements such as iron, potassium, aluminium and manganese, silica and barium (Douglas Price 1989). The soil at Calton Road was generally acid, pH 5.2 to 5.5. Despite the underlying geology being a calciferous sandstone, the soils in which the bones were recovered were rich in organic matter, which on decomposition has an acidifying effect and hence it is likely that these particular soils were always acidic in nature.

The XRD pattern clearly demonstrates the presence of hydroxyapatite, which therefore must have been shielded from the acidic groundwater, presumably by the organic phase of the bone (Sillen 1989). Furthermore, it is clear from the broad peaks of the XRD pattern that the crystallinity of the apatite is low. As expected, this demonstrates that the bone has not undergone any fossilisation, which typically manifests itself in the first few thousand years of burial (Sillen 1989). However, silica can also replace surface apatite as a result of complex surface reactions (Clarkson 1979). Without further analysis, i.e. thin section and SEM, the process of silicification cannot be ruled out, but is perhaps an unlikely explanation given the relatively recent date of the bones.

Permineralisation – the most likely explanation is that the silica lies within the original interstices and pore space of the bone. It is unusual, but silica is known to be soluble in water under normal

pressures and temperatures (20°C) and at pH9 or above (Sigleo 1978 and Hazeldine pers comm). Highly alkaline conditions can be generated during bacterial decay; the soluble silica then precipitates out of solution wherever the pH is lower (Clarkson 1979). The interstices and pore spaces of bones would be such an environment within which silica could precipitate as a gel.

The source of the soluble silica at Calton Road has not been identified. In geological settings the source of soluble silica is often fossils. The underlying Carboniferous Cementstone Group, a calcite-rich sandstone formed under warm marine conditions, could therefore possibly be the source of the silica. Alternatively, building works in the 19th century may have introduced mortar and lime putty into the soils, causing very high, but localised, alkaline conditions (Clydesdale pers comm).

The lower levels of stratigraphy on site (approximately 4.5m below current ground level) were waterlogged, indicative of a high water table. The groundwater, which must have fluctuated in level with the draining of the Nor Loch and canalisation of local burns, may therefore have contained soluble silica either derived from the calciferous sandstone or from soils saturated with mortar. When the groundwater came into contact with the slightly acidic soils the soluble silica would have precipitated out of solution, including some within the pores of the animal bones.

#### 6.5.4 Conclusion

The bone incorporated hydroxyapatite and quartz; further work would be required to confirm the working hypothesis that the quartz lies within the interstices and pore spaces of the bone. This quartz is thought to have precipitated out of solution through a process known as permineralisation. The source of the silica has not been positively identified, but is most likely to be either the underlying hard-rock geology or lime putty pits and mortar contamination from the 19th century. However, modern contamination cannot be ruled out.

As a footnote, while choosing bone for analysis it was noted that the Medieval and Post-Medieval bone from the Holyrood Road excavation shared similar, but less pronounced, characteristics to that from Calton Road. The implication is that the post-depositional physico-chemical process occurring at Calton Road was also present at Holyrood Road, if of lesser intensity. If this proves to be the case then this phenomenon would be expected to be observed at other sites within the capital where either similar geological and environmental conditions prevail or where significant building and associated mortar and cement land-contamination has taken place.

Finally, the effects of groundwater rich in dissolved minerals may have serious implications for analyses, such as diet studies and radiocarbon dating.

## 6.6 *Metal and slag, by Andrew Heald and Stuart Campbell*

### 6.6.1 Introduction

The majority of finds from both sites were slag, mainly indicative of ironworking. The iron, lead and copper alloy objects are typical finds from Medieval sites, indicative of dress accessories, tools and structural fittings. As such they are valuable in that they supplement and enhance the corpus of knowledge of metal objects from other Scottish Medieval sites: e.g. Perth (Ford 1987; Ford 1987a; Spearman 1987); St Andrews (Maxwell 1997); Castle Park, Dunbar (Cox 2000, 123–4); Fast Castle (Allan 2001) and Edinburgh Castle (Clark 1997a). It is not proposed to produce a full catalogue of the metal finds here, but, instead, a description of the slag and other metalworking evidence is provided, which, again, will add to the understanding of urban metalworking in Medieval Scotland (e.g. Spearman 1988; 1997). This is followed by an interpretative discussion on all the metal evidence retrieved from the sites. The catalogue and full report on the metal finds may be obtained from the site archive.

### 6.6.2 Slag

4,345g of material was broadly classified by visual inspection. Further elemental and mineralogical analyses would be necessary to classify the material more conclusively. The slag has been described using common terminology (e.g. Spearman 1997). The majority appears to be associated with smithing; it is possible that some of the slag is associated with bloomworking (M. Spearman pers comm). The remaining material is either slag not indicative of metalworking, only of an unidentifiable pyrotechnic process, or fuel remains, usually coal. For full catalogue see archive report.

Smithing hearth bottoms and smithing slags – the majority of this material would have been extruded and discarded during the repeated forging of iron blooms to produce serviceable wrought iron, or additional smithing activity. Four pieces are plano-convex in shape and can be classed as hearth bottoms, accumulations of slag that developed in the hearth during working (1,525.42g). The majority of other pieces are unstructured smithing fragments, apparently broken from larger masses. This accounts for 1,713.38g of the slag from Holyrood Road and 149.70g from Calton Road.

Slag spheres – a minute amount of slag spheres (0.2g) was found at Holyrood Road. This results from the solidification of small droplets of liquid slag expelled during ironworking. When found in sufficient quantities they are usually indicative of *in situ* smithing.

Unclassified slags – this group contains all fragments that do not have enough of their external surfaces to place them in any of the standard classes.

The magnetic attraction and traces of iron scale within some of the matrices suggest that some of the pieces may be residues of smithing. This accounts for the majority of the ironworking slag from Calton Road.

Amorphous burnt plant material (fuel remains) – a significant proportion of material classed as ‘slag’ during excavation was amorphous burnt plant material, usually coal, which survived either as individual pieces or fragments mixed with smith debris. Much of the coal was recovered in the form of small granules (less than 3mm across) and is likely to have been formed from debris and unburnt fuel settling within a hearth. This accounts for a significant proportion of the material from Calton Road (134.8g) and a smaller amount from Holyrood Road (27.64g).

Fuel ash slag – the remaining finds are vitrified fuel ash, slag formed when material such as earth, clay, stones or ceramics are subjected to high temperatures, for example in a hearth. During heating these materials react, melt or fuse with alkali in ash, producing glassy (vitreous) and porous materials. These can be formed during any high-temperature pyrotechnic process and are not necessarily indicative of deliberate industrial activity.

### 6.6.3 Discussion

The copper alloy, iron and lead objects can be readily paralleled on a number of other Scottish Medieval sites, for example Perth (Holdsworth 1987), St Andrews (Rains & Hall 1997) and Edinburgh Castle (Driscoll & Yeoman 1997). Only a few of the objects can be dated closely.

One of the aims of the excavations at Holyrood Road and Calton Road was to compare the nature of activities between the two sites; in order to tease out further patterns it is useful to analyse the finds distribution.

The majority of finds from both sites were recovered from secondary contexts, particularly the general soil horizons. Reconstructing *in situ* activity, particularly metalworking areas, is difficult. Taking the evidence from the soil layers from Holyrood Road as an example, there are no slag clusters to indicate probable ironworking areas. The remaining objects were mainly from ditch or pit fills, representing the opportune deposition of material.

The majority of metalworking evidence was found at Holyrood Road, mostly residual slag from Medieval soils [009] and [011] (Phase 3). The recovery of industrial debris is hardly surprising – ironworking slags are a common find on many Scottish Medieval burgh sites (Spearman 1988, 162). *In situ* structures, such as forges and smithies, have been found (e.g. Edinburgh Castle: Driscoll & Yeoman 1997, 49–56). It was in the burgh backlands that craft workers often had their workshops, situated at the rear of a craftsman’s property, while the finished products were sold in a shop on the frontage. It is within this

light that we should perhaps interpret the evidence from Holyrood Road and Calton Road.

By looking beyond Holyrood Road we can begin to analyse possible variations in working practices between areas within the Canongate and Edinburgh. The majority of slag recovered from Holyrood Road was associated with smithing but, while it is uncertain from visual analysis alone, it is possible that some of the slag is residue from bloomworking. Slag of this type has been found on a number of urban Medieval sites and it is possible that iron blooms were imported into the towns where they were further refined and worked (see Spearman 1988, 162–3). In contrast, at Edinburgh Castle two groups of ironworking debris were noticeable by their absence – tap slags (indicative of smelting) and bloomworking. This, together with the large amounts of evidence for wrought ironworking, led Spearman (1997, 167–8) to conclude that the Edinburgh Castle smiths were primarily involved in the repair and manufacture of wrought iron and not the conversion of bloomery iron into wrought iron. These patterns may suggest that different areas were involved in different stages of the ironworking cycle. The wide range of demands for tools and smithing work in centres such as Edinburgh makes a division in production and specialisation likely (Spearman 1988, 167; Spearman 1997, 168; Ewan 1990, 34–5).

#### 6.6.4 Conclusion

The majority of finds from both sites were slag, indicative of ironworking. The iron, lead and copper alloy objects are typical finds from Medieval sites.

### 6.7 *Macroplant remains, by Patrice Vandorpe*

#### 6.7.1 Introduction

At both sites the preservation of the plant remains was generally poor and thus a large proportion of identification was not taken beyond genus level. The use of the four main cereal species (barley, oats, wheat and rye) is attested.

#### 6.7.2 Holyrood Road

The charred plant remains were recovered from the fills of ditch [100] and other features such as pits, wells, cultivation marks, a corn-drying kiln and various soil layers (Table 5). Cereal grains constitute the majority of the plant remains. Three major crops are represented: barley, oats and wheat. In most cases, the grains alone were recovered. Parts of cereal other than grain, e.g. glume bases and rachis fragments, were present in very small numbers.

Barley grains (*Hordeum vulgare*) were most

common throughout the assemblage, which is characteristic for Medieval Scotland (Greig 1991). A small quantity was tentatively identified as of the hulled variety.

Oats (*Avena* sp.) were present in the form of naked grains. The absence of the diagnostic chaff fragments prevented more specific identification. On the basis of size and general shape, it is likely that some of the poorly preserved grass caryopses, in this analysis classified as Poaceae, are oat grains. Given the numbers recovered it is likely that they represent the remains of a cereal crop, either bristle oat (*Avena strigosa*) or common oat (*Avena sativa*). These were both common in Scotland from the Roman period onwards (Boyd 1988).

Wheat (*Triticum* sp.) is the second commonest cereal in the assemblage. A small number of grains were positively identified as bread wheat (*Triticum aestivum*). Again due to poor preservation, most of the grains were recorded as possible bread wheat, bread wheat/emmer or indeterminate wheat grains. Five possible spelt grains (*Triticum spelta*) were recovered from Medieval soil [011] (Phase 3). Unfortunately, no identifiable chaff fragments were recovered to sustain the identifications of bread wheat and spelt wheat as the grains are morphologically difficult to distinguish.

Rye (*Secale cereale*), another Medieval mainstay crop (Greig 1991), was positively identified in [065], as were three flax seeds (*Linum usitatissimum*). Hazelnut shell (*Corylus avellana*) was recorded in six samples. Other economic species included one lentil seed (*Lens culinaris*) from the fill of a cultivation slot [052] (Phase 4) and one vetch seed (*Vicia* sp.) from soil [008] (Phase 5).

Two samples from the Medieval soil layer [011] (Phase 3) located in the south-east of the site (Test-pits 29 and 50) contained a significant amount of barley and bread wheat grains. Few weeds other than grass seeds were recovered.

Three refuse pits [096], [098] and [118], all Phase 3, produced over 90 plant items. The composition of charred plant remains within these pits is very similar. Cereal remains are present in small quantities; grass seeds are largely represented and so are seeds of the goosefoot family. The latter are frequently found in Medieval urban deposits. The grass seeds could, as mentioned above, be oat grains. The middle fill [078] of Pit [073] (Phase 3) yielded 108 charred plant remains, which were mainly goosefoots.

By far the greatest number of plant remains was recovered from context [065], i.e. 2,038 elements were quantified. This was taken from an organic-rich deposit found within the 'entrance' of a Phase 3 stone-built structure [064] identified as the probable remains of a grain-drying kiln. The plant assemblage recovered consists of approximately 55% cereal remains and 45% weed seeds. The cereal remains are mainly barley, oat and indeterminate cereal grains, with occasional wheat and rye grains. No chaff fragments were recovered. The weed seeds recovered are generally associated with cultivation

Table 5 Holyrood Road: macroplankton content of selected contexts

Context	Volume (litres)	Common name	[011] TP29	[011] TP50	kiln deposit [065]	[078] fill of pit [073]	[095] fill of pit [096]	[114] fill of pit [098]	[115] fill of pit [098]	[117] fill of pit [118]	Total
			19	20	3	20	20	16	6	16	
Non-domesticates			108	142	822	82	86	61	62	200	1563
Leguminosae		Legume family			11					1	12
<i>Linum usitatissimum</i>		Flax			3						3
<i>Avena</i> sp.		Oat	3		107	6		1		40	157
cf <i>Avena</i>		cf Oat	44	8	27			5			84
<i>Hordeum vulgare</i> , cf hulled		Cultivated barley, hulled			8						8
<i>Hordeum vulgare</i>		Cultivated barley	29	20	363		3	6		36	457
<i>Hordeum</i> sp.		Barley	27			5				39	71
<i>Hordeum rachis</i>		Barley rachis			13						13
<i>Triticum aestivum</i>		Bread wheat	3		15		10	1	11		40
<i>Triticum</i> cf <i>aestivum</i>		Bread wheat	20	4	4	1	9	6	11	37	92
<i>Triticum aestivum</i> / <i>dicoccum</i>		Bread wheat/emmer wheat	12								12
<i>Triticum</i> cf <i>spelta</i>		Spelt	5								5
<i>Triticum</i> sp.		Wheat	35	4		3	38	8	4	69	161
<i>Secale cereale</i>		Rye			32						32
cf <i>Secale cereale</i>		cf Rye			21					6	27
<i>Triticum</i> / <i>Secale</i>		Wheat/rye			36						36
<i>Cerealia</i> indet.		Cereal		4	476	10		4	4		498
Unidentifiable			4		100	1	6		3	6	120
<b>Total</b>			290	182	2038	108	152	92	95	434	<b>3391</b>

ground, such as corn marigold, chickweed, sheep's sorrel and corn spurrey. Most of these grow on acid sandy soils, rich in nutrients and are found in spring cereals (Hanf 1983). The assemblage of this sample [065] is very similar to those retrieved from the Medieval corn-drying kilns at Abercairny, Perthshire, analysed by Fairweather (1989), and at Capo, Kincardineshire (Dickson & Dickson 2000). At Abercairny, the cereals (mainly barley and bristle oat) comprised half the sample. The deposit was interpreted as the remains of successive kiln firings (ibid). Given the location of the sample at the 'entrance' of the structure, it is likely to result from similar practices.

Non-domesticated species (weeds) were present in the samples in very small numbers. These included cornfield weeds such as corn marigold (*Chrysanthemum segetum*), chickweed (*Stellaria media*), corn spurrey (*Spergula arvensis*), sheep's sorrel (*Rumex acetosella*) and sun spurge (*Euphorbia helioscopia*). Weeds characteristic of the Medieval urban flora, such as goosefoots (Chenopodiaceae) and knotweeds (Polygonaceae) were also recorded (Greig 1991). Other weeds present are indicative of grassland, wasteland and damp locations.

### 6.7.3 Calton Road

The majority of the charred plant remains consisted of very small numbers of cereal grains, in particular barley (*Hordeum vulgare*); a few wheat grains and some possible bread wheat grains (*Triticum* cf *aestivum*). Non-domesticated species included sun spurge (*Euphorbia helioscopia*), goosefoots (Chenopodiaceae), sedges (*Carex* spp) and grasses (Poaceae), all indicative of cultivated ground and waste places.

### 6.8 Glass, by Jill Turnbull

Of the glass recovered from the Calton Road and Holyrood Road sites, most consisted of small weathered shards of window glass, very thin and fragile and probably dating to the 17th century. Larger fragments are from 'black' (i.e. dark olive green) wine or ale bottles from the 18th or 19th centuries. There was a small scattering of fragments of soda vessel glass, probably 17th-century, on both sites, which together with the very fragile window glass indicates the presence of some fairly high-status buildings in these areas.



---

## 7 THE SIGNIFICANCE OF THE EXCAVATIONS

---

The approximate length of the Medieval burghage plots at Calton Road and Holyrood Road sites would have been roughly 160m and 120m respectively. At both sites archaeological survival is limited to the extremities of the backlands, the final 25m or so, well removed from the commercial and domestic focus of the Canongate frontage. The Holyrood Road excavation, despite suffering considerable truncation, provided the greater range of features, probably by virtue of its specific location, immediately adjacent to the 'back dyke', and its greater size.

Much of the artefactual data was recovered from general soil layers, especially at the Calton Road site. Although this evidence might otherwise be compromised by the question of its origin – whether natural formation, the dumping of soils or the continual building and collapse/erosion of turf-built structures (see Clark 1997, 142; Carter 2001, 87–92) – there seems no reason to suggest that any soil imports, if they occurred, were from outwith the direct locality or that artefact inclusion occurred after any importation.

Key amongst the discoveries was the sequence of burgh boundary features, including an early ditch. As in England, prior to the 13th century Scottish Medieval town defences generally consisted of a ditch and bank, occasionally topped by a palisade (Barley 1975, 60), with gateways for the control of people and goods into the burgh. Indeed, some towns never progressed beyond earthwork boundaries, as at Dunfermline, Old Aberdeen and Inverness (Brann et al 1995, 928). Historical references, morphology and/or the large size of some of these features – for example, the 14th-century ditch found at South Methven Street, Perth – clearly indicate a military rationale (Spearman 1987a, 58). The putative 12th-century ditch found at Mill Street, Perth (Sermon & Cox 1996, 739) as well as burgh ditches recently investigated elsewhere in Scotland, at Inverness (Ellis 2002) and at Annan (Toolis & Cavanagh 2002) illustrate the variation in size, date and form of these features. The early ditch identified at the Holyrood Road site was on a different alignment from a north-east/south-west-aligned ditch feature of similar scale identified, to the east, at the Parliament excavation (HAPT 2008, 18–19). The feature at the Parliament site has been interpreted by Stronach as being associated with the Holyrood Abbey precinct, enclosing an area of cultivation. This view is supported by a paucity of related features and artefactual remains, in contrast to the Holyrood Road ditch. Stronach postulates that the Parliament ditch returned northwards towards the Canongate somewhere in the vicinity of Reid's Close, and therefore it would not be linked to the ditch identified at the Holyrood

Road site (HAPT 2008, 52–53). The identified sequence of boundaries at Holyrood Road saw the Canongate ditch superseded by a 13th/14th-century palisade and then in turn by an early 16th-century wall. Most Scottish burghs were never enclosed by a purpose-built defensive wall, instead relying on the typical later Medieval 'back dyke' (Hall et al 1998, 818) to define and control economic and legal access to a burgh as at Culross, Linlithgow, St Andrews, Glasgow and Elgin (Mair 1988, 31). The wall's remains point to such a role, with its construction reflecting the increased importance of the Canongate with the presence of the royal palace at Holyrood. Given that late 17th-century cultivation slots overlay this wall, the remains of further burgh walls (e.g. the wall shown on Gordon's 1647 map) may lie to the south below the Holyrood Road pavement, as indeed may further, earlier phases of Medieval boundaries.

Pre-14th-century pottery types were found to be lacking from the Calton Road site, as were the more complex Medieval domestic features found during the Holyrood Road excavation. This could indicate that the burgh, as always assumed, originated adjacent to the Abbey with Medieval activity, perhaps of lesser intensity, occurring later at the Calton Road site than at Holyrood Road as settlement gradually expanded westwards towards Edinburgh. Domestic features and artefacts encountered at both sites are typical of those found on similar Medieval/Post-Medieval sites elsewhere in Scotland. The key linkage between Medieval urban and agricultural life (Moloney & Coleman 1997, 779) is exemplified by the discovery of a corn-drying kiln.

The sparse evidence for Medieval backland division at Holyrood Road is perplexing. Either truncation has destroyed these features and/or they were ephemeral in character, perhaps simple wattle fences, with no trace surviving. Alternatively, some variation in burgh planning, derived from the higher social status of the burghage plot owner or the wider usage of the backland, dictated a larger size. Coleman (2004, 288) cites the bias in land allocation (as seen in burghage plot width) in favour of the canons of Glasgow Cathedral in Glasgow and the wide industrial zones in Perth and Rattray, Aberdeenshire. In this regard the tentative proposal by Heald and Campbell (6.6 above) of possible specialist bloomworking, perhaps requiring additional space in the locality, may be relevant. The Parliament excavation has demonstrated that plot divisions in the adjacent area were marked by ditches and were relatively wide, at a minimum of *c* 13m, though the possibility of other boundary features such as hedgelines has been put forward (HAPT 2008, 20–

21). The Parliament excavation also demonstrated a relatively low level of activity in the Medieval backlands in this area, though with some suggestion of variation in use between plots, for processes such as tanning. Stronach suggests that the lack of development of these backlands may be a sign of high-status occupancy (HAPT 2008, 54–55).

Conversely, at Calton Road, from Phase 2 to the Post-Medieval phases, there is an approximate recurrence of a north–south subdivision through the central part of the trench. The 6m to 7m distance between the Phase 2 (15th/16th-century) path [240] and small ditch [233] perhaps indicate a typical width for the Canongate burgage plots at this time.

This corresponds well with the plot widths generally found elsewhere in Scottish towns (see Coleman 2004, 284–288).

The presence of 17th-century ceramic imports supports cartographic and historical sources as to the prosperous nature of early to mid 17th-century Canongate. However, by the latter part of the century, the rich garden soils of once elegant formal gardens were turned over to more mundane crop cultivation, as seen at the Holyrood Road site, with the Canongate now in social decline. This social decline, some 300 years later, has been firmly arrested by the location of the new Scottish Parliament.

---

## 8 ARCHIVING

---

The primary records from both excavations together with the full specialists' reports are archived with the National Monuments Record of Scotland. The

artefact assemblages have been submitted for allocation through the Finds Disposal Panel.

---

## 9 ACKNOWLEDGEMENTS

---

Teague Homes Ltd financed the Holyrood Road excavation while Barratt East Scotland Ltd funded the Calton Road Project. Historic Scotland provided funding for the XRD analysis of the Calton Road animal bone. Thanks are due to all the archaeologists who worked on the sites, in particular Jamie Hamilton for his contribution at the Holyrood Road site.

Dennis Gallagher would like to thank Dr Peter Anderson of the National Records of Scotland for his help in attempting to transcribe the inscribed clay pipe stems.

The artefact illustrations are by Andrew Aspinall (clay pipes) and Graeme Carruthers (clay pipes and ceramics). Site drawings are by John Gooder.

---

## 10 REFERENCES

---

- Allan, S W 2001 'Ordnance', in K L Mitchell; K R Murdoch and J R Ward (eds), *Fast Castle. Excavations 1971–86*, 109–13. Edinburgh.
- Atkinson, D & Oswald, A 1969 'London Clay Tobacco Pipes', *Journal British Archaeological Association* 32, 171–227.
- Avery, B W 1980 *Soil Classification for England and Wales (Higher Categories)*. Soil Survey Technical Monograph No. 14, Harpenden.
- Barley, M W 1975 'Town defences in England and Wales after 1066', in M W Barley (ed) *The Plans and Topography of Medieval Towns in England and Wales*, London, 57–71. (= *CBA Res Rep*, 14).
- Barrow, G W S (ed) 1999 *The Charters of David I: the written acts of David I, King of Scots, 1124–53, and of his son, Henry, Earl of Northumberland, 1139–52*. The Boydell Press, Woodbridge.
- Boessneck, J 1969 'Osteological Differences between Sheep (*Ovis aries* L) and Goat (*Capra hircus* L)', in D R Brothwell and E S Higgs (eds) *Science in Archaeology*. Thames & Hudson, London.
- Bonar, A 1856 *The Canongate Ancient and Modern: its History and Remarkable Buildings*. Edinburgh.
- Bond, J M and O'Connor, T P 1999 'Bones from Medieval Deposits at 16–22 Coppergate and Other Sites in York', in P V Addyman (ed) *The Archaeology of York: The Animal Bones*, 15/5. CBA, York.
- Borremans, R & Warginaire, R 1966 'La céramique d'Andenne: Recherches de 1956–1965', *Stichting het Nederlandse Gebruiksvoorwerp*.
- Boyd, W E 1988 'Cereals in Scottish Antiquity', *Circaea* 5.2, 101–110.
- Brann, M; McGavin, N and Bowler, D 1995 'Mill Street', in D Bowler; A Cox; A and C Smith 'Four excavations in Perth, 1979–84', *Proceedings Society Antiquaries Scotland* 125, 917–999.
- Brooks, C 1980 'Medieval pottery from the kiln site at Coulston, East Lothian', *Proceedings Society Antiquaries Scotland* 110, 364–403.
- Buikstra, J; Frankenberg, S; Lambert, J B and Xue, A L 1989 'Multiple elements: multiple expectations' in T Douglas Price (ed) *The Chemistry of Prehistoric Human Bone*. Cambridge University Press, Cambridge.
- Caldwell, D & Dean, V 1992 'The pottery industry at Throsk, Stirlingshire, in the 17th and early 18th century', *Post-Medieval Archaeology* 26, 1–46.
- Carter, S 2001 'Reassessment of the origins of the St Andrews garden soil', *Tayside Fife Archaeological Journal* 7, 87–92.
- CECAS 1991 *Holyrood Brewery, Canongate, Edinburgh: archaeological assessment*. Unpubl. City of Edinburgh Council Archaeology Service archive report.
- CECAS 1997 *Calton Road, Edinburgh: archaeological evaluation*. Unpubl. City of Edinburgh Council Archaeology Service archive report.
- Chambers, R. 1996 *Traditions of Edinburgh*. Edinburgh (originally published in 1824).
- Chapelot, J 1972 'L'artisanat céramique en Saintonge, XIIIe-XIXe siècles', *Rapport préliminaire*, Paris.
- Chenery, S; Phillips, E & Haggarty, G 2004 'An evaluation of geochemical fingerprinting for the provenancing of Scottish Red Ware Pottery', *Medieval Ceramics* 25, 45–53.
- Clark, A 1979 'French Wares', in C Gaskell Brown *Plymouth Excavations: Castle Street, The Pottery*. City Museums and Art Gallery, Plymouth.
- Clark, J 1976 'Appendix C German Stoneware', in J Schofield 'Excavations south of Edinburgh High Street 1973–4', *Proceedings Society Antiquaries Scotland* 107, 206–11.
- Clark, J 1997a 'Medieval copper-alloy artefacts', in S T Driscoll and P A Yeoman (eds), 149–53.
- Clark, P R 1997 'Discussion', in M J Rains and D W Hall (eds) *Excavations in St Andrews 1980–89*. Tayside Fife Arch Comm Monogr 1, 141–143. Glenrothes.
- Clarkson, E N K 1979 *Invertebrate Palaeontology and Evolution*. George Allen & Unwin, London.
- Coleman, R 2004 'The archaeology of burgrave plots in Scottish Medieval towns: a review', *Proceedings Society Antiquaries Scotland* 134, 281–323.
- Cowan, W & Inglis, H R G 1919 *The Early Views and Maps of Edinburgh 1544–1852*. The Royal Scottish Geographical Society, Edinburgh.
- Cox, A 2000 'Copper Alloy Objects', in D R Perry (ed), *Castle Park, Dunbar. Two Thousand Years on a Fortified Headland*, 115–25. Edinburgh (= *Soc Antiq Scot Monogr Ser*, 16).
- Cox, A and Hall D 2008 'Summary of the artefactual evidence for Periods 1–5' in Holyrood Archaeology Project Team (HAPT), *Scotland's Parliament Site and the Canongate*, Edinburgh (= *Soc Antiq Scot Monogr Ser*, 32).
- Cox, E 1984 'Ceramic material', in C J T Tabraham 'Excavations at Kelso Abbey', *Proceedings Society Antiquaries Scotland* 114, 381–98.
- Crowdy, A 1986 'The pottery', in P Dixon *Excavations in the Fishing Town of Eyemouth 1882–1984*. Border Burgh Archaeol Project Monogr Ser 1, Edinburgh.
- Davey, P J (ed) 1985 'Clay pipes from Norton Priory, Cheshire', in P Davey (ed) *The Archaeology of the Clay Tobacco Pipe IX*, 157–236. BAR, Oxford (= BAR, Brit. Ser. 146).
- Davey, P (ed) 1985 *The Archaeology of the Clay Tobacco Pipe IX. More Pipes from the Midlands*

- and Southern England. BAR, Oxford (= BAR, Brit. Ser. 146).
- Davey, P (ed) 1987 *The Archaeology of the Clay Tobacco Pipe X. Scotland*. BAR, Oxford (= BAR, Brit. Ser. 178).
- Davey, P J 1992 'Dutch clay tobacco pipes from Scotland', in D Gaimster & M Redknapp *Everyday and Exotic Pottery from Europe c 650–1900* (= Studies in honour of John G Hurst), 279–89. Oxbow Books.
- Dean of Guild 1762–1863 *Edinburgh Dean of Guild Court Warrants*.
- Dennison, E P 2005 *Holyrood and Canongate, A Thousand Years of History*. Birlinn, Edinburgh.
- Dickson, C & J 2000 *Plants and People in Ancient Scotland*. Tempus Publishing, Stroud.
- Douglas Price, T 1988 'Multi-element studies of diagenesis in prehistoric bone', in T Douglas Price (ed) *The Chemistry of Prehistoric Human Bone*. Cambridge University Press, Cambridge.
- Douglas Price, T 1988 (ed) *The Chemistry of Prehistoric Human Bone*. Cambridge University Press, Cambridge.
- Driesch, A von den 1976 *A Guide to the Measurement of Animal Bones from Archaeological Sites*. Peabody Museum of Archaeology and Ethnology, Harvard University Bulletin 1, Harvard.
- Driscoll, S T & Yeoman, P A 1997 *Excavations within Edinburgh Castle in 1988–91*. Edinburgh (= Soc Antiq Scot Monogr Ser, 12).
- Duco D H 1981 'De Kleipijp in de Zeventiende Eeuwse Nederlanden', in P Davey (ed) *The Archaeology of the Clay Tobacco Pipe V. Europe 2*, 111–468. BAR, Oxford (= BAR Internat Ser 106(ii)).
- Edwards, L 1988 'Seventeenth- and eighteenth-century Tyneside tobacco pipe makers and tobacconists' in P Davey (ed) *The Archaeology of the Clay Tobacco Pipe XI*. BAR, Oxford (= BAR, Brit. Ser. 192).
- Ellis, C 2002 'Excavation of two ditches and a Medieval grain-drying kiln, Inverness', *Proceedings Society Antiquaries Scotland* 132, 425–438.
- Engelen, J P A M 1988 'Nijmegen' in F Tymstras, F and J van der Meulen (eds) *De Kleipijp als Bodemvondst*, 135–42. Pijpelogische Kring Nederland, Leiden.
- Ewan, E 1990 *Townlife in Fourteenth-century Scotland*. Edinburgh.
- Fairweather, A D 1989 'Appendix: carbonised grain', in A Gibson 'Medieval corn-drying kilns at Capo, Kincardine and Abercairny, Perthshire', *Proceedings Society Antiquaries Scotland* 118, 219–229.
- Ford, B 1987 'Copper alloy objects', in P Holdsworth (ed), 121–30.
- Ford, B 1987a 'Iron objects', in P Holdsworth (ed), 130–41.
- Gaimster, D 1988 'Post-Medieval ceramic stove tiles bearing the Royal Arms: evidence for their manufacture and use in southern Britain', *Archaeological Journal*, 145, 314–43.
- Gaimster, D; Goffin, R and Blackmore, L 1990 'The Continental stove tile fragments from St Mary Graces, London, in their British and European context', *Post Medieval Archaeology*, 24, 1–49.
- Gallagher, D B 1987a 'Edinburgh, Tron Kirk', in P J Davey (ed), 269–271.
- Gallagher, D B 1987b 'Edinburgh pipemakers in the seventeenth century: the documentary evidence', in P J Davey (ed), 3–13.
- Gallagher, D B 1987c 'Pipes for the Company of Scotland: the documentary evidence', in P J Davey (ed), 233–38.
- Gallagher, D B 1998 'Holyrood Abbey: the disappearance of a monastery', *Proceedings Society Antiquaries Scotland*, 128, 1079–1099.
- Goggin, J M 1960 'The Spanish Olive Jar: An Introductory Study', *Yale Univ. Publications in Anthropology*, Vol. 62, 1–37.
- Gooder, J 2000 *Calton Road Gasworks, Edinburgh: Evaluation Data Structure Report*. Unpubl. AOC Archaeology Group archive report.
- Gooder, J. 2007 'Wemyss', *Discovery Excav Scot* 7, 82.
- Gordon, J 1647 *Viro Amplissimo D. Archibaldo Todo*.
- Grant, A 1982 'The use of toothwear as a guide to the ageing of domestic ungulates', in Wilson, Grigson and Payne (eds) *Ageing and Sexing Animal Bones from Archaeological Sites*. BAR, Oxford (= BAR, Brit. Ser. 109).
- Grant, J 1882 *Cassell's Old and New Edinburgh: Its History, Its People and Its Places*. 3 vols. London.
- Greig, J 1991 'The British Isles', in W van Zeist; K Wasylikova and K Behre (eds) *Progress in Old World Palaeobotany*, 299–334. A. A. Balkema, Rotterdam.
- Grohne, E 1940 'Tongefässe in Bremen seit dem Mittelalter, untersucht auf Grund von Bodenfunden', *Jahresschrift des Focke-Museums*, Bremen.
- Haan, R de & Krook, W 1988 'Amsterdam', in F Tymstras & J van der Meulen (eds) *De Kleipijp als Bodemvondst*, 16–38. Pijpelogische Kring Nederland, Leiden.
- Haggarty, G 1980 'Post Medieval pottery in Scotland', *Scottish Pottery History Review* 5, 45–61.
- Haggarty, G 1980a 'The pottery', in G Ewart, 'Excavations at Stirling Castle 1977–78', *Post Medieval Archaeology* 14, 23–51.
- Haggarty, G 1984 'Observations on the ceramic material from phase 1 Pits BY and AQ', in C J T Tabraham 'Excavations at Kelso Abbey', *Proceedings Society Antiquaries Scotland* 114, 381–98.
- Haggarty, G 2004 'The Post-Medieval and later pottery from Wester Dalmeny Steading, Dalmeny'. Unpubl. report produced for CFA Archaeology Ltd.
- Haggarty, G 2006 'A gazetteer and summary of French pottery imported into Scotland c 1150 to c 1650: a ceramic contribution to Scotland's economic history'. A CD ROM in *Tayside and Fife Archaeological Journal*, 12, 117–8.

- Haggarty, G & Alexander, D 1998 'The pottery', in D Alexander, N Q Bogden & J Grounsell 'A Late Medieval hall-house at Uttershill Castle, Penicuik, Midlothian', *Proceedings of the Society of Antiquaries Scotland* 128, 1017–1046.
- Haggarty, G & Will, R 1996 'The pottery', in J H Lewis 'Excavations at St Andrews Castle 1988–90', *Proceedings Society Antiquaries Scotland* 126, 648–669.
- Haggarty, G & Hall W 2010 "'Throw some more fuel on the fire": The stove tiles of Medieval Scotland', in K De Groote; D Tys and M Pieters (eds) *Exchanging Medieval Material Culture Studies on Archaeology and History Presented to Frans Verhaeghe*, *Relicta Monografieën 4 Archeologie, Monumenten- en Landschapsonderzoek in Vlaanderen*, 67–74.
- Haggarty, G; Hall, D & Chenery, S 2011 'The Scottish Red Ware project', *Medieval Ceramics Monogr Ser*, Vol. 5.
- Hall, D W 1997 '134 and 120–4 Market Street', in M J Rains and D W Hall (eds) *Excavations in St Andrews*. Tayside Fife Archaeol Comm Monogr 1, 26–30. Glenrothes.
- Hall, D W 1997a 'The pottery', in M J Rains & D W Hall (eds) *Excavations in St Andrews 1980–89*. Tayside Fife Archaeol Comm Monogr 1, 40–63. Glenrothes.
- Hall, D W; MacDonald ADS; Perry, D R & Terry, J 1998 'The archaeology of Elgin: excavations on Ladyhill and in the High Street, with an overview of the archaeology of the burgh', *Proc Soc Antiq Scot*, 128, 753–829.
- Hamilton-Dyer, S; McCormick, F; Murray, H K and Murray, J C 1993 'The bone assemblage and animal husbandry', in 'Rattray Castle, Aberdeenshire', *Medieval Archaeology* 37, 203–205.
- Hanf, M 1983 *The Arable Weeds of Europe*. Hadleigh, Suffolk.
- Henderson, D 2002 'The faunal remains', 408–12 in S Stronach 'The Medieval development of South Leith and the creation of Rotten Row', *Proceedings Society Antiquaries Scotland* 132, 383–423.
- Hillson, S 1986 *Teeth*. Cambridge Manuals in Archaeology. Cambridge University Press, Cambridge.
- Historic Scotland 2008 [http://www.historic-scotland.gov.uk/index/properties/properties\\_sites\\_detail.htm?propertyID=PL\\_125](http://www.historic-scotland.gov.uk/index/properties/properties_sites_detail.htm?propertyID=PL_125), accessed 28/03/08.
- Holdsworth, P 1987 *Excavations in the Medieval Burgh of Perth 1979–1981*. Edinburgh (=Soc Antiq Scot Monogr Ser, 5).
- Holmes, N M 1975 'Excavations within the Tron Kirk Edinburgh, 1974', *Post Medieval Archaeology* 9, 137–163.
- Holmes, N M 1986 'Excavations within the Tron Kirk, Edinburgh: A post-script', *Post Medieval Archaeology* 20, 297–302.
- Holmes, N M 1988 'Canongate Tolbooth, cellar of Tolbooth prison', *Discovery Excav Scot*, 18.
- HAPT (Holyrood Archaeology Project Team) 2008 *Scotland's Parliament and the Canongate: Archaeology and History*. Edinburgh: Soc Antiq Scot Monogr Ser.
- Horton, M C; Higgins, D A and Oswald, A 1987 'Clay pipes from the Scottish Darien colony (1698–1700)', in P J Davey (ed), 239–252.
- Hurst, J G 1974 'Sixteenth- and seventeenth-century imported pottery from the Saintonge', in I Evison; H Hodges and J G Hurst (eds) *Medieval pottery from excavations: studies presented to Gerald Clough Dunning*. London.
- Hurst, J G; Neal, D S and van Beuningen, H J E 1986 'Pottery produced and traded in north-west Europe 1350–1650', *Rotterdam Papers*, VI, Rotterdam.
- Jones, R; Will, D; Haggarty, G & Hall, D 2006 'Sourcing Scottish White Gritty Ware', *Medieval Ceramics* 26–7, 45–83.
- Laing, L R 1973 'Cooking pots and the origins of the Scottish Medieval pottery industry', *Archaeological Journal*, 130, 183–216.
- MacKay, J 1879 *History of the Burgh of Canongate*. Edinburgh.
- Mair, C 1988 *Mercat Cross and Tolbooth*. John Donald, Edinburgh.
- Martin, C J M 1987 'A group of pipes from Mid Shore, Pittenweem, Fife', in P J Davey (ed) 1985, 183–209.
- Maxwell, R 1997 'Copper-alloy objects', in M J Rains and D W Hall (eds) *Excavations in St Andrews*. Tayside Fife Archaeol Comm Monogr 1, 64–74. Glenrothes.
- Meulen, J van der; Brinkerink, J P and Hout, P von 1992 *Tabakspijpenijverheid in Gorinchem*. Pijpelogische Kring Nederland, Leiden.
- NSA 1845 *The New Statistical Account of Scotland*. Vol 1, Edinburghshire.
- Moloney, C & Coleman R 1997 'The development of a Medieval street frontage: evidence from excavations at 80–86 High Street, Perth', *Proceedings Society Antiquaries Scotland* 126, 707–782.
- O'Connor, T P 1988 'Bones from the General Accident Site, Tanner Row', in P V Addyman (ed) *The Archaeology of York: The Animal Bones 15/2*. CBA, York.
- Payne S 1969 'A metrical distinction between sheep and goat metacarpals', in P Ucko and G W Dimbleby (eds) *The Domestication and Exploitation of Plants and Animals*, 295–305. Duckworth, London.
- Payne, S 1973 'Kill-off patterns in sheep and goats', *Anatolian Studies* 23, 281–303.
- Pryde, G S 1965 *The burghs of Scotland*. London.
- Quail, G 1982 'Maxwell's Pig House, Calton', in 'Four Old Glasgow Potteries', *Glasgow Archaeological Society Occasional Paper No. 1*, 1–3.
- Rains, M J and Hall, D W 1997 *Excavations in St Andrews 1980–89: A Decade of Archaeology in a Historic Scottish Burgh*. Glenrothes (= Tayside and Fife Archaeol Committee Monogr, 1).
- RAHMS 1951 *The Royal Commission on the Ancient and Historic Monuments of Scotland. An Inventory of the ancient and historical*

- monuments of the City of Edinburgh with the thirteenth report of the Commission.* Edinburgh.
- Ross, L & Clark, P R 1997 'Cinema House', in M J Rains & D W Hall (eds) *Excavations in St Andrews*. Tayside Fife Archaeol Comm Monogr 1, 21–26. Glenrothes.
- Sermon, R & Cox, A 1996 'Excavation at Meal Vennel', in A Cox 'Backland activities in Medieval Perth: excavations at Meal Vennel and Scott Street', *Proceedings Society Antiquaries Scotland* 126, 733–821.
- Sigleo, A C 1978 'Organic geochemistry of silicified wood, Petrified Forest National Park, Arizona', *Geochimica et Cosmochimica Acta* 42, 1397–1405.
- Sillen, A 1989 'Diagenesis of the inorganic phase of cortical bone', in T Douglas Price (ed) *The Chemistry of Prehistoric Human Bone*. Cambridge University Press, Cambridge.
- Silver, I A 1969 'The ageing of domestic animals', in D R Brothwell and E S Higgs (eds) *Science in Archaeology*. Thames and Hudson, London.
- Simpson, A T; Stevenson, S & Holmes, N 1981 *Historic Edinburgh, Canongate & Leith: the archaeological implications of development*. Scottish Burgh Survey.
- Smith, C 1999 'Dogs, cats and horses in the Scottish Medieval town', *Proceedings Society Antiquaries Scotland* 128, 859–86.
- Smith, C and Hodgson, G W I 1987 'The animal bone', in P Holdsworth (ed), 196–199.
- Spearman, R M 1982 'Excavations at 17–21 Castle Street, Forfar', *Proceedings Society Antiquaries Scotland* 112, 455–464.
- Spearman, R M 1987 'Metalworking evidence', in P Holdsworth (ed), 157–8.
- Spearman, R M 1987a '29–30 South Methven Street', in P Holdsworth (ed), 47–58.
- Spearman, R M 1988 *Industrialization and urbanization in Medieval Scotland: The Material Evidence*. Unpub PhD thesis. Univ of Glasgow.
- Spearman, R M 1997 'The smithy and metalworking debris from Mills Mount', in S T Driscoll and P A Yeoman (eds), 164–8.
- Toolis, R & Cavanagh C 2002 'The burgh ditch of Annan: an excavation at Butts Street, Annan', *Transactions Dumfriesshire & Galloway Natural History & Antiquarian Society* 76, 141–158.
- Watkins, G 1993 'The pottery', in D Evans (ed) *Excavations in Hull 1975–76*, 75–145. *East Riding Archaeologist* 4, *Hull Old Town Report Series* No 2.
- Withrington, D J & Grant, I 1975 (eds) *The Statistical Account of Scotland: The Lothians*, vol II. Wakefield.
- Wood, M. 1956 *Book of Records of the Ancient Privileges of the Canongate*. Edinburgh.
- Yeoman, P 1995 *Medieval Scotland*. Historic Scotland/Batsford, London.