

Excavations at Kinneil fortlet on the Antonine Wall, 1980–1

Geoff B Bailey* & John Cannel†

with contributions by I Hodgson, A T Croom, C Smith,
P V Webster & G Webster

ABSTRACT

Excavation at Kinneil recorded a long-axis fortlet measuring 18.5 m west/east by 21.5 m north/south internally, attached to and contemporary with the Antonine Wall. A cobbled road, flanked by rectangular wooden buildings, ran between the north and south gateways. The ramparts were protected by a single small ditch, with the main Antonine Ditch to the north. Within the period of the Roman occupation the site was remodelled with the north gate being permanently sealed, and the ditch to the north carried across the causeway. The site then seems to have functioned as a turret or observation tower.

The work was funded by the Manpower Services Commission and co-ordinated by Falkirk Museums.

INTRODUCTION

It has long been thought that the remains of an Antonine Wall fort lie somewhere in the vicinity of Kinneil House (evidence summarized in Macdonald 1934, 191–2). Central to this argument is the belief that such a fort was needed to fill the 4.5 mile (7.2 km) gap between the forts at Carriden to the east, and Inveravon to the west. In the 1970s fieldwalking by members of the Cumbernauld Historical Society produced Roman pottery from the fields to the west of Kinneil House and focused attention on a small knoll 500 m west of the house. Subsequent trial excavations in 1978–80 (Keppie & Walker 1981) proved the existence of a fortlet at this location, attached to the Antonine Wall (illus 1). This work established the outlines of the rampart and the ditch.

In 1980, as part of a broad plan to make the history and ecology of Kinneil Estate more accessible to visitors, it was decided to excavate the site more fully and to consolidate the remains. To this end a Special Temporary Employment Programme (STEP) scheme was established by the Manpower Services Commission and Falkirk District Council (Dept of Libraries & Museums), and work took place on the site between October 1980 and June 1981. This excavation was directed by J Cannel and monitored by F Murray of the Falkirk Museum Service. An interim report was produced by J Cannel at that time, but it fell to the museum's new archaeologist, G Bailey, to prepare that account for publication. At this time it was found that the palaeoenvironmental samples taken during

* Falkirk Museum, Callendar House, Callendar Park, Falkirk FK1 1YR

† 6 Bongate View, Jedburgh TD8 6DS

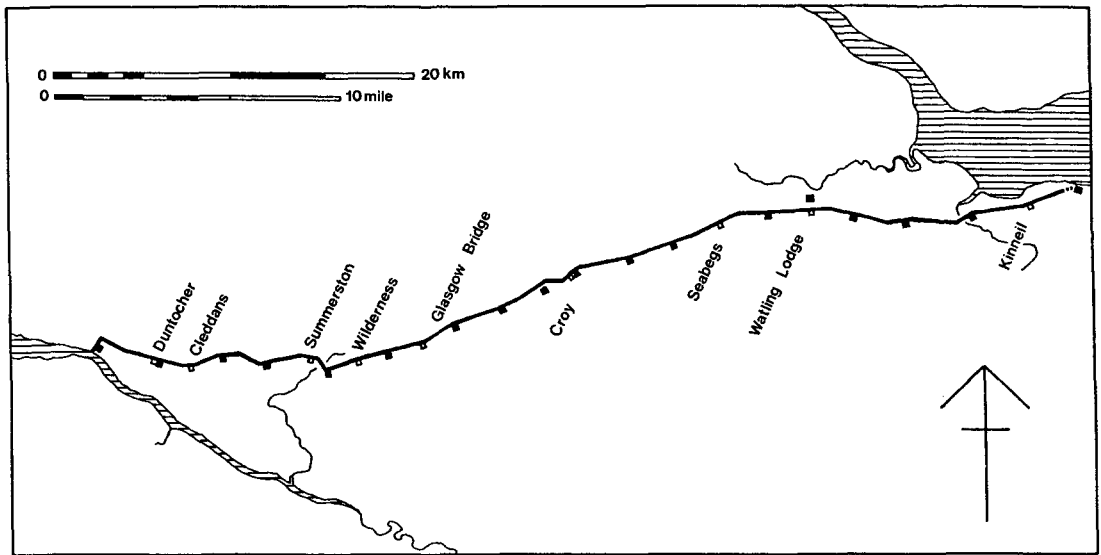

ILLUS 1 The location of Kinneil fortlet along the Antonine Wall; the positions of the other known fortlets are also shown

the excavation had dried out in storage and become contaminated. Consequently, no analyses of these appears in this report.

Originally it was intended to clear the whole area of the fortlet and surrounding ditches by hand. This was, however, unrealistic, and even with a limited amount of mechanical help, exploration of the ditches was confined to a number of sample trenches.

The excavation confirmed the previous findings of fieldwalking and trial excavation, and exposed a long-axis fortlet of slightly irregular shape, measuring 18.5 m west/east by 21.5 m north/south internally, attached to and contemporary with the Antonine Wall. A cobbled road, flanked by rectangular wooden buildings, ran between the north and south gateways. The ramparts were protected by a single small ditch, with the main Antonine Ditch running uninterrupted past the north gate.

In general, the site was badly preserved, the main culprit apparently being deep late medieval rig and furrow cultivation. Fortunately the area around the north gate survived sufficiently for two short phases of use to be identified. Interpretative plans of the fortlet (illus 28 & 29) have been projected from its surviving fragments and from the position of the south gate.

EXCAVATION RESULTS

PHASE I: THE ANTONINE WALL AND CONSTRUCTION OF THE FORTLET

Earthwork structures

The whole of the area of the fortlet was systematically stripped of topsoil, including a 30 m length of the Antonine Wall along the front of the fortlet. A further 11 m of the Wall's south kerb only was exposed to the east of this (see illus 3). Throughout the excavated length the rampart was of normal construction for this sector, consisting of a foundation of dressed kerbstones infilled with rubble, set directly onto the natural clay and gravel and surmounted by a superstructure of red-brown

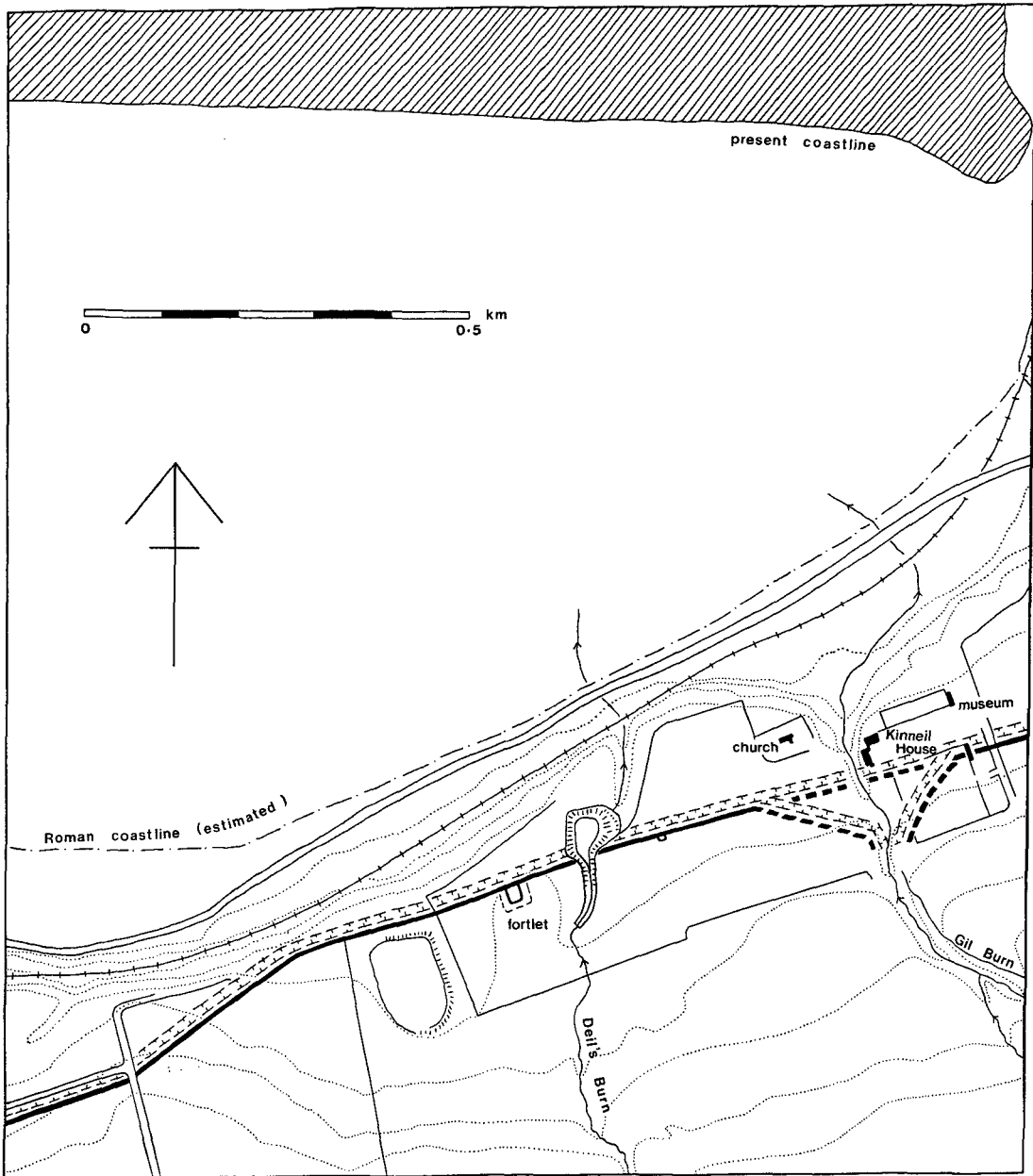

ILLUS 2 The local topography of Kinneil (Based on the Ordnance Survey map © Crown Copyright)

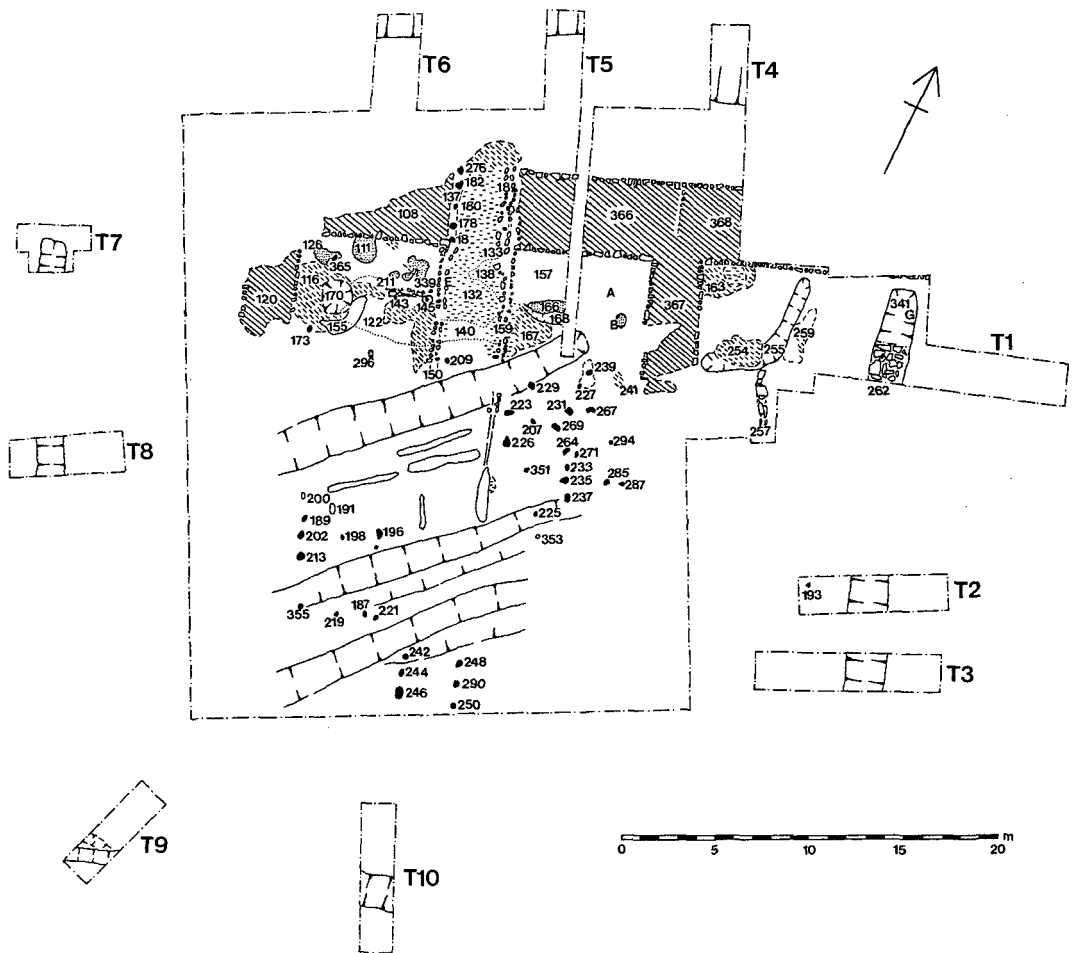

ILLUS 3 General site plan giving the feature numbers referred to in the text. Find spots shown for A, harness strap junction; B, spearhead; E, coin; G, axe-head

clay loam revetted with turf or clay cheeks (discussion and full references in Keppie 1974, 156–61). West of the fortlet's north gateway, the north kerb had been completely removed, though the south kerb survived over a length of 7 m. Farther west, no trace of the Wall base was found, neither were there any remains of its junction with the west fortlet rampart. To the east of the gateway, however, the wall base was preserved intact.

The Wall varied from 4.2 m to 4.3 m in width over the excavated length. Individual kerbstones, though widely varied in size, averaged 0.4 m long at the exposed face, sitting 0.2 m proud of the subsoil. West of the north gate, the rubble fill of the Wall base comprised friable angular sandstone slabs measuring as much as 0.5 m across. East of the gate the foundation consisted of variable boulders of rather smaller size. Small angular stone chips were present in the Wall base. From about 0.5 m east of the gate to the east limit of the excavation, the rubble fill became smaller and more angular, while a larger number of small chippings filled the interstices.



ILLUS 4 Demarcation line in the Wall base at the north-east corner of the fortlet, looking south

There was no break in the stonework between the Antonine Wall and the east rampart of the fortlet. However, within the base of the Wall, there was an alignment of stones running at right angles from the north kerb towards the centre of the fortlet rampart on line with the south kerb of the Antonine Wall (illus 4). The stones were arranged to form a fair or regular face along their western edge.

Survival of the earth and turf or clay superstructure of the Wall was fragmentary. West of the north gate a few spreads of slumped and disturbed revetting material were found, and only slight traces of the clay-loam fill remained between the basal stones. East of the gate, up to 0.4 m of superstructure survived, though slumping and disturbance had been severe. The kerbs were overlain by a band of buff-coloured clay, 0.35 m wide, disturbed by animal action. Under such conditions it was difficult to distinguish between turf or clay here, and the cheeks or facings may have been of

either material. The cheeks did not appear to respect the internal stone alignment noted above, neither was there any apparent boundary in the superstructure between the Wall and the east rampart of the fortlet. Several patches of burnt material were noted within the slumped material.

Finds sealed by the collapsed superstructure of the Wall included quantities of Black-burnished ware and two amphora rims from beyond the north kerb. A quantity of butchered cattle bone and a decorated bronze harness strap junction were found in the disturbed material in the interior.

For the most part, the fortlet ramparts had completely disappeared. To the west, a mere 2 m of rampart base remained, but its junction with the Antonine Wall had been obliterated by later plough damage. A 7 m length of the east rampart survived southwards from the Wall, save for a gap where a deep furrow had been driven through. There was no surviving trace of the south rampart. The ramparts were 3 m wide, and were apparently constructed in the same way as the Wall. No cheek material remained *in situ* over the west rampart, but a few fragmentary patches of clay lay where they had collapsed beyond the kerbstones. The rubble foundation of the east rampart again contained a number of tiny stone chips packed around larger rocks. The superstructure reached a maximum height of 0.2 m at its junction with the Antonine Wall, diminishing rapidly to the south. Again collapsed material had spread out to either side of the rampart.

Small patches of laid turf were noted in the north-west corner, north of Context 126. Together with Post-hole 365 and an area of burnt earth and stone (Context 126) these will be considered as possible remnants of turfwork for a rampart stair, in the discussion (below).

The fortlet ditch

During trial trenching of the site in 1978–80, Keppie & Walker (1981) noted two small parallel ditches beyond the fortlet ramparts. In the course of the present excavation seven trenches were placed at intervals across the projected line of these ditches, though only one (Trench 1) was extended beyond the putative second or outer ditch. Trenches 2 and 3 should also have clipped this feature but although a thorough search was made for it, only a single ditch was found.

The berm between the ditch and the fortlet rampart averaged 9 m in width, reaching an estimated maximum of 13 m at the two southern corners. No causeway was found in Trench 10 opposite the south gate to carry the road from the fortlet to join the Military Way some distance to the south (Macdonald 1934, 106). The ditch extended to within 0.5 m of the Antonine Wall on both the east and west sides, where it ended in roughly squared-off terminals. Although in Trenches 9 and 10 the ditch had been severely truncated, in less disturbed areas it reached its maximum size of 2 m across by 1 m deep. The ditch was clearly of one phase, with no sign of recutting in any of the trenches (illus 5). The profile was generally V-shaped, with a slightly rounded bottom. Trench 8 showed a slight variation with a U-shaped trough cut into the bottom, 0.45 m wide by 0.2 m deep. No associated bank was found in the vicinity to represent the upcast earth.

In the trenches where plough-truncation of the ditch was less severe, the edges remained quite sharp and distinct, suggesting that only a small amount of weathering took place while the ditch was open. In Trenches 1, 9 and 10 there was no obvious natural silting, while the primary fill in the remaining four trenches consisted of naturally deposited material, just 0.1 m in depth. Above this primary silting the ditch fills consisted of slight variations of a red-brown/orange silty clay with patches of blue-grey clay.

All the pottery recovered from the ditch sections came from the uppermost fill of Trench 7, at the western terminal. The only other find was an axe-head recovered from the very bottom of the ditch at the eastern terminal.

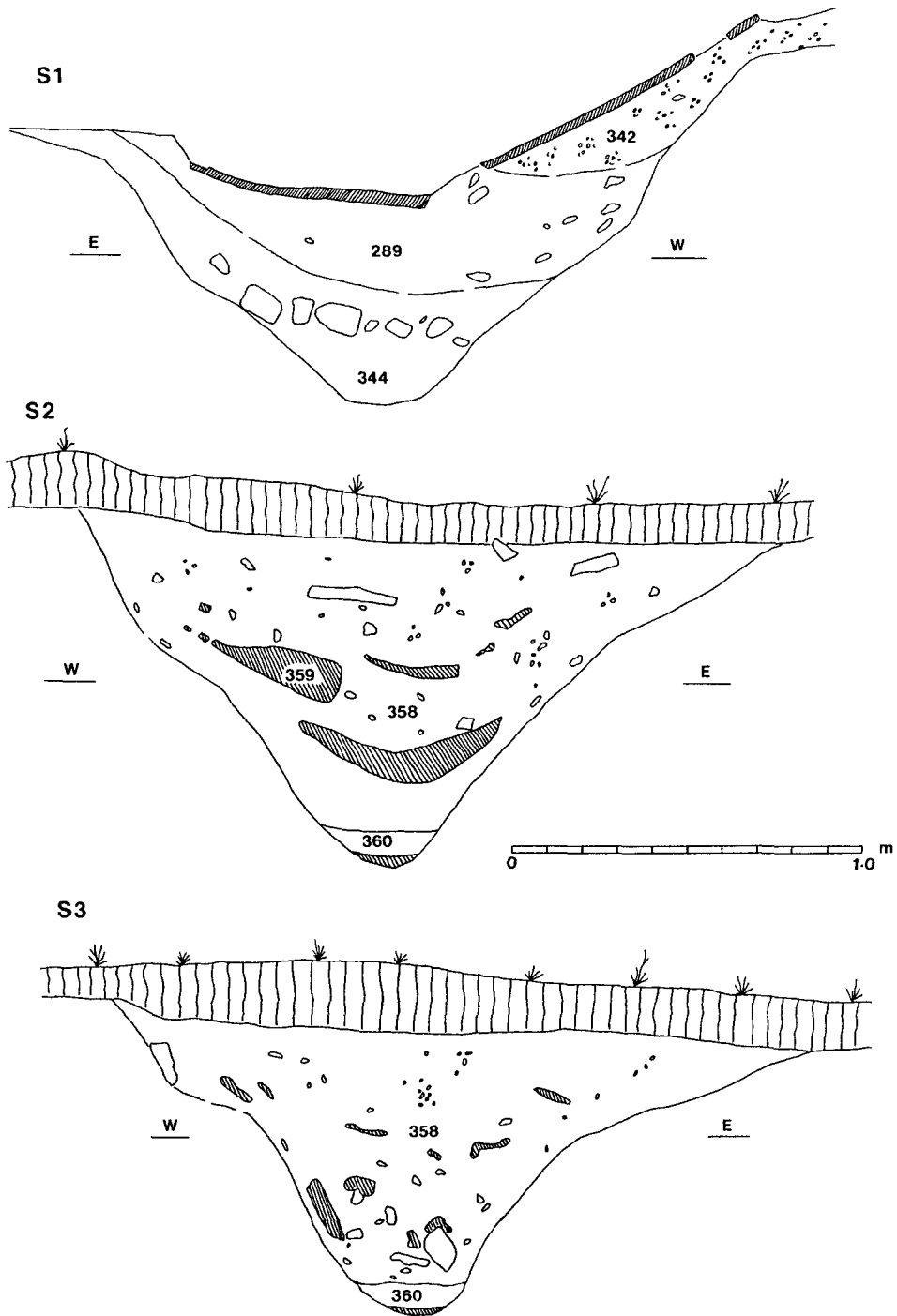

ILLUS 5 Sections across the fortlet ditch – Section 1: 289 dirty grey clay with occasional light brown mottling; 342 light brown clay-silt; 344 pale grey silty clay; Section 2: 358 brown-orange sandy clay; 359 pale grey lenses of silty clay; 360 dirty grey & orange clayey silt; Section 3: As section 2

The Antonine Ditch

Three small trenches were placed across the south lip of the Antonine Ditch. None of these trenches was fully bottomed, excavation stopping when the position of the Ditch edge had been confirmed in each case; neither was there time within the excavation schedule to examine the north edge of the Ditch, or the earth mound beyond. However, the Ditch and slight traces of the mound can be seen as a slight dip and rise running east from the fortlet. There is no sign of a causeway across the Ditch associated with the fortlet's north gateway.

The berm between the Wall and Ditch varied from a narrow 4 m in the east trench, to 8.4 m in the west trench. Similarly, as the berm broadens so the Ditch narrows. Based on surface observation, the width of 11 m opposite the east rampart narrows to 6 m opposite the west rampart. This variation is within the limits set by known Ditch widths in the immediate locality: at Dean House to the east a width of 5.5 m was recorded, while at Summerhouse Park to the west the width was 10.7 m (Keppie 1974).

The entrances and interior of the fortlet

The northern entrance of the fortlet was 3 m wide and gave access to the interior via a cobbled road (illus 6). A line of five post-holes was excavated along the west side of the entrance. They were placed in a shallow setting-out trench (cf Wilderness Plantation – Wilkes 1974, 55). All but the central one were of similar size, c 0.35 m diameter by 0.4 m deep; the pits were spaced at intervals of 0.8 m. The central post-hole was rather smaller, and was separated from those on either side by a distance of just over 1 m. No trace of posts or packing was found, suggesting deliberate removal of the posts, and slumped rampart material was present in the upper fills of several of the post-holes.

Along the east side of the entrance, only the bottom 0.05 m of four post-holes could be tentatively identified as they had mostly been cut away by the insertion of a later culvert (Phase 2). Their relative positions matched those of the post-holes on the western side and it would seem that they were part of the original gate/tower. However, to the east of the later culvert was a gully which may also represent a setting-out trench for this structure. Alternatively, it might be part of the construction trench for the culvert.

Unfortunately, the gateway through the south rampart was particularly badly preserved. All that remained were two lines of three post-holes, at 0.9 m intervals forming an entrance passage 3 m wide. The post-holes were of similar size to those in the north entrance. One, in particular contained a relatively undisturbed packing of boulders and indicated that it had held a post of c 0.15 m diameter.

The cobbled road through the northern entrance was 2.0 m wide, and was formed mainly of round cobbles between 0.1 and 0.2 m in diameter, packed around with gravel to form a hard, fairly smooth surface. The cobbles had been pressed directly into the clay subsoil and where least disturbed the road reached a thickness of just over 0.1 m. There were no signs of wear or repair on the road surface. There was no trace of the road north of the Antonine Wall, as truncation here had been particularly severe. As it entered the fortlet through the north gate the road broadened to just under 3 m wide. Although no trace remained farther south than 5 m inside the fortlet it seems likely that it had originally continued through the interior and exited through the south gate.

Inside the fortlet the road was flanked by open drains. These were laid in shallow trenches 0.7 m wide by a maximum of 0.2 m deep. Their sides and bases were made up of rounded boulders forming a channel 0.2 m wide by 0.15 m deep. Where undisturbed, their fills consisted of silty clay with very few small pebbles. It must be supposed that as with the road, both drains continued through the south entrance. It is worth noting that from c 5 m inside the north entrance, drainage would have



ILLUS 6 The north gateway looking north-east. The road through the fortlet runs almost horizontally across the photograph. The north rampart passes from the centre left to the top right

been towards the south. As originally built, the north ends of both drains butted directly against the Antonine Wall base, rather than being channelled through the entrance, or culverted through the Wall. They were later modified by diverting the flow of water into new channels which passed through the north gateway (illus 9; Phase 2, below).

Main buildings

The remains of wooden buildings lay either side of the road. The two main structures were apparently orientated north/south, occupying much of the interior. These will be described, below, as Building 1 (west of the road) and Building 2 (east of the road).

Evidence for both buildings derived largely from post-holes, their restricted distribution reflecting later activity on the site: several of the medieval furrows were deeper than the average depth of the post-holes, and clearly many had disappeared altogether. The post-holes were similar in size and types of fill, and it is possible to discuss them briefly together. Where they survived, the post-holes were roughly circular in plan, averaging 0.35 m diameter with a depth of c 0.2 m. Stone packing was present in several, including Contexts 196, 202, 213, 219 and 221 (all Building 1), and Contexts 207, 233 and 235 (Building 2). Most of the packing had been disturbed but in some, such

as Context 196, it was more or less *in situ*, suggesting that the posts were c 0.1 m diameter, though it was not possible to judge their shape. The soil fill of all the post-holes was a uniform loamy clay. Together with the absence of any traces of wood, and the disturbed condition of the packing, it seems that all the posts were deliberately removed, and the area levelled.

The shallow oval depressions associated with Building 2, notably Contexts 223, 226 and 237, were again fairly uniform in size, measuring approximately 0.4 m by 0.25 m wide by 0.1 m deep, and were filled with a featureless clay loam similar to that in the post-holes. They probably signify post pads, rather than deeply dug holes, though there is no indication that they had any different function.

Building 1 measured c 15 m north/south by 4.1 m east/west. The evidence for this structure was largely concentrated in the south-west corner of the fortlet, where eight post-holes (Contexts 202, 198, 196, 221, 187, 219, 355 and 213) defined the southern wall angles and enclosed an approximately rectangular area 4.0 m north/south by 4.1 m east/west. Following the west wall northwards, Post-holes 189, 200 and 9 m further north, Context 173, are all aligned. The northern limit of the building is difficult to determine, but appears to be bounded to the north by rough metalling (Contexts 116 & 148). These gravel spreads are probably external surfaces servicing the area around a well/latrine (see below). Internal partitions are suggested by Post-holes 198 and 296. Due to the poor state of preservation away from the Antonine Wall it is not possible to be certain how far south the cobbles bordering the west side of the west drain extended. It is likely that they fronted the building along its entire length and that the drain acted as an eaves drip.

As with Building 1, Building 2, occupying the east side of the fortlet, was represented by a localized spread of post-holes, surviving only where the later rig-and-furrow cultivation had been less severe in its effects. Again the back wall of the building seems to have been set about 1.0 m in from the inner face of the rampart, here represented by Post-holes 241, 294 and 285/287. Similarly, the front or west wall lay 2.0 m from the drain (Context 159), consisting of Post-holes 229, 207 and 351. Two shallow oval slots, Contexts 223 and 226, may be the structural remains of a covered veranda fronting this building, or of a porch. The south limit of the building has been completely lost, but it is reasonable to assume it lay on line with that of Building 1, that is c 1.5 m from the south rampart. To the north it was also bounded by an area of rough paving (Context 167) giving an overall length in the region of 15 m. An internal north/south division may be indicated by Post-holes 237 and 235, supplemented by small Post-holes 231, 264 and 233.

The disturbed and vestigial condition of the post-holes, and the lack of additional material, presents difficulties in trying to interpret the form of the buildings. The shallowness of the post-holes, allowing for subsequent truncation, suggests a fairly lightweight wooden building with an equally lightweight roof. No traces of building material were identified. It may be that the posts formed a framework onto which suitable weatherproofed wattle panels were attached, with a roof either of thatch or wooden shingles (no fragments of slate or tile were found during the excavation).

Lean-to buildings

On the north side of the gravel spread, or metallated area (Context 148) which indicated the north gable of Building 1, lay an isolated length of wall foundation (Context 143) 2.5 m in length (illus 7). This consisted of small flat slabs with a line of pitched ones forming a kerb on the north side. At the west end was a stone-packed post-hole (Context 211) with a corresponding one at the east (Context 145). These features may represent the front wall of a lean-to structure appended on the south or inner face of the Antonine Rampart. Context 339 would then be part of the return wall along the east side. Under the south wall of this structure was a substantial spread of charcoal



ILLUS 7 The sill foundation (Context 143) of the lean-to structure, looking east to the west roadside drain; the post-hole in the foreground is Context 211

(Contexts 146 & 147), and between it and the rampart the earth had been oxidized by heat. Whilst these would appear to predate the structure and thus to be associated with the original clearance and preparation of the site, their distribution reflects the spatial arrangement of the suggested structure so well that it is possible that the two are indeed associated. Perhaps the burning represents an earlier version of the shelter. The small patch of scorched soil to the west (Context 111) may also be part of this activity.

In the north-east corner of the fortlet was an extensive patch of gleyed clay (Context 158). It was about 0.15 m deep and was capped with a thin gravel layer (Context 157) measuring 3 m east/west by 2 m north/south. It was bordered on the south by a strip of gravel (Context 166) and a narrow slot (Context 168). It is possible that this may have been the footings for a turf-built rampart stair giving access to the wall heads, but it is more likely that these features represent the floor, front wall and eaves drip of a second shelter or lean-to, appended on the rampart at the east side of the gateway, in a corresponding position to the one described above at the opposite or west side.

The welllatrine pit

In the north-west corner of the fortlet was a large, deep circular pit, (Context 170). It was 2 m wide at the top, rapidly tapering to a shaft 1 m wide, with a total depth of 3 m (illus 8). The three primary fills, occupying the bottom 0.6 m, contained a large number of small twigs, perhaps wattle fragments,

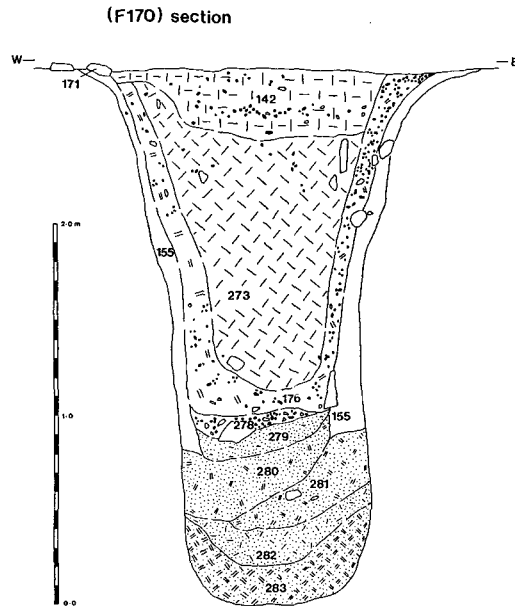

ILLUS 8 Section of Context 170, the well/latrine pit

a quantity of worn and broken leather sandals, and most of a broken Black-burnished ware cooking pot. In addition, a wooden wedge and a small stopper for a bottle or jar were recovered. Above these waterlogged organic layers the remainder of the fills comprised clayey deposits mixed with variable amounts of gravel, small stones and pockets of loamy soil, probably the result of deliberate back-filling.

PHASE II: MODIFICATION OF THE FORTLET

The interior and north gateway

At some time in the Roman period substantial alterations were carried out to the north gateway, and indeed it may be that it went out of use. At the east side of the entrance, a well-built stone-capped culvert (Context 133) was attached to the north end of Drain 159, to run out through the north gateway. The culvert was of a box drain type, with only a few capstones surviving, forming a channel 0.25 m square in section; it was filled with a stone-free homogenous silty clay. No base slabs were incorporated, the channel bottoming directly onto subsoil.

The insertion of the culvert obliterated all but the very bottom of the east side entrance post-holes, so that the gateway must have been completely dismantled at this time. The culvert also cut into the eastern edge of the road (Context 132) and at the same time created some disturbance to the end kerb of the Antonine Wall, which may have supplied some stones for re-use in its construction. As part of this operation a small gully was created on the line of the old kerb, that is on the east side of the new culvert, which in places was deeper than the bottom of the post-holes. Whilst this may simply have been part of the construction trench for the culvert the new drain (illus 9) was clearly offset to avoid this feature, and it is much more likely to have had some significant structural purpose such as the footing trench or foundation slot of a new gate tower.

A small hearth lay directly over the road in the middle of the entrance, sealing a quantity of



ILLUS 9 The east drain alongside the road through the fortlet looking north; the change of alignment occurs at the north gateway

amphora sherds on the road surface. The burning was in turn overlain by patches of slumped rampart superstructure, which also sealed the culvert.

Overlying earlier features in the northern half of the interior was an extensive though intermittently surviving layer of rough cobbles and uneven flagstones (Contexts 117 & 122), capped with gravel (Context 138), together reaching a thickness of 0.15 m. This surface would have provided convenient access to the northern rampart and some hard standing nearby. Its distribution suggests that the lean-to shelters may have been retained. Between this new metallised surface and the horizon containing the internal buildings was a band of sterile orange-brown clay loam, varying in thickness from 0.05 m to 0.15 m.

External features

Outside the fortlet, in the angle formed by the junction of the east rampart and the Antonine Wall, was a spread of cobbles and gravel (illus 10) Context 162/163). Measuring 2.3 m east/west by 1.3



ILLUS 10 The stone platform (Context 163) outside the east fortlet rampart at its junction with the Antonine Wall, looking west

m north/south, and 0.2 m high, this low platform was enclosed on its south and east sides by a small curving ditch (Context 255), which had a total length of 8 m. Its north and west terminals respected the adjacent earthworks, stopping 0.2 m short of the Antonine Wall and the fortlet rampart, so that it clearly post-dated the construction of these structures. The ditch, with a gentle V-shaped profile, was 0.7 m wide by 0.45 m deep, and appeared to have filled up largely as a result of natural silting, the fills consisting of layers of fine silty loam with frequent small charcoal inclusions (illus 11). There was nothing to suggest an associated palisade of any sort. Towards its west end the ditch was sealed by a dump of rounded boulders (Context 254) creating a causeway.

The remains of a box drain (Context 257) ran into the ditch from the south. This culvert was of very similar construction to Context 133, the later work in the north gateway; it had roughly squared sides and capstones, no stone bottom, and was similar in size. Unfortunately the limits of the excavation and increasingly severe rig-and-furrow damage meant that its probable southern extent could not be traced.

Outside Ditch 255 lay a substantial, though disturbed, hearth (Context 260) surrounded by an extensive spread of ash (Context 259), up to 2.5 m across and 0.1 m thick. It is likely that many of the charcoal fragments noted in the ditch fill originated from the hearth.

Just within the eastern terminal of the fortlet ditch (illus 12) in Trench 1 the upper fill was sealed by flagging formed of large angular sandstone slabs up to 0.7 m across by 0.04 m thick. The slabs had slumped into their present position as the fill settled. This crude causeway (Context 262)

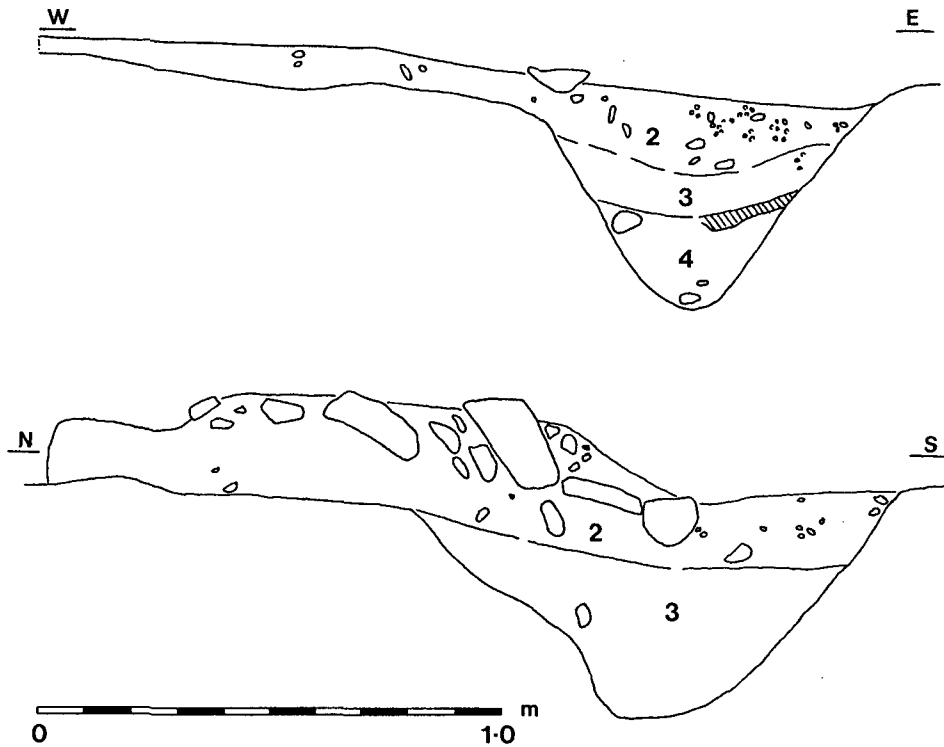

ILLUS 11 Sections across the curving ditch (Context 255), with stone feature (Context 254) above; 2: grey-brown sandy silt with charcoal flecks; 3: brown-grey clay silt with some charcoal flecks; 4: brown silty clay with charcoal flecks

could post-date the occupation of the fortlet, but it is more likely that it is related to the adjacent secondary fortlet features noted above, presumably as an access across the backfilled ditch.

PHASE III: RIG AND FURROW

Much of the southern part of the fortlet had been damaged by a series of wide shallow ditches or gulleys running diagonally across the area from south-west to north-east. Their northern ends terminated short of the Antonine Wall, presumably because this still represented a substantial impediment to their progress. They were approximately 3.9 m apart, centre to centre, and contained late medieval and post-medieval pottery. They evidently formed part of the rig and furrow cultivation associated with the infield of the deserted village of Kinneil which lay adjacent to the old parish church at the east end of the meadow.

THE FINDS

All the finds from the excavation have been deposited with Falkirk Museum under the general accession number 1983-1.

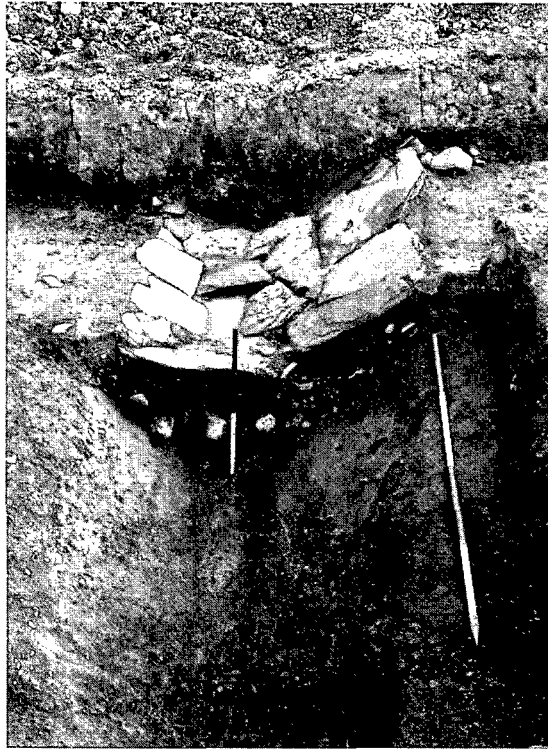

ILLUS 12 Section across the east fortlet ditch looking south; the stone paved causeway has sunk into the unconsolidated fill

HARNESS STRAP JUNCTION

Graham Webster

This fine bronze (illus 13 & 14) has two projecting rectangular loops attached to the back, one of which survives. The front is beautifully decorated with a debased S-scroll and two domed mounts, forming a leaf-like pattern. There are two projecting panels to mask the loops at top and bottom, each with smaller domed mounts; the whole has been cast and later tooled with panels incised in the rectangular projections. The mount was a decorative junction for two strap or trace terminals which were attached to the loops. Alternatively, a single trace could have run through the loops and another could have passed at right angles between the mount and the first trace and, in this case, the function would have been to hold the two crossing traces in their relative positions. Another possibility is that the lunate openings could have held trace terminals, but this would have obscured the decoration and there appears to be no indication of wear on the metal; this would not be considered except for the later development of these parts of the mount as rings (as in the Fremington Hagg and Carlisle examples, see below).

These decorative pieces often exhibit fine Celtic craftsmanship, but Roman taste transformed the freedom of the Celtic scroll motif into a debased and standardized symmetry. This tendency is already visible in the Kinneil object and more obviously in other examples. The mounts from Garden

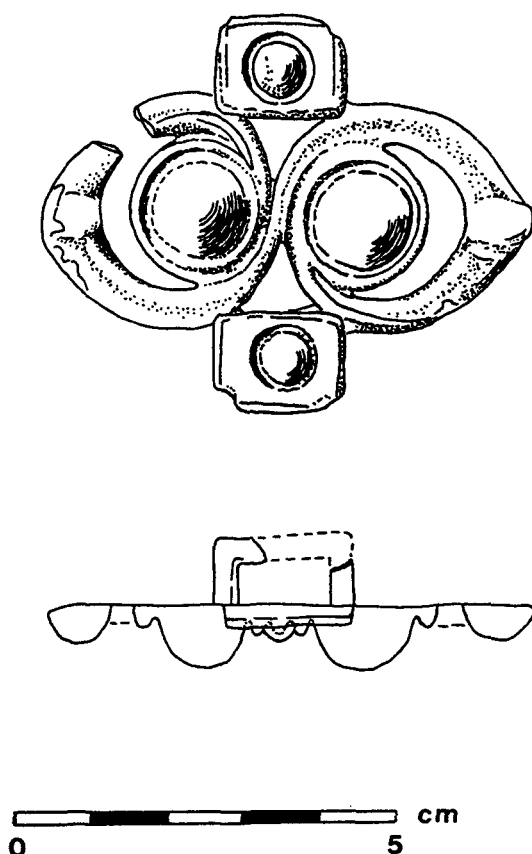

ILLUS 13 The bronze harness strap junction

Hill, Sussex (Money 1977, fig 5), and the Seven Sisters hoard (Davies & Spratling 1976) have the S motif, although the latter is a highly decorated piece, rich in enamel inlay. There are other examples which show a total absence of any Celtic influence, two of them from Fremington Hagg (Webster 1971, no 78) and Carlisle (MacGregor 1976, no 19), which as stated above, have plain ring-loops. Much smaller and more simplified versions come from Newstead (Curle 1911; MacGregor 1976, nos 24 & 25), Traprain Law (MacGregor 1976, nos 26–9), Middlebie (*ibid*, nos 22 & 23) and Corbridge (*ibid*, no 21).

None of these objects has been found in closely dated contexts, but the majority come from northern Britain and so could not be earlier than the Flavian period. The earliest piece is that from the Seven Sisters hoard which, it has been argued, was deposited at the time of Ostorius Scapula, c AD 52 (Webster 1982, 135). This is an exceptionally well-decorated example and it is evident that many of the others have become debased and much simpler in design, but this could have occurred over a considerable period. Whether, however, these pieces of harness continued in use into the Antonine period was doubtful, since by then, as Jürgen Oldenstein (1976) has demonstrated, totally different forms were in existence. Such is the general uniformity of military equipment in the Roman army, that it would be necessary to argue that development in Britain was exceptional. Odd pieces

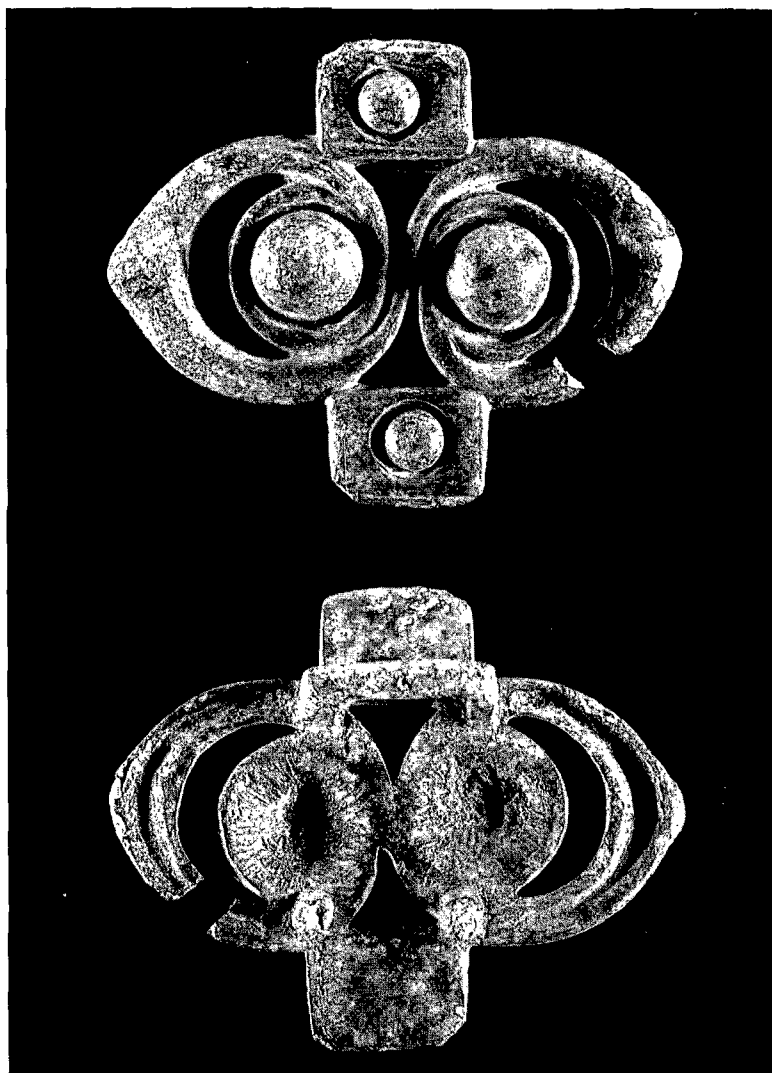

ILLUS 14 Harness strap junction, front and back

of valued equipment could have remained in use as family possessions, but this does not explain the number of finds from the north. The Kinneil piece was found in the demolished rampart debris in the north-east corner of the fortlet in a context which suggests that it comes from the end of the Roman occupation of Scotland c AD 165. The pieces from sites in southern Scotland, such as Newstead, Traprain Law and Dumfriesshire, may also be late.

OTHER OBJECTS

Geoff B Bailey

1 Axe (illus 15) The iron axe-head with an oval eye is typical of Roman military finds of the first and

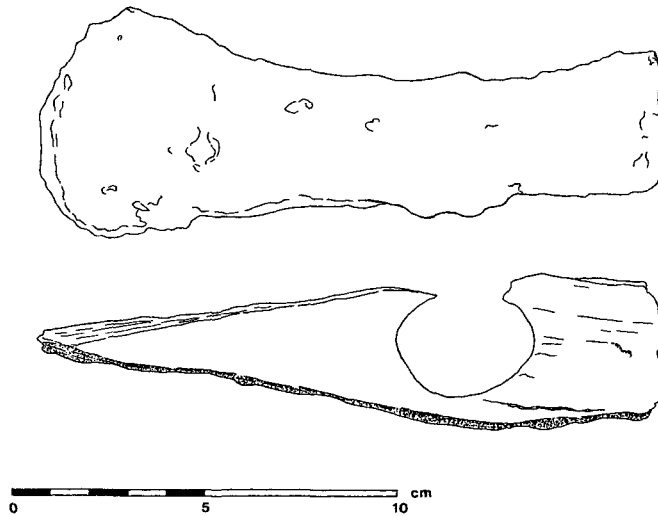

ILLUS 15 The axe

second centuries AD. It has the corroded remnants of paired lugs on the upper and lower surfaces by the eye. The heavy butt for hammering counterbalances the single blade, the two forming part of the graceful curve of the lower surface. It is 164 mm long with a restored blade length of 71 mm.

Such axes are surprisingly frequent finds on Scottish sites. They have been found in Flavian contexts at the auxiliary forts of Strageath (Frere & Wilkes 1989, 160) and Newstead (Curle 1911, 282), as well as the legionary fortress of Inchtuthil (Barclay & Maxwell 1991, 42). The Antonine forts of Newstead (*op cit*, 283), Birrens (Robertson 1975, 128 no 40), Loudoun Hill (Robertson & Scott 1980, 27), Ardoch (Christison *et al* 1898, 463), and Bar Hill (Macdonald & Park 1906, 113) have all produced axes of this type (see also Manning 1966, 11–13 for further distribution).

The Kinneil axe was found in the backfilled north terminal of the east fortlet ditch.

- 2 Coin A copper alloy disc with no impression now left on it. 33 mm diameter. Probably a *sestertius* of the late first century AD. Recovered from the topsoil above the western road drain.
- 3 Quernstone (illus 16) Just over half of a lower quernstone manufactured from a stone with a high mica content and quartz veins. There is a raised ridge around the pecked hollow of the socket. An opposed hollow is found on the slightly inturned under side. In form it is similar to a native specimen from Hurly Hawkin of the second century AD (Taylor 1982). It was found incorporated into the foundation of the Antonine Wall.
- 4 Spearhead A very corroded piece of iron 137 mm long possesses the rough form of a spearhead though no details are visible. It has a conical end expanding into an amorphous mass 41 mm in diameter, at 60 mm from the point it rapidly diminishes to a shaft with a diameter of 17 mm before expanding to 25 mm diameter at the other end. Found in the topsoil above the area of the north-east hearth (see B on illus 3).

NAILED SHOES (WITH A NOTE ON A SHOE FROM CASTLECYARY)

Alexandra T Croom

The lower levels of the large pit (Context 170) were waterlogged and found to contain 11 large fragments of leather from shoes as well as numerous small pieces, some too small to be included in

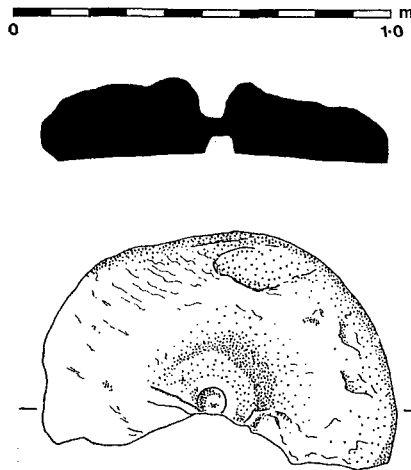

ILLUS 16 The quernstone

the catalogue below. This group provides a useful augmentation to the extensive collection of footwear from the Wall fort at Bar Hill (Keppie 1975). The opportunity is also taken to publish an earlier find of a shoe from the Wall fort at Castlecary and now in Falkirk Museum.

All the surviving fragments come from nailed shoes. Holes and impressions on the leather show the hobnails had square shanks 2mm wide and circular heads 7 mm in diameter. A few holes in the shoe from Castlecary have traces of hobnail shanks in them, but in general there is very little trace of any iron remaining.

The leather of these shoes is generally in a poor condition, and it is sometimes difficult to tell grain from flesh sides; on the uppers of shoe no 3, only a small area of the original grain on the exterior quarters distinguished the two surfaces. It has not always been possible, therefore, to say with certainty which way the leather has been used. In Roman shoes generally, the lower sole has the grain side downwards, and the inner soles upwards. At least two different types of leather have been used, consisting of a thicker leather of the soles and a fine, thin leather for some of the uppers, but because of their poor condition it has not been possible to identify the species from which they came.

The catalogue consists of a description of the shoe, measurements of the surviving length of sole and the width across the tread (unless otherwise stated) and context:

1 Shoe (l:235 mm; w:78 mm) 283

The uppers are made from fine leather only 1 mm thick (illus 17), with high-quality cut-work decoration. There is a plain centre-front vamp seam, with a curved double line of stitch holes on the outer side of the vamp (stitch length 3 mm) that is not matched on the inner side. This feature is also found on shoe no 2 below. Beyond the seam there is a semicircular zone of cut-outs with cusps between the straps. This extends up to the eyelet at the ankle, which has a decorative notched back edge. Along the top edge of the solid semicircle above the cut-outs and along the edge of the quarters there is a hem line of double running stitch 4 mm from the top (illus 18). At the back of the quarters there is a triangular tab with notched edges. Below each eyelet and the heel tab there is a decorative roundel, consisting of an outer circle of lightly punched crosses and an inner circle of fine cusped triangles that cut right through the leather.

The bottom unit (illus 19) consists of one almost complete lower sole, a middle and an inner sole. The lower sole has a pointed toe and narrowed waist, with surviving hobnail impressions. The inner soles have no surviving thonging, but they are fragmentary and in poor condition, and there are some holes that could possibly be thonging holes.

Nailing pattern: Padley 1991 Type B, but with straight lines under the tread, a diamond at the waist and a curved line under the heel.

Left foot.

The workmanship on this shoe is of high quality, with very fine cutting of the delicate straps and the intricate roundel decoration. The amount of work involved in its manufacture suggests a high-status shoe (illus 20). Shoes with openwork arcs by the eyelet have been found at various sites, but in these examples there are two eyelets to each side and the openwork is immediately below them, rather than to the front as in this example (Castle Cary: Anderson 1903, fig 40; Newstead: Curle 1911, pl XX, no 7; Carlisle: Padley 1991, fig 209, no 895). At Bar Hill, Keppie (1975) categorizes this form as a Type C *calceus*, but notes that there is great variation within the type. There is one example within the Bar Hill group that does have the cut-outs on the vamp in a rough semicircle under the vamp seam rather than under an eyelet (Keppie 1975, fig 23, no 35; see also fig 24, no 35). Another example from Bar Hill has a notched edge on the heel-tab (ibid, fig 23, no 28).

2 Shoe (w:57 mm) 281

Fragmentary remains of a shoe, with thin uppers with a plain centre-front vamp seam (fragments 1, 2) and cut-outs with fine crescentic punched holes at the base of some of the straps (1, 3, 4, 5, 6). A fragment (not illustrated) from the top edge of the quarters has three semicircular promontories. There are also fragments of uppers with large circular holes (7, 8) or dumb-bell shaped holes (9) very near the cut edge. One side of the vamp (1) has a line of irregular stitching with paired holes (stitch length 3 mm) that is not matched on the other side (cf no 1 above). There are fragments of the lasting margin (10) and an incomplete inner sole of thin leather with a large X scored on the upper surface and thong impressions on the lower surface (11). One of the thongs (12) may come from this sole. There are other fragments of uppers and inner soles or well fillers (13–16), and a heel fragment of a thicker inner sole with a skived edge.

The remains of this shoe are very fragmentary (illus 21), but its design is clearly parallel to examples found in Hardknott fort, with a vamp seam, strap cut-outs with decoration at the base, and promontories on the quarters (Charlesworth & Thornton 1973, shoes nos 2–4, 6–8).

3 Bottom unit with remains of uppers (l:245+ mm; w:83 mm) 281

The uppers are made out of 2 mm thick leather, but have been cut away in the main, presumably for reuse. The lasting margin is wide enough under the tread to meet down the middle, but is narrower at the waist and heel. There is no surviving well filler or heel stiffener. The inner sole, the only one surviving, is almost complete, with a narrowed waist and pointed toe, and skived edges (illus 22).

Nailing pattern: Padley 1991 Type C, with two straight lines under the tread, one isolated nail at the waist and a cluster under the heel.

Left foot.

4 Bottom unit (l:236+ mm; w:85 mm; thong w:4 mm) 281

Two thin inner soles with a rounded toe and narrowed waist, thonged down both sides (illus 23). The middle or lower sole has the grain side up, but also has impressions of circular-headed hobnails on the lower surface. This sole has no noticeable waist.

Nailing pattern: Padley 1991 Type B, with two straight lines under both tread and heel, and two nails at the waist.

Right foot.

5 Bottom unit (l:209+ mm; w:88 mm) 281

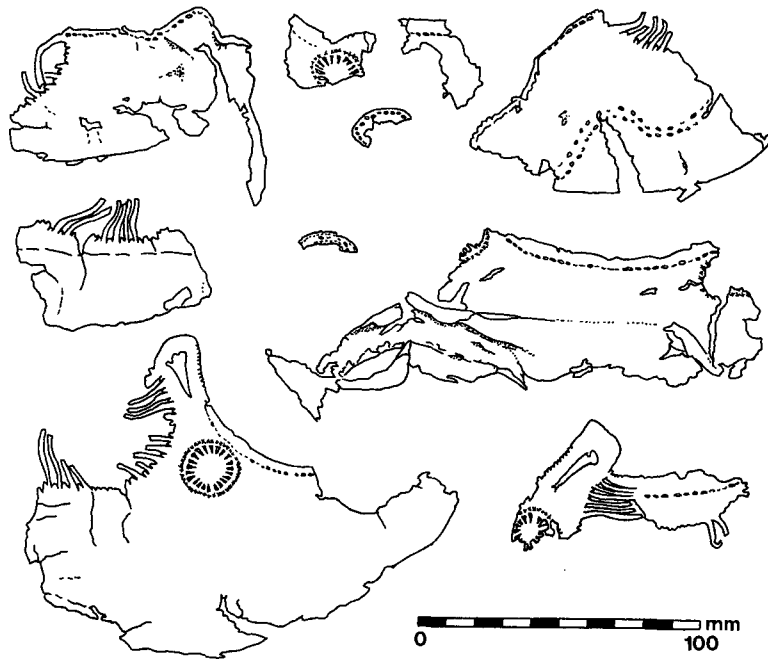

ILLUS 17 Upper fragments from shoe K1



ILLUS 18 Shoe K1 showing pieces in approximate position for cutting

Fragmentary inner sole with a more complete ?middle sole (illus 24). This second sole is grain side up, with skived edges, suggesting a middle sole, although it does have the impression of a few hobnail heads on the lower surface. It has a rounded toe, and an almost straight inner side, but it widens considerably on the outer side at the tread and heel.

Nailing pattern: probably double line of nails on both sides.

Right foot.

- 6 Bottom unit with heel stiffener (l:224+ mm; w:84 mm; heel h:37 mm) 281
Bottom unit with rounded toe and narrowed waist (illus 24). There are at least four layers, although there is no surviving thonging, and a crescentic heel stiffener.
Nailing pattern: Padley 1991 Type B.
Right foot.

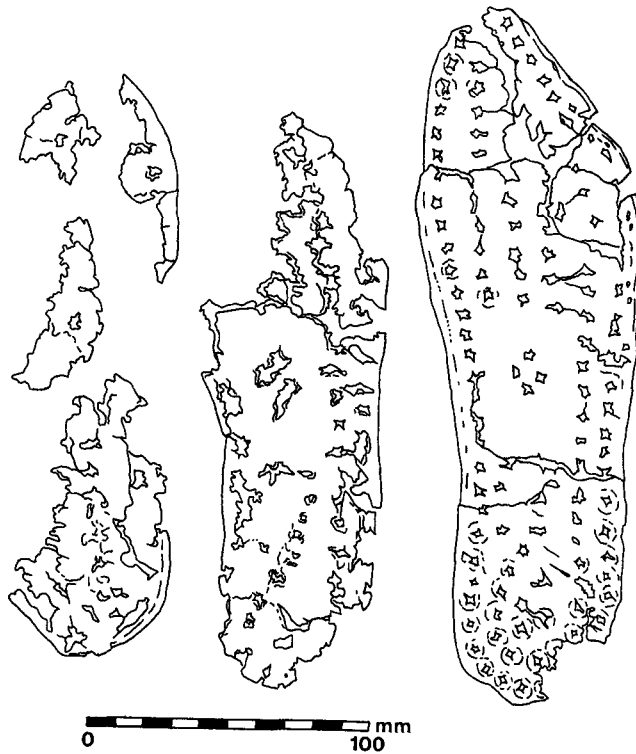

ILLUS 19 Shoe K1 bottom unit

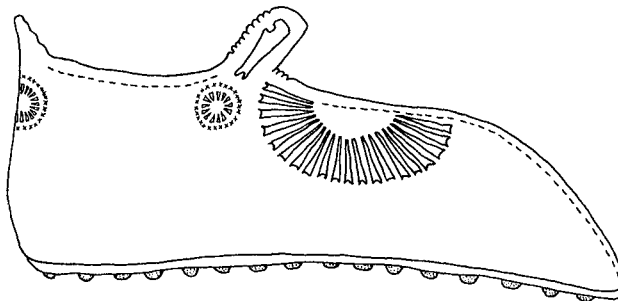

ILLUS 20 Shoe K1 reconstructed

- 7 Heel stiffener (h:33 mm; sole w:50+ mm; thong w:5 mm) 281
Heel stiffener with lasting margin, grain side out (illus 24). Associated with an incomplete inner sole with the remains of thonging. This is possibly from the same shoe as no 10 below.
- 8 Heel stiffener (h:37 mm) 282
Heel stiffener with lasting margin, grain side out, rising to a peak towards the right-hand side (illus 24). The upper edge has a line of stitch holes grouped in pairs. Although heel stiffeners were not usually sewn

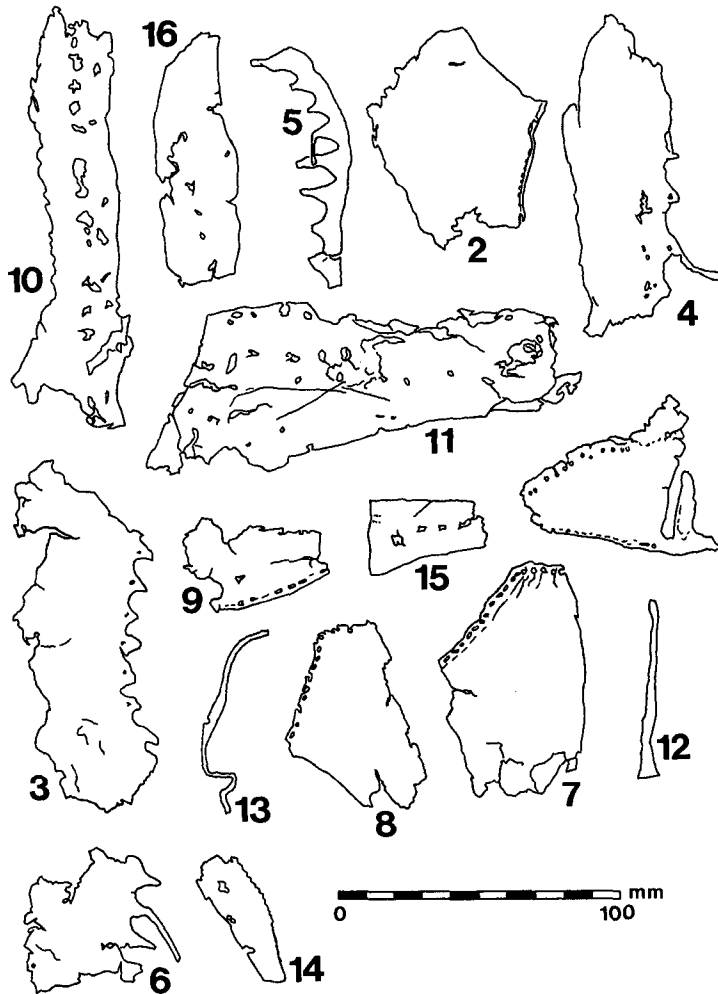

ILLUS 21 Shoe K2 upper fragments and inner sole

into the shoe, an example from London also has an apparent line of stitching along the top (Rhodes 1980, 110).

- 9 Heel stiffener (h:38 mm) 282
Crescentic heel stiffener with lasting margin and skived upper edge (illus 24).
- 10 Inner sole (w:81 mm) 281
Incomplete inner sole with highly pointed toe. Possibly from same shoe as no 7 above.
Other fragments of inner soles include: one piece with thonging holes; one with edges and heel area.
- 11 Well-filler (l:110 mm; w:37 mm) 283

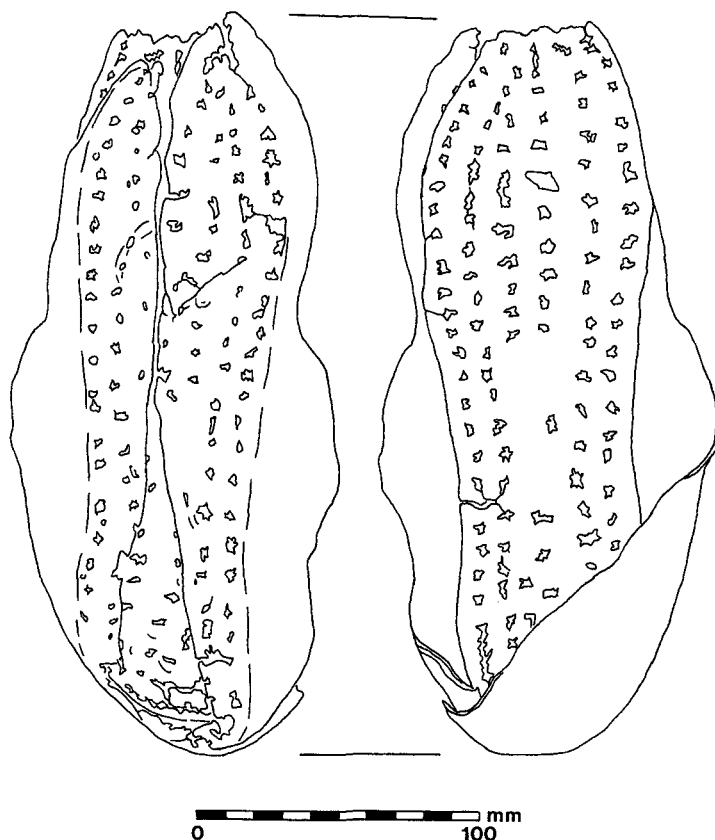

ILLUS 22 Shoe K3 bottom unit and heel stiffeners from both sides

Well-filler, with skived edges on three sides. Associated with fragments of thin leather uppers which have no distinguishable features.

Castle Cary fort shoe

- 1 Bottom unit (l:234+ mm; w:90 mm; thong w:5 mm) not recorded.
 Inner and middle sole with pointed toe and narrowed waist and heel (illus 25). The inner sole is slightly smaller than the middle sole. They are thonged together, both grain side up.
 Nailing pattern: Padley 1991 Type C1.
 Left foot.

The majority of fragments in this collection are the bottom units of nailed shoes; Rhodes (1980, 100–1) has discussed the possible reasons for the disproportionate recovery of bottom units of excavated shoes. These units are difficult to date by themselves, but the two shoes with surviving diagnostic uppers are types dated generally to the first and second centuries. Their presence at Kinneil shows that these designs were still clearly in use during the Antonine period. The workmanship on

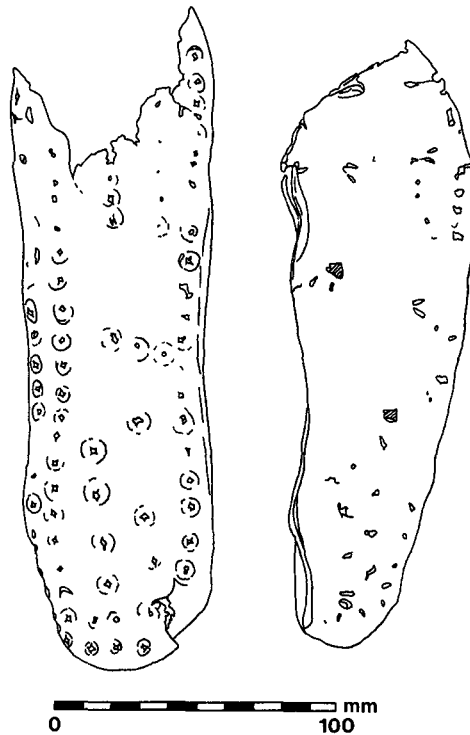

ILLUS 23 Shoe K4 bottom unit

shoe no 1 in particular shows the level of sophistication leather craftsmen could produce, and the quality of material to be found even within a fortlet.

THE POTTERY

Peter V Webster

As one might expect, even from the total excavation of the interior of the site, the fortlet did not produce a large quantity of pottery sherds. The greatest amount, by bulk, represented the amphorae, but even these may not represent many vessels. Other coarse pottery (illus 26 & 27) and Samian ware was generally found in small pieces and somewhat eroded by soil action. Pottery sherds were found throughout the fortlet, in both phases, in contexts which included post-holes, ditch fills, drain sediments, and the fills of the well/latrine pit as well as within the dismantled superstructure of the ramparts.

Chronology

The pottery adds little to the chronology of the site as deduced by its position. The great majority of the material would be designated as Antonine, wherever it had been found. It may be noted, however, that there are a few pieces (nos 34, 40) which would better suit an earlier second century context.

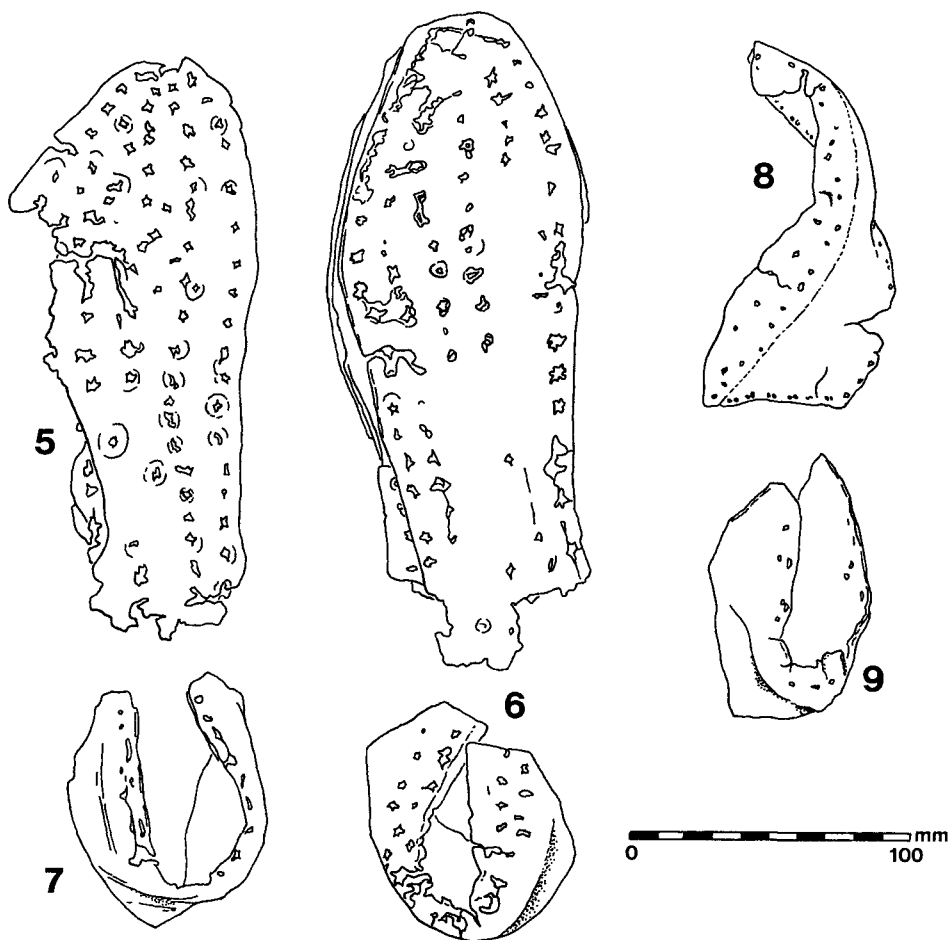

ILLUS 24 Shoe K5-9 bottom units and heel stiffeners

These are not sufficient to allow us to postulate an underlying site and are probably best seen as pieces which were already a decade or more old when they were imported onto the site.

If the Antonine Wall was itself held for less than a generation, as is currently generally supposed, then there is little scope for detecting pottery which is sufficiently distinct to be certainly late in the period. At Kinneil, one can note only that the pottery is in no way exceptional for a Wall site and that there seems no reason to unduly restrict the period represented. Typologically 'early' pieces have already been noted and these would best suit activity at the beginning of the Antonine period. There are, however, also later pieces (eg nos 8, 9, 16) which would seem more appropriate for activity late in the history of the Wall.

Sources of pottery

The Kinneil pottery was drawn from a fairly restricted set of sources. Samian ware is represented by a very small number of fragments indeed and other fine ware is represented only by a few scraps of

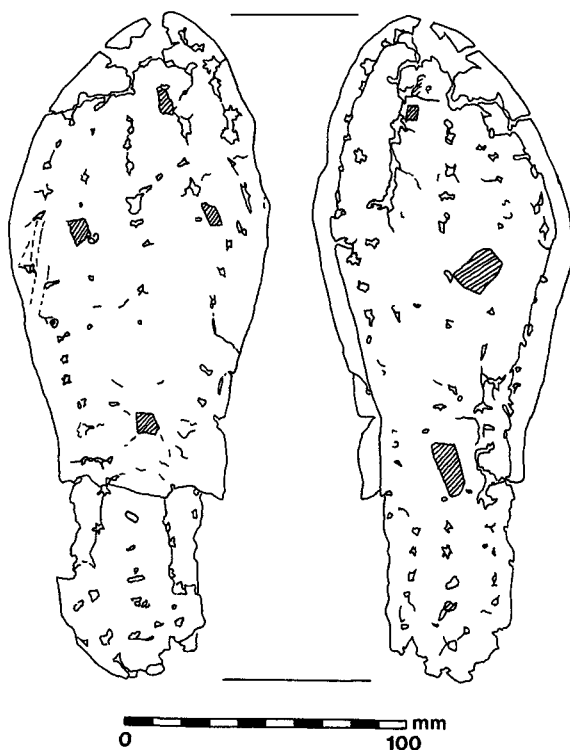

ILLUS 25 Bottom unit of a shoe from Castlecary viewed from both sides

colour-coated ware, probably from Colchester. Amphorae form the bulk of the finds by volume or weight, but as few as six vessels may have been present, all of Dressel form 20, the common south Spanish oil amphora. Mortaria represented two major sources, Colchester and Scotland. (In view of the absence of other local products, the Scottish mortaria are of particular interest and add to the growing body of pottery known to have been produced locally for the Antonine frontier.) Black-burnished wares were the predominant type if measured by vessel count.

Other sources are represented by only one or two vessels each. Two things may, however, be noted. The sources, where apparent, seem mainly to be in south and east England as one might perhaps expect, given the easterly position of Kinneil on the frontier. Secondly, local sources, at least among the coarse pottery, are absent.

The Kinneil assemblage as a whole shows clearly the reliance which the Antonine frontier placed upon imports from the south. West coast routes are presumably implied by the presence of BB1, east coast by BB2, the Colchester mortaria and many of the other coarsewares. The easterly bias seen in the assemblage as a whole is presumably a product of the fortlet's location within the frontier zone. The collection is, however, as interesting for what it does not contain as for what it does. The Koln/Nene Valley and the North Gaul/Argonne finewares are totally absent as is Severn Valley Ware. There is no sign of a local potter in the immediate vicinity of the fortlet (or, indeed of a civil settlement in which he could have operated). Everything appears to have been brought in, sometimes only a short distance, more generally over a much longer one.

TABLE 1
Distribution of pottery forms by function

	No	%
<i>Tableware</i>		
Samian	8	13
Fineware	1	2
Flagon	1	2
<i>Kitchenware</i>		
Amphorae	5	8
Jars	26	43
Bowls	6	10
Dishes	7	11
Mortaria	7	11
TOTALS	61	100

Social and economic implications

Deductions from such a small assemblage as this must inevitably be tentative. However, two aspects of the collection have already been noted. There is a general absence of fineware. Only eight Samian vessels and one colour-coated beaker are represented by small scraps, making nine vessels (c 15%) out of a total of about 61. With only one other vessel likely to have served as tableware, the great majority of the vessels recovered (c 83%) can be classed as kitchenware. Even among the kitchenware, distributions by function seem unusual as Table 1 shows:

The predominance of jars is apparent and this must presumably have some bearing on the nature of the activities carried out in the fortlet. There seems an undue emphasis on subsistence and little on the more social aspects of existence. With only one flagon and few cups apparent, even much in the way of drinking seems to be excluded. A garrison operating with the Roman equivalent of field-rations, rather than one in permanent occupation might be implied.

CATALOGUE

All rims have been noted or illustrated. Accession numbers are noted where relevant after context numbers.

Samian The site yielded a very small amount of very abraded Samian. Small fragments of about eight vessels are represented as follows:

source	form	number
Central Gaul	18/31	c 3 vessels
	18/31R	1 vessel
	37	2 vessels
East Gaul		1 small sherd

Of the two vessels of decorated forms, one was represented only by a rim. The other showed abraded panel decoration including a figure (possibly the Perseus, Oswald 1937.234) beside a divided, heavily eroded panel. The Cinnamus design (Stanfield & Simpson 1958, pl 160, 4) is not dissimilar, but our piece is too worn for certain identification and has not been illustrated. All but one sherd of Samian was from topsoil (KN80.100; Acc nos 1983-1-13 & 15); the other sherd (form 18/31) was from a drain fill (KF80.152; Acc no 1983-1-57).

Colour-coated ware The site produced three small sherds of colour-coated ware beaker in bright orange-red

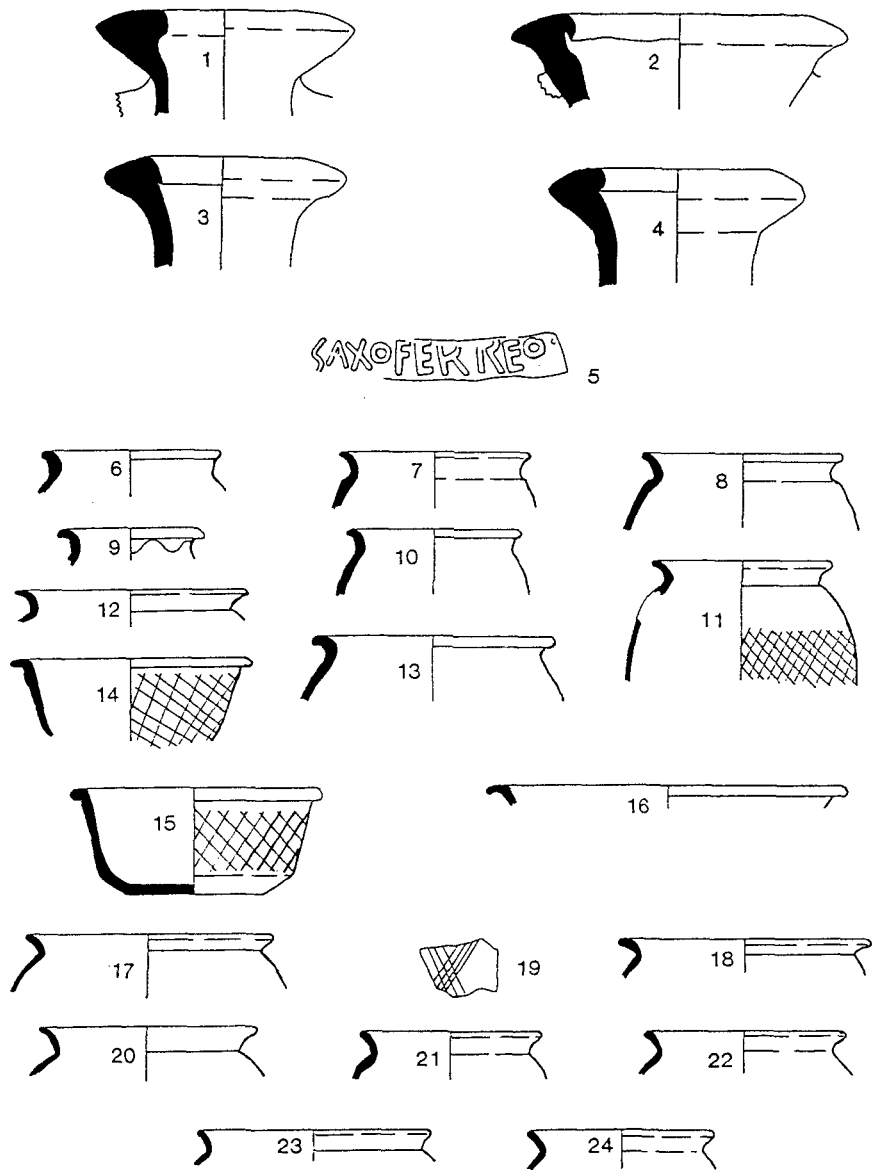

ILLUS 26 Coarse pottery (scale 1:5)

with a dark grey-brown colour coat. All could be from the same beaker. The likely source is Colchester (Acc no 1981-23-20).

Amphorae All amphorae were Dressel form 20, a type used for the importation of olive oil from southern Spain. A complete list of all amphorae sherds weighed by context can be found in the archive. Total weights are as follows:

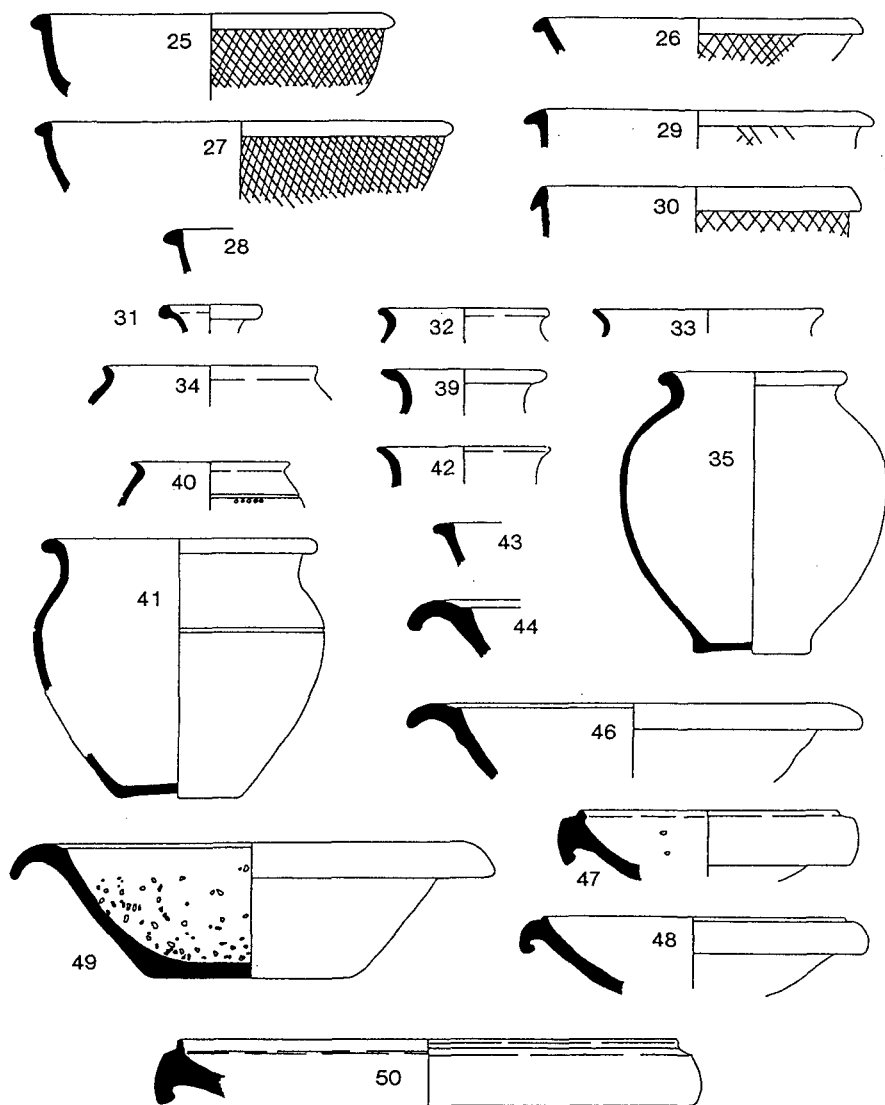

ILLUS 27 Coarse pottery (scale 1:5)

Dressel 20:	wall sherds	32.99 kg
	handles	2.78 kg
	rims	2.98 kg
	Total	38.75 kg

As a matter of general interest, this represents 1.36 complete amphorae using the average weight of 28.42 kg suggested by Peacock & Williams (1986, 52). Calculations of estimated vessel equivalents (EVES) achieved by adding percentages of whole rims and percentages of handle pairs produced 3.76 EVES for rims and 2.25 EVES

for handles. Such figures may allow statistical comparison with other sites. It is, however, relevant to record that examination of the rims suggested that fragments of at least six vessels were present, as follows:

- 1 Dressel 20 (Martin-Kilcher no 30; Peacock & Williams 1986, 138). Late first/mid-second century. KF80.131/134, Acc no 1983-1-49.
- 2 Dressel 20 (Martin-Kilcher no 32; Peacock & Williams 1986, 138). Early/mid-second century. KF80.100, Acc no 1983-1-1.
- 3 Dressel 20 (Martin-Kilcher no 29; Peacock & Williams 1986, 137). Mid-second century. KF80.328, Acc no 1983-1-89.
- 4 Dressel 20, badly eroded (Martin-Kilcher no 29; Peacock & Williams 1986, 138). Mid-second century. KF80.131/134, Acc no 1983-1-49; with another similar example from KF80.100.
- 5 Dressel 20. Amphora handle with a stamp reading *SAXOFERREO* (cf Callender 1965, fig 16, no 24 for a comparable stamp, but not from the same die; also p.242, no 1573). Callendar suggests an early to mid second century date. KF80.139, Acc no 1983-1-52.

Black-burnished ware BB1 and related fabrics are represented by nos 6–16. It may be noted that these are mainly jars and, indeed, that the jar to bowl/dish ratio on the site seems unusually weighted towards the former (see above). BB2 represented by nos 17–30 does, however, show no such bias, jars and bowls/dishes being approximately equal in number. It is interesting to note that the numbers of BB1 and BB2 vessels is almost the same, despite the fact that the former will presumably have had to be imported from the west, across the isthmus.

- 6 Jar in BB1, burnt grey and sooted externally (cf Gillam 1976, no 1). Early/mid second century. KF80.100, Acc no 1983-1-20.
- 7 Jar in BB1. There may be faint traces of wavy line decoration (cf Gillam 1976, no 3). Mid/late second century. KF80.100, Acc no 1983-1-20.
- 8 Jar in BB1, sooted externally (cf Gillam 1976, no 4). Late second century. KN78.9, Acc no 1981-23-11.
- 9 Jar in BB1. (A squatter version of Gillam 1976, no 3.) KF80.21, Acc no 1981-23-18.
- 10 Jar in BB1, sooted externally (cf Gillam 1970, no 123). Early/mid-second century. KN78.9, Acc no 1981-23-11.
- 11 Jar in BB1, sooted externally. The drawing is constructed from non-joining sherds. Post pit, west side of north gate, Acc no 1981-23-12.
- 12 Jar in a dark grey gritted fabric (the vessel resembles the BB2 jar, Gillam 1970, no 139, mid-second to mid-third century, but the fabric suggests a different source). KF80.100, Acc no 1983-1-24.
- 13 Jar in light grey to light brown coarse fabric, burnt. Probably burnt BB1. (Gillam 1970, no 131 is similar) mid/late second century. KN78.8, Acc no 1981-23-10.
- 14 Flanged bowl in BB1, sooted externally. (cf Gillam 1976, nos 34–5) early/mid-second century. KN80.19, Acc no 1981-23-14.
- 15 Flanged bowl in a fabric which is clearly related to BB1 but may not be from the main source(s), as the grit content seems a little low. The form too is unusual, being a hybrid of BB1 and BB2 forms. KN78.4, Acc no 1981-23-13.
- 16 Flanged dish in BB1. (The rim resembles Gillam 1976, no 65 but too little remains to show the decoration), late second century. KF80.100, Acc no 1983-1-21.
- 17 Jar in BB2. (cf Mumrills; Steer 1961, no 35 – analysed by DF Williams; see Dore & Greene 1977, no 5). South ditch, Acc no 1981-23-16.
- 18 Jar in BB2, with eroded surface; a more everted version of no 17 (above). Context as no 17, Acc no 1981-23-16.
- 19 Jar wall sherd in BB2 illustrated to show the lattice type. It is not clear which of the rims illustrated is from the same jar as the lattice. Context as no 17 above, Acc no 1981-23-16.
- 20 Jar in burnt and eroded BB2 (cf Gillam 1970, no 143). Base and wall sherds, probably from this vessel,

- show it to have had acute-angled lattice (not dissimilar to the Gillam type vessel). KF80.131/134, Acc no 1983-1-44.
- 21 Jar heavily sooted externally. The fabric is light grey and noticeably softer than that of nos 19–20. The surface is dark grey and burnished externally. (cf Mumrills; Steer 1961, no 53). KF80.131/134, Acc no 1983-1-43. There is a closely similar vessel from KF80.273, Acc no 1983-1-78.
 - 22 Jar in BB2 (cf Gillam 1970, no 139). KF80.138. With one rim sherd possibly from the same jar, both Acc no 1983-1-51. A rim from KF80.148, Acc no 1983-1-65, is very similar.
 - 23 Jar in burnt and eroded BB2 (cf Southwell; Tyers & Marsh 1979, fig 236, II F7). KF80.151, Acc no 1983-1-56.
 - 24 Jar in BB2 (cf Wilderness Plantation; Wilkes 1974, no 1). KF80.273, Acc no 1983-1-77.
 - 25 Bowl in BB2 (cf Mumrills; Steer 1961, no 42). KF80.289, Acc no 1983-1-84. With a joining sherd from KN80.20, Acc no 1981-23-12.
 - 26 Dish in BB2 (as Gillam 1970, no 311, but with lattice decoration). Mid-second to early third century. The inner wall is restored on the drawing. KF80.273, Acc no 1983-1-76. There is a similar vessel from KF80.100, Acc no 1983-1-27.
 - 27 Dish in BB2 (cf Gillam 1970, no 310; Bar Hill; Robertson, Scott & Keppie 1975, fig 57, no 11). KN80.20, Acc no 1981-23-17.
 - 28 Dish in BB2 (cf Mumrills; Steer 1961, no 48). KN80.20, Acc no 1981-23-17. Probably of similar size to no 27 and with lattice decoration.
 - 29 Dish or bowl in BB2. (The decoration is as Gillam 1970, no 310; rim is *ibid* no 311), mid 2nd to early 3rd century. KF80.281, Acc no 1983-1-81. There is a similar vessel but with lattice decoration from KF80.100, Acc no 1983-1-27.
 - 30 Bowl or dish in BB2 showing a tendency to laminate. The rim is unusual and may be the result of a mistake by the potter. There is, however, a similar rim on a vessel found at Colchester (Hull 1963, 137, fig 57 no 3). Unstratified.

Other fabrics Despite the number and variety of sources represented by the remaining part of the assemblage, local sources, as noted above, are not represented.

- 31 Flagon in creamy white fabric (cf Corbridge 1911; Forster & Knowles 1912, no 91), Antonine. KF80.100, Acc no 1983-1-17. Three neck fragments, Acc no 1981-23-9, and a wall sherd from KN78.5, Acc no 1981-23-27, could be from the same vessel.
Nos 32–4 are in a light grey-brown sandy fabric with signs of a light to mid-grey smooth surface.
- 32 Jar, KF80.155, Acc no 1983-1-60.
- 33 Jar. Burnt externally. KF80.100, Acc no 1983-1-20.
- 34 Jar. There is some similarity to Flavian/Trajanic forms and the piece could have been comparatively old when lost. KF80.100, Acc no 1983-1-20.
- 35 Jar in light grey micaceous fabric with a dark grey external surface. An almost metallic sheen has been produced by burnishing on the rim, neck, shoulder and near the base, leaving a smooth but matt central zone. KF80.283, Acc no 1983-1-82.
- 36 Jar (not illustrated) in light grey highly micaceous fabric. Only the shoulder and upper wall survives showing a smoothed shoulder, groove and decoration of applied dots in the same clay apparently flattened to produce an almost 'marvered' appearance. KF80.273, Acc no 1983-1-75.
- 37 Jar (not illustrated) in light grey micaceous fabric. Eight wall sherds show decoration of near vertical burnished lines. KF80.139, Acc no 1983-1-54.
- 38 (not illustrated). Three sherds of a large grey storage jar, with decoration around the girth in the form of a zone of lattice decoration. KF80.100, Acc no 1983-1-31.
- 39 Jar in orange fabric with a grey core and orange-buff surface. The vessel was probably fired at a low temperature as it has deteriorated badly in the soil. KF80.336, Acc no 1983-1-90.
- 40 Jar in smooth light grey fabric with a dark grey core and dark grey external surface. Below a shoulder groove is the top of a panel of applied dots. (Gillam 1970, no 68 represents the general type; see also

- Southwell: Tyers & Marsh 1979, fig 239, Types III B.1 and III E.1), late first to early/mid-second century. A somewhat early type for an Antonine context. KF80.328, Acc no 1983-1-86.
- 41 About a half of a jar in fine sandy grey fabric with a darker external surface and some sooting on the rim. Probably of SE origin (cf Hinton 1988, 276, no 864; Frere 1972, fig 124, *passim*). KF80.151 and KF80.100, Acc nos 1983-1-55 and 1983-1-31.
- 42 Bowl in red-brown fabric with a grey and black surface, burnished externally. A campanulate form seems probable. KF80.131/134, Acc no 1983-1-47.
- 43 Flanged bowl in light grey fabric with a darker surface and lattice decoration (cf Gillam 1970, no 218, shows the general type). ?Hadrianic/Antonine. KF80.100, Acc no 1983-1-27.

Mortaria The mortaria have been examined by Mrs K F Hartley and will eventually form a small part of a general study of mortaria from Scotland.

- 44 Mortarium in bright orange fabric with white trituration grits and traces of a white slip. Probably of Scottish origin (KFH). KF80.100, Acc no 1983-1-10.
- 45 (not illustrated). Mortarium spout in orange fabric with traces of a white slip, of similar origin to no 44 above and possibly from the same vessel. KF80.328, Acc no 1983-1-88.
- 46 Mortarium in fine orange buff with a buff surface and grey, black and white trituration grits. A Scottish origin is likely (KFH). KF80.134, Acc no 1983-1-40.
- 47 Mortarium in fine-textured buff fabric. Little trituration grit remains but one ?quartz grain and one orange stone visible. Probably from Colchester (KFH). KF80.162, Acc no 1983-1-61.
- 48 Mortarium in buff fabric. No trituration grits survive. Probably from Colchester (KFH). KF80.152. Acc no 1983-1-58.
- 49 Mortarium in a fabric varying from orange-buff to buff with large angular grey, red and white trituration grits. Probably from Scotland (KFH). KF80.100, Acc no 1983-1-12.
- 50 Mortarium in soft pink-buff fabric. Probably from Colchester (KFH). KF80.100, Acc no 1983-1-11.
- 51 Ten fragments of a jar in a highly micaceous light grey fabric with a darker surface which has been burnished externally to a polish which sparkles with mica. These were found together in the well. Many pieces are sooted but this probably occurred after breakage as the soot stains run over onto the broken surfaces. This is, therefore, not likely to be a vessel which was actually used to obtain water from the well, but one which got into it after breakage and presumably when the well was being filled in. No rim survives, making comment on the form difficult, but there is no reason to suppose that this vessel is other than Antonine in date. KF80.283.

ANIMAL BONES

Catherine Smith & Ian Hodgson

The assemblage of faunal remains was exclusively of cattle. The bones were generally eroded and discoloured. Elements recovered included teeth, vertebrae and a rib, as well as fragments of long bones, a scapula and a skull. These derived from only three contexts: a post-hole (Context 239), remnants of the rampart superstructure (Context 134) and a basal fill of the well/latrine pit (Context 283). All of the bone was heavily butchered and represented parts of the carcass used for meat or stock.

DISCUSSION

PHASE I

The Rampart base of the fortlet was constructed in the normal manner. There was a distinct lateral variation in the size and composition of the material used in the core which indicates that it was derived from a number of different sources and brought in by the cartload. Masons' debris, in the

form of chippings, shows that the kerbstones were dressed on the site. A broken quern stone of native form was incorporated into the rubble core, possibly indicating the existence of a nearby native dwelling. Perhaps this settlement was displaced for the building of the Roman frontier. Such an incident is only to be expected, and is also indicated at Callendar Park where a cultivation soil was sealed by the upcast material from the Ditch of the Antonine Wall, and at Falkirk where a possible cattle stockade was swept away by the Roman fort (Bailey 1995; Bailey forthcoming).

A linear alignment of stones traversed the rampart base of the Antonine Wall, at right angles to the kerb at the point where the east rampart of the fortlet joins it. Such features have been recognized on other excavations and have been identified as demarcation lines where there was a change in work gangs (Keppie & Breeze 1981, 245). Some of these are to be associated with specialist work squads building the more complex structures found at stream crossings (Bailey, this vol). At Kinneil we may be seeing a similar situation with a specialist squad being brought in to build the fortlet. The location of the demarcation line is crucial to this suggestion. The line does not occur at one end of the fortlet's frontage as it would if the fortlet had been constructed as a freestanding structure before the Rampart of the Antonine Wall (Keppie & Walker 1981, 151). Rather, the line lies central to the fortlet's east rampart, and furthermore is edged on the west, indicating that the Wall to the east of the fortlet was built first. From this we may conclude that the base of the Wall was laid out before that of the fortlet, leaving a gap where the latter was to be built – as was the case with the Antonine Wall bridges. Some of the Hadrian's Wall milecastles were also built after the linear element of the frontier there (Simpson & McIntyre 1933, 269).

How long a time lag there may have been between the work of the Wall gang and that of the fortlet gang we cannot tell. It is possible that the superstructures of these two elements were built contemporaneously as the south Wall cheek does not continue across the north-east end of the fortlet's east rampart. However, it is equally possible that there was some significant delay and that the adjacent Wall rampart was partly demolished and reconstructed alongside that of the new fortlet in order to tie the two together more effectively.

The Antonine Wall base was of the standard width at 4.3 m, but the fortlet ramparts were reduced to 3.0 m. They are thus similar in dimensions to those at Seabegs, Wilderness and Croy, all of which were contemporary with the construction of the Wall. This contrasts sharply with the freestanding fortlets of Cleddans and Duntocher where the ramparts had a uniform width all the way round of 3.6–4.0 m.

The Rampart material at Kinneil is consistent with what is already known of this sector of the Wall in that it was probably composed of an earthen core revetted by narrow cheeks of either clay or turf. However, the disturbed nature of the site made it impossible to make a positive identification of the cheek material. It has been argued elsewhere that the construction of the Antonine Wall was deliberately implemented in a succession of orderly phases according to military and political priorities (Bailey 1992, 6). That part of the frontier lying to the south of the River Forth and the River Carron was evidently given a low priority in this scheme and was the last length to be completed (Bailey 1995). There is no evidence from Kinneil which can be used either to support or reject this hypothesis.

The change in the width of the Ditch in front of the Wall occurs more or less where a causeway might have been anticipated opposite the north gate of the fortlet. Such a causeway was left at the fortlet at Watling Lodge which continued in use throughout the lifetime of the Antonine Wall (Keppie *et al* 1995). It is reasonable to assume that one existed at Kinneil and that it was subsequently removed. The change in width at a causeway can be paralleled at Castlecary fort (Christison & Buchanan 1903) and is believed to signify a change in work gangs (Keppie 1974).

Only one ditch was found to surround the fortlet in the 1980 excavations, though given the

TABLE 2 Comparative figures for numbers of post-holes within Wall fortlet entrances (figures in brackets are those actually excavated)

fortlet	No of posts		rampart width (m)
	S gate	N gate	
Kinneil	3	5	3.0
Seabegs	7 (4)	7 (3)	2.8
Wilderness	—	7 (3)	3.0
Croy	—	—	2.7
Cleddans	—	—	3.6–4.0
Duntocher	3	—	3.7
High House	3	5	6.1

difficult ground conditions and heavy plough truncation it remains possible that a second lay beyond it (see Keppie & Walker 1981, 151). In Trench 9 a possible bifurcation of the ditch occurred which could produce a pattern similar to that at Seabegs. Trench 10 showed that there was no causeway corresponding to the direct line of the road issuing from the south gate. This situation also occurred at Duntocher and so we must consider the possibility that it was bridged by a wooden structure to avoid drainage problems.

The fortlet itself is of the long-axis type and displays a number of features in common with the other fortlets along the Wall and with the milecastles of Hadrian's Wall. If we take each feature in turn it will be useful to determine their form and probable usage before moving on to analyse the general layout within the ramparts.

The form of the gateways is of the simple type 1C of Manning's classification, a feature that it shares with most fortlets (Manning & Scott 1979, 22) (Table 2). The distribution of post settings at the two gateways finds a close parallel at High House milecastle on the turf rampart of Hadrian's Wall. It too had five posts on either side of the north entrance and three (deduced) at the south entrance. This led the excavators there to conclude that the north gateway possessed a tower, while the south one merely supported a continuation of the rampart walk (Simpson, Richmond & St Joseph 1935).

On the Antonine Wall the fortlet at Duntocher also had three posts along the south gate passage, but unfortunately the area of the north gate was too disturbed to determine the number there. The ditch system around this fortlet appears to confirm that the north gate was more important and presumably better defended (Robertson 1957, 23). Yet at Seabegs both gates probably had seven posts, a number they have in common with the north gate at Wilderness (Keppie & Walker 1981, 145–6; Wilkes 1974, 55). At Seabegs both gateways therefore held the potential of a tower. Why there should be such a difference in numbers is unclear. Additional posts could have been simply to support the bratticing of the pend and may have played no part in the main structure. It is even possible that each legion had its own design which produced this variation.

The internal arrangements are remarkably similar to those of the milecastles on Hadrian's Wall (Table 3). Most of the enclosed area was occupied by two buildings, one on either side of the through road. While it is difficult to reconstruct the exact lines of these structures it is clear that they were both in the region of 15 m long by 4.1 m wide, possibly with a veranda fronting the road. Building 1 seems to have been a four-room structure.

These buildings were freestanding with the back wall placed 1.0 m away from the ramparts and the south walls c 1.5 m distant. This would leave dark narrow allies which would allow access to both the rear of the ramparts and the exterior face of the buildings. These must have been damp, airless places, sheltered by the ramparts but receiving run-off water from the roofs and rampart walks when it rained.

Both the evidence on the ground and a comparison with other fortlets shows that these buildings stopped well short of the north rampart, leaving room for a pair of ancillary lean-to structures. Typically these were occupied by hearths and ovens. At Kinneil, an extensive area of burning was associated with the west lean-to. On the site of the east lean-to, an area of burning also occurs and may represent a hearth (next to B on the plan). Hearths in similar locations were noted at Wilderness (Wilkes 1974, 56), and in the partly excavated fortlet at Cleddans burning also occurred in the north-east corner (Keppie & Walker 1981, 156). At High House on Hadrian's Wall a brazier lay to the north of the east building (Simpson, Richmond & St Joseph 1935). These can be seen as cooking areas for the garrison.

These lean-to shelters were relatively light structures, as indeed were the equivalent buildings at Biglands which had walls of turf (Potter 1977, 160). The east/west stone foundation to the north of Building 1, with a post-hole at either end of it, represents the south wall of the west lean-to. The lean-to opposite to it is only represented by a small curving gulley bounding a strip of rammed gravel, which possibly bore a sleeper beam. Internally this had a beaten earth floor of redeposited clay. Both of these lean-to shelters are separated from the buildings to the south by short metalled paths.

Yet another direct parallel with the High House milecastle lies in the location of the large pit (Context 170). At High House there were two pits: A was 2.1 m deep, and B in the north-west corner was slightly larger. These were interpreted as demolition pits dug to receive material during the dismantling of the station (Simpson, Richmond & St Joseph 1935, 227). However, it is far more probable that these pits already existed for some other purpose, and were simply used as convenient places to dump building debris and other waste material during final demolition work (cf the well at Bar Hill – Macdonald & Park 1906). Along with the use of the defensive ditches, particularly at their terminals, this was common Roman practice when cleaning up a site (Bishop 1986). There are two main possibilities for the primary function of these pits. They may have been cess pits, or wells. The twigs in the base of the Kinneil pit combined with the shape and pattern of the fills hints at the possibility that the pit had an internal lining of wattle. This would suit both of the above functions. At High House, a separate latrine was found with a drain issuing from the south gate which would suggest that similar large pits here were not latrines but were for the provision of water. At Kinneil, where the adjacent lean-to structure is interpreted as a cookhouse, the proximity of a latrine pit would certainly have been undesirable. A pit, possibly a well, was found adjacent to the east cookhouse at Biglands (Potter 1977, 163). On balance it would seem that the large deep pit in a similar position at Kinneil was also a well, though whether it derived its water supply from the water table which lay some way above its base, or from the collection of rain water from the roofs of the adjacent buildings is unknown. The metalled surface which surrounds it would have given easy access to the well head.

Another common feature of the Hadrian's Wall milecastles is the provision of a stair or *ascensis* in one of the northern corners. High House had a 'rectangular mass of turf in the north-east corner, marking the foot of the stair to the rampart-walk' (Simpson, Richmond & St Joseph 1935, 222). At Duntocher a layer of turfs occurred just within the north-west corner (Robertson 1957, 29). Seabegs had rough cobbling overlying a layer of turfwork 0.1 m thick in a similar location (Keppie & Walker 1981, 146). Small patches of 'turfwork' were noted in the north-west corner at Kinneil which could well represent the same phenomenon. These were bounded on the south by an area of burnt earth and stone and by a post-hole.

All in all, it is evident that the interior of the fortlet was quite built up, with the timber buildings occupying most of the available space. The recent excavations at Swarthy Hill milefortlet on the Cumbrian coast demonstrate how the quality and nature of these buildings might vary. There the

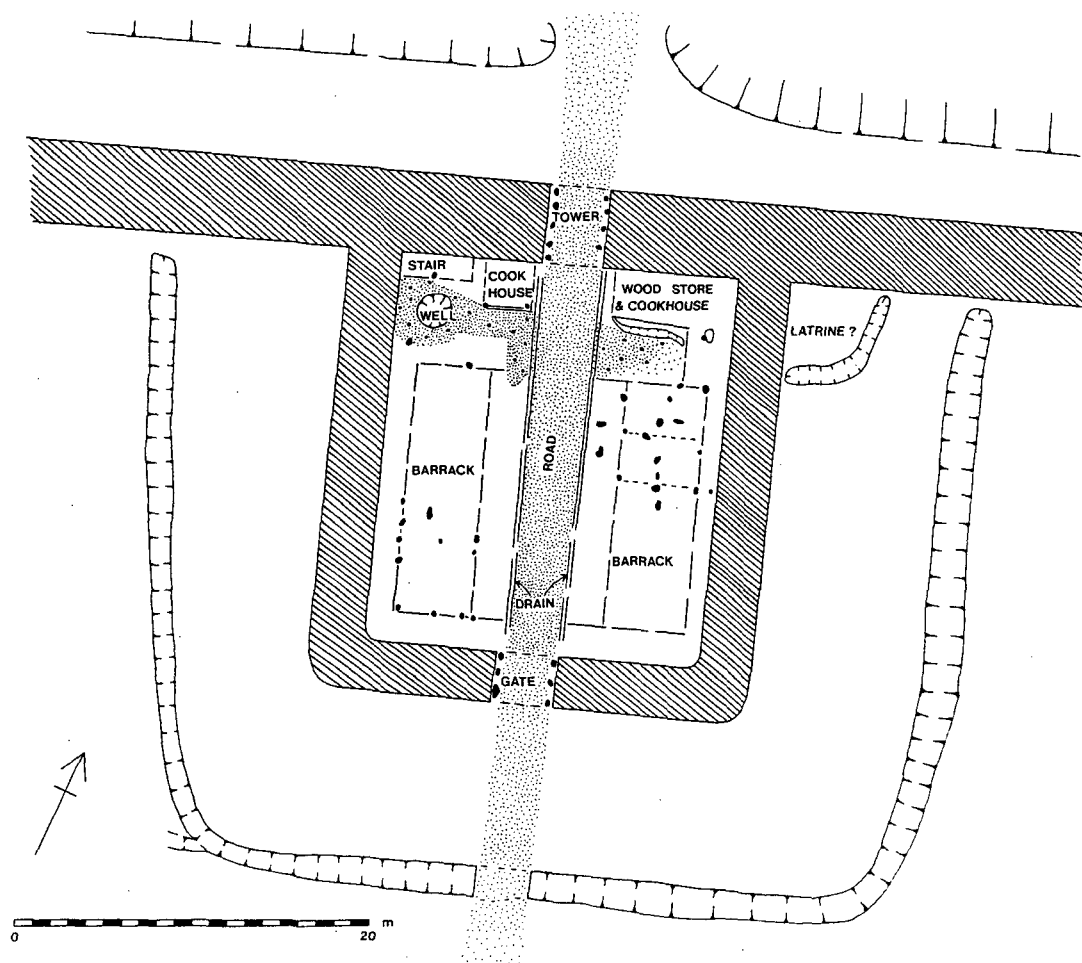

ILLUS 28 Reconstruction of the fortlet in Phase I indicating probable uses of the buildings and other features

buildings were constructed of earth, clay and turf leaving only slight traces on the ground. Even the backs of the main buildings were formed from the ramparts (Frere 1992, 270–1).

With little need for storage in the fortlet, Buildings 1 and 2 were both probably barrack blocks. Food might be obtained from the forts on a regular basis, perhaps when the garrison of the fortlet changed. It is generally thought that the troops manning the fortlets were outstationed on a rota from the neighbouring forts and this might explain the small range of types in the pottery assemblage (see Webster, above). The well and the cookhouse catered to the men's culinary needs. How many men were in garrison is still unclear from the excavation. At Poltross Burn milecastle there were two stone barrack blocks each with four rooms. If each room represented a contubernia of eight men then there would potentially have been 64 at that station. Alternatively each contubernia could have occupied two rooms, using one for storage as in a normal fort, in which case we can reduce this figure to 32 men. However, the earliest phase at Sewingshields contained only a small two-cell

TABLE 3 Comparative figures for building dimensions within Wall fortlets (Mc = milecastle; after Breeze & Dobson 1972, 189)

	fortlet	dimensions of buildings (m)
Antonine Wall	Wilderness	6.1 × 4.3
	Duntocher	7.3 × 6.5
		11.0 × 6.5
Hadrian's Wall	High House Mc 50	9.7 × 4.1
	Mc 9	6.1 × 3.4
	Mc 37	c9.8 × 4.0
	Mc 47	16.0 × 4.0
		15.8 × 3.4
	Mc 48	16.0 × 3.7
		15.2 × 4.0
	Mc 54	8.3 × 3.7

building in the south-east corner. (The slight nature of the remains at Swarthy Hill should act as a reminder that not all the internal buildings may have been found during excavations on Hadrian's Wall milecastles.) It is possible that there were two distinct occupation patterns, one with a large number of men occupying buildings that took up most of the interior space, and one with just a small complement of men in a single small structure. These could reflect the dual purpose of the milecastles/fortlets with those near to important through routes serving more functions. Breeze & Dobson (1972, 189) have estimated a garrison of between eight and 32 on the evidence of the barrack blocks, but they also calculated that a minimum of 12 would be required to efficiently run the stations. Kinneil would fall into the first classification with a moderately large garrison, perhaps sufficient to warrant an officer as witnessed by the presence of Samian vessels. It is notable that at Wilderness there was no Samian from the 1400 sherds of Roman pottery recovered. Kinneil has also produced a shoe of very good quality suggesting a high status for its owner. At any rate it is clear that Kinneil held considerably fewer than the century of 80 men used in the more isolated fortlets such as Barburgh Mill (Breeze 1974).

PHASE II

The presence of external features at Kinneil was previously unsuspected and emphasizes the need to examine as large an area as possible in the investigation of these sites. Nonetheless, there is evidence for such features at a number of other fortlets. At Croy extensive traces of burning were found in a similar location. This included the remains of timber 'duck-boarding' burnt *in situ* (Hanson 1979, 19). Seabegs had a spread of cobbling overlying turf outside its north-east corner (Keppie & Walker 1981, 146). In both these cases the deposits were thought to be of a secondary nature, but their occurrence at Kinneil as well suggests that they may be associated with the initial occupation of the fortlets. Just what these areas were used for cannot be determined on the present data. If the large deep pit (Context 170) within the north-west corner at Kinneil is seen as a well, then there is an obvious lack of provision for latrines. This usage, however, would not explain the burning.

At a later stage at Kinneil access to this external complex was required from outside of the fortlet perimeter and was important enough to warrant the construction of a paved causeway over the partly backfilled ditch. The associated box drain (Context 257) may also lie on the line of this access route. Unfortunately, whatever it drained lay to the south and had been removed by subsequent tillage (Phase III). The stone dump (Context 254) provided communication from the through route across the curving ditch (Context 255). It is possible that another lean-to shelter occupied this corner using the ramparts as its north and west walls.

The layout of the fortlet underwent a drastic revision during the life of the Antonine Wall. Buildings 1 and 2 were demolished and a layer of stone and gravel spread over the north part of the interior. The distribution of this stone spread suggests that the two lean-to structures may have been retained, though with some modification (cf Biglands – Potter 1977, 160). The same appears to have occurred at Wilderness, with the two hearths being reused in a later phase (Wilkes 1974, 57 & fig 2). Secondary cobbling there also overlay the principal earlier buildings but the plan shows that the area behind the Rampart on either side of the new cobbling leading towards the gateway was still occupied by lean-to shelters. How far the cobbled area reached to the south is unknown. At both Kinneil and Wilderness the archaeological deposits which were not protected by the remnants of the north rampart have been removed. Near to the south limit of the surviving cobbling at Wilderness was a stone-lined culvert which passed across the interior from east to west and which may indicate that the extent was never much greater.

The origin of the clay below the cobbled surface at Kinneil may be significant. At the time of excavation it was thought that this might represent upcast from the digging of the demolition pit, but as this can now be seen as a well/latrine it is more probable that this layer was derived from the rampart core. If the ramparts had been demolished, then the causeway over the north end of the east ditch could have provided direct access to the lean-to shelters, replacing the Military Way. At Seabegs fortlet the turfwork previously noted as a potential foundation for a stair might alternatively be interpreted as demolished rampart material. In this context it is also interesting to note that the east/west culvert at Wilderness, mentioned above, cut through that fortlet's west rampart – a task that surely would have been avoided under normal circumstances. Although rather sparse, the cumulative evidence from the various excavated fortlets hints at the possibility that the south portions of these stations were demolished, the debris used to fill in the ditches (Wilkes 1974, 58). It is notable that at Kinneil a broken amphora was found in the upper ditch fill where it might suggest secondary occupation.

Perhaps the most intriguing area at this period is that of the north gate. Changes clearly took place here, but exactly what form they took is difficult to say. It would have been at this stage that any causeway across the great ditch was dug away. This process also occurred on Hadrian's Wall, where at least two of the turf wall milecastles, at High House and Randylands, had their causeways removed (Simpson, Richmond & St Joseph 1935). None of the remaining milecastles possesses a causeway. This phenomenon occurs at the other Antonine Wall fortlets, except that at Watling Lodge where a major road led northwards to the fort at Camelon. Access through the Wall to the north was now presumably restricted to the gates of the forts.

What happened to the fortlet gateways? At Seabegs, complete or partial blocking was suggested by a late extension of the south kerb of the Antonine Wall across the passageway. This had been laid on a thin layer of disturbed turf derived either from accidental slip or deliberate demolition. In the west half of the passageway heavy stones had been placed on top of the now disused road surface (Keppie & Walker 1981, 145). No such blocking material was found at Wilderness, but the secondary cobbling which gave access to this area stopped on line with the south end of the passage (Wilkes 1974, fig 2). A post-hole in the centre of the old road may belong to this phase, forming part of a timber screen wall. The evidence from Kinneil itself is slight and difficult to interpret. The box culvert (Context 133) appears to have run over the east line of post-holes associated with the tower, suggesting that the entire gateway, including the tower, was removed. The capped drain would then be similar to other Wall culverts, having been buried beneath the rampart when it was carried across the former gateway. Alternatively, however, it is possible that the gate passage was redesigned. It could, for example, have been reduced in width with the east side being moved closer to the west one, a common occurrence on Hadrian's Wall at the milecastles. Alternatively, the irregular gully

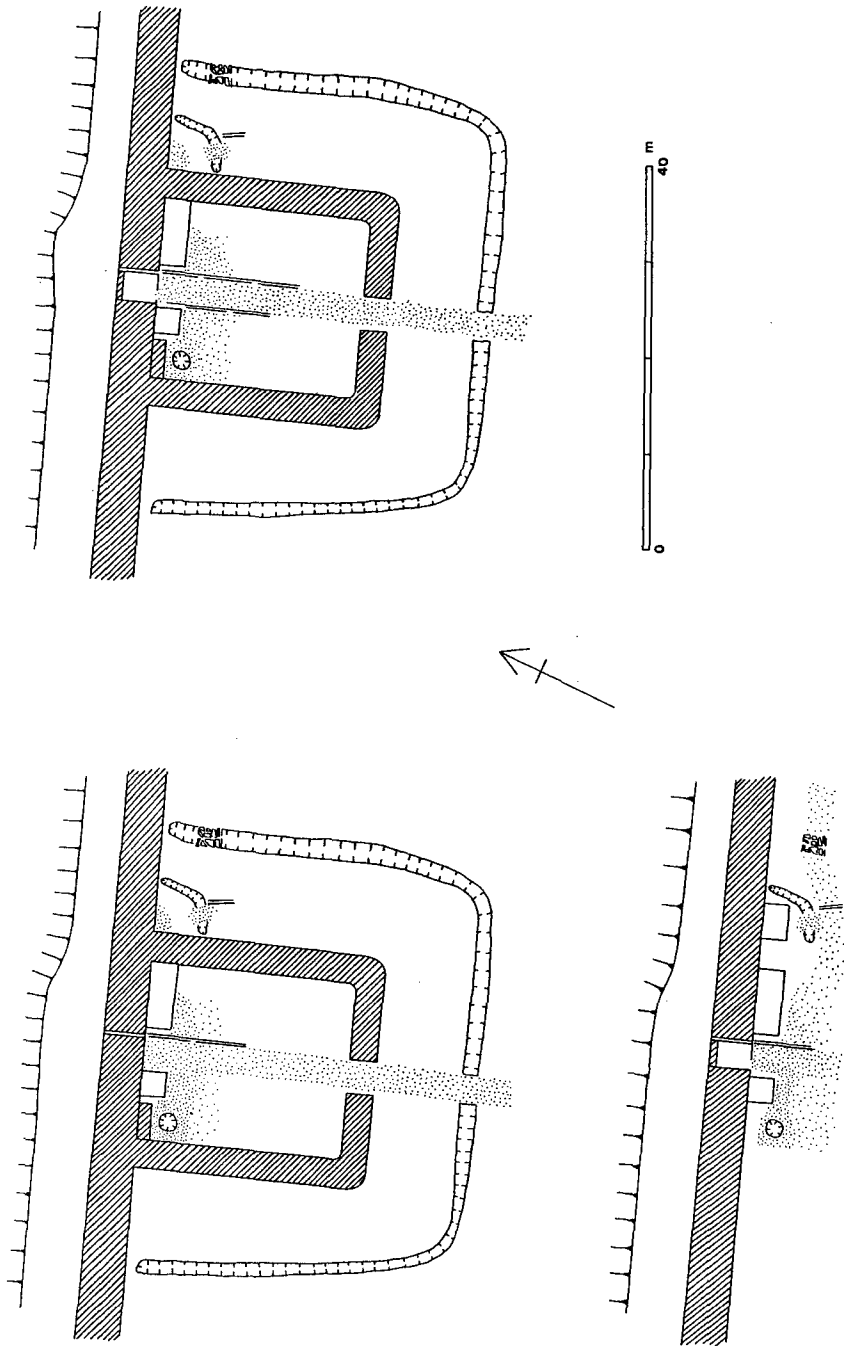

ILLUS 29 Three possible plans of Phase II based on the limited evidence of the excavation results

to the east of the new culvert could have housed replacement uprights for the tower, which might have been retained even if the gateway was not. In the latter case the burning on the road surface at this point may not be from the demolition work but from the reuse of the ground floor of the tower as a guard chamber. This would have been an easy modification, requiring little more than a wooden screen on the south side on line with the tower's uprights (cf Wilderness). The north side too would need to be blocked and the entrance concealed from that aspect by a clay or turf skin. This would at least explain why the secondary cobbling at Kinneil and Wilderness still gave access to this area.

While it is readily acknowledged that the evidence for this last scenario is slender, it is still useful to indulge in a little further speculation. If the north tower of the fortlet had formed part of a regular series of watch towers at 0.33 mile intervals along the Wall, as had been the case on its Hadrianic predecessor (see Bailey 1995), would it not have been retained even when the fortlet itself was decommissioned? In this case, the lean-to shelters would have provided accommodation for the reduced garrison in the same way as is suggested of a lean-to bothy at the Callendar Park watch tower (*ibid*). A down-grading from, say, 32 men to eight men might be envisaged with the change from a milefortlet to a watch tower.

Whatever the nature of the change, it could have resulted from the decision to construct the secondary forts of the Antonine Wall. Clearly the forts at Duntocher and Croy rendered the nearby fortlets redundant (Keppie & Walker 1981, 160). When the Antonine Wall was finally abandoned the milecastles on Hadrian's Wall were still reused and new ones built to replace those on the turf sector which had not already been rebuilt in stone. The turrets were also reoccupied (Breeze & Dobson 1987, 128). There the forts were more widely spaced and the subsidiary stations were evidently still required.

The excavation and interpretation of the fortlet at Kinneil provides further clues concerning the development of Roman linear frontier strategy. It is apparent that these barriers evolved during the course of their construction and that the Roman approach was quite flexible.

ACKNOWLEDGEMENTS

Falkirk Museum would like to thank the Manpower Services Commission for organizing the excavation, and the Parks Department of Falkirk District Council for help with the removal of the topsoil and the subsequent landscaping.

The pottery report is based on project work by undergraduate students of the University of Wales, Cardiff. P V Webster records his gratitude to T Ace, H Dick, S Russell, B Spurway, R Thornett, J Ward, A Warren and the editing team of D Cox, E Evans, R Johns, N Redvers-Higgins and W Weldon. P MacDonald helped with the supervision and computing.

The authors would also like to thank Dr David Breeze and Dr Lawrence Keppie for their comments on an early draft of this article.

REFERENCES

- Anderson, J 1903 'Leather', in Christison & Buchanan 1903, 341–2.
 Bailey, G B 1992 'Frontiers of knowledge: another look at the eastern end of the Antonine Wall', *Glasgow Archaeol Soc Bull*, 28 (1992), 6–8.
 Bailey, G B 1995 'The Antonine frontier in Callendar Park, Falkirk: its form and structural sequence', *Proc Soc Antiq Scot*, 125 (1995), 577–600.
 Bailey, G B forthcoming 'The Roman fort at Falkirk on the Antonine Wall', *Proc Soc Antiq Scot*.

- Barclay, G & Maxwell, G S 1991 'Excavation of a Neolithic long mortuary enclosure within the Roman legionary fortress at Inchtuthil, Perthshire', *Proc Soc Antiq Scot*, 121 (1991), 27–44.
- Bishop, M C 1986 'The distribution of military equipment within Roman forts of the first century AD', in Planck, D (ed), *Studien Zu Den Militargrenzen Roms III*, 717–22.
- Breeze, D J 1974 'The Roman fortlet at Barburgh Mill, Dumfriesshire', *Britannia*, 5 (1974), 130–62.
- Breeze, D J & Dobson, B 1972 'Hadrian's Wall: Some problems', *Britannia*, 3 (1972), 182–208.
- Breeze, D J & Dobson, B 1987 *Hadrian's Wall*. 3rd edn. London.
- Callender, M H 1965 *Roman Amphorae*. London.
- Charlesworth, D & Thornton, J H 1973 'Leather found in Mediobogdum, the Roman fort of Hardknott', *Britannia*, 4 (1973), 141–52.
- Christison, D, Cunningham, J H, Anderson, J & Ross, T 1898 'Account of the excavation of the Roman station at Ardoch, Perthshire, undertaken by the Society of Antiquaries of Scotland in 1896–97', *Proc Soc Antiq Scot*, 32 (1897–8), 399–435.
- Christison, D & Buchanan, M 1903 'Excavation of Castlecary fort on the Antonine Vallum', *Proc Soc Antiq Scot*, 37 (1902–3), 271–346.
- Curle, J 1911 *A Roman Frontier Post and its People: the Fort of Newstead in the Parish of Melrose*. Edinburgh.
- Davies, J & Spratling, M 1976 'The Seven Sisters hoard: a centenary study', in Boon, G (ed), *Welsh Antiquity*. Cardiff.
- Dore, J & Green, K 1977 *Roman Pottery Studies in Britain and Beyond* (=BAR Supp Ser, 30), Oxford.
- Forster, R H & Knowles, W H 1912 'Corstopitium: report on the excavations in 1911', *Archaeologia Aeliana*, 3rd ser, 8 (1912), 137–263.
- Frere, S S 1972 *Verulamium Excavations*. Vol I. London.
- Frere, S S 1992 'Roman Britain in 1991: site explored', *Britannia*, 23 (1992), 255–308.
- Frere, S S & Wilkes, J J 1989 *Strageath: Excavations within the Roman Fort, 1973–86*. London. (= Britannia Monogr Ser, 9).
- Gillam, J P 1970 *Types of Roman Coarse Pottery Vessels in Northern Britain*, 3rd edn. Newcastle upon Tyne.
- Gillam, J P 1976 'Coarse fumed ware in northern Britain and beyond', *Glasgow Archaeol J*, 4 (1976), 57–80.
- Hanson, W S 1979 'Croy Hill', in Breeze, D J (ed), *Roman Scotland: Some Recent Excavations*, Edinburgh, 19–20.
- Hinton, K A 1988 *Excavations in Southwark 1973–76, Lambeth 1973–79*. (= London & Middlesex Archaeol Soc/Surrey Arch Soc Joint Pub, 3).
- Hull, M R 1963 *The Roman Potters' Kilns of Colchester*. London.
- Keppie, L J F 1974 'The building of the Antonine Wall: archaeological and epigraphic evidence', *Proc Soc Antiq Scot*, 105 (1974), 151–65.
- Keppie, L J F 1975 'Leather', in Robertson, Scott & Keppie 1975, 59–91.
- Keppie, L J F, Bailey, G B, Dunwell, A J, McBrien, A H & Speller, K 1995 'Some excavations on the line of the Antonine Wall, 1985–93', *Proc Soc Antiq Scot*, 125 (1995), 601–71.
- Keppie, L J F & Breeze, D J 1981 'Some excavations on the line of the Antonine Wall, 1957–80', *Proc Soc Antiq Scot*, 111 (1981), 229–47.
- Keppie, L J F & Walker, J J 1981 'Fortlets on the Antonine Wall at Seabegs Wood, Kinneil and Cleddans', *Britannia*, 13 (1981), 143–62.
- Macdonald, G 1934 *The Roman Wall in Scotland*. Edinburgh.
- Macdonald, G & Park, A 1906 *The Roman Forts on the Bar Hill, Dumbartonshire*. Glasgow.
- MacGregor, M 1976 *Early Celtic Art in North Britain*. Leicester.
- Manning, W H 1966 'A hoard of Romano-British ironwork from Brampton, Cumberland', *Trans Cumberland Westmorland Archaeol Soc*, new ser 66 (1966), 1–36.
- Manning, W H & Scott, I R 1979 'Roman timber military gateways in Britain and on the German frontier', *Britannia*, 10 (1979), 19–61.
- Money, J 1977 *Fifth Interim Report on the Excavations in the Iron Age Hill-Fort and Romano-British Iron-working Settlement at Garden Hill, Sussex*.

- Oldenstein, J 1976 'Zur Aufrüstung römischer Auxiliareinheiten', *Bericht der Komisch-Germanischen Kommisschen*, 57 (1976), 49–284.
- Oswald, F 1936–7 *Index of figure types on Terra Sigillata, Supplement to Annals of Archaeology & Anthropology*. Liverpool.
- Padley, T G 1991 'The Roman shoes', in Padley, T G & Winterbottom, S *The wooden, leather and bone objects from Castle Street, Carlisle* (= Cumberland Westmorland Archaeol Soc Rep, 5), 228–43.
- Peacock, D P S & Williams, D F 1986 *Amphorae and the Roman Economy*. London.
- Potter, T 1977 'The Biglands Milefortlet, Cumberland', *Britannia*, 8 (1977), 149–92.
- Rhodes, D M 1980 'Leather footwear', in Jones, D M *Excavations at Billingsgate Buildings, Lower Thames Street, London 1974*. (= London & Middlesex Archaeol Spec Paper, 4), 99–128.
- Robertson, A S 1957 *An Antonine Fort, Golden Hill, Duntocher*. Edinburgh.
- Robertson, A S 1975 *Birrens (Blatobulgium)*. Edinburgh.
- Robertson, A S & Scott, M E 1980 *The Roman Collections in the Hunterian Museum*. Glasgow.
- Robertson, A S, Scott, M & Keppie, L J F 1975 *Bar Hill: A Roman Fort and its Finds* (= BAR Brit Ser, 16). Oxford.
- Simpson, F G & McIntyre, J 1933 'Banks Burn to Randylands', *Trans Cumberland Westmorland Archaeol Soc*, new ser 33 (1933), 262–70.
- Simpson, F G, Richmond, I A & St Joseph, J K S 1935 'The turf-wall milecastle at High House', *Trans Cumberland Westmorland Archaeol Soc*, new ser 35 (1935), 220–9.
- Stanfield, J A & Simpson, G 1958 *Central Gaulish Potters*. London.
- Steer, K A 1961 'Excavation at Mumrills Roman fort, 1958–60', *Proc Soc Antiq Scot*, 94 (1961), 86–132.
- Taylor, D 1982 'Excavation of a promontory fort, broch and souterrain at Hurly Hawkin, Angus', *Proc Soc Antiq Scot*, 112 (1982), 215–53.
- Tyers, P & Marsh, G 1979 'The Roman pottery from Southwark', in Bird, J, Graham, A H, Sheldon, H & Townend, P (eds), *Southwark Excavations, 1972–74*. (= London & Middlesex Archaeol Soc/Surrey Archaeol Soc Joint Publication No 1) 533–82.
- Webster, G A 1971 'A hoard of Roman military equipment from Fremington Hagg', in Butler, R (ed), *Soldier and Civilian in Roman Yorkshire*, 107–25. Leicester.
- Webster, G A 1982 *Rome Against Caratacus*. London.
- Wilkes, J J 1974 'The Antonine Wall fortlet at Wilderness Plantation, Lanarkshire', *Glasgow Archaeol J*, 3 (1974), 51–65.