

Excavations at Inveravon on the Antonine Wall, 1991

Andrew Dunwell* & Ian Ralston*

with contributions by Ann Clarke, Geraint Coles, Helen Crossley,
Brenda Dickinson, Bill Finlayson, Katharine Hartley, Nicola Murray,
Tim Neighbour, Alison Sheridan & Gordon Thomas

ABSTRACT

An excavation in advance of pipeline construction, sponsored by Shell Chemicals UK Ltd, has provided further information on the nature of the Roman military site on the east bank of the River Avon. The trench revealed that an expansion was the first structure abutted to the south of the Antonine Wall, and that this was subsequently replaced by a small fort. Ceramic evidence suggests that the majority of the structural remains that were identified within the ramparts of the small fort date to the final years of the occupation of the Antonine frontier.

INTRODUCTION

This report describes the results of the archaeological excavation by the Centre for Field Archaeology (CFA) of a 2 m wide trench in advance of pipeline construction through the small Roman military site on the Antonine frontier at Inveravon in 1991. During that year Shell Chemicals UK Ltd constructed the North-Western Ethylene Pipeline (NWEP) from Grangemouth, Central Region, to Stanlow, in Cheshire. Immediately to the south of the large petrochemical complex to the east of Grangemouth, the pipeline route intersected the Antonine frontier in low-lying ground on the east bank of the River Avon (NS 952798; illus 1). Here, the site of either a Roman fortlet or a small fort had been proposed on the basis of a spread of Roman remains previously identified by exploratory excavation (Robertson 1969; 1974).

The presence of a Roman fort in the Inveravon area has never been seriously doubted. The apparent regularity of spacing of forts on the Antonine frontier, and the necessity to guard the crossing of the River Avon, have long been recognized as compelling reasons for this. The choice of this location for the crossing of the river by the Antonine frontier was dictated primarily by topography: farther inland the steepness of the ravine, through which the River Avon passes, presents a considerable obstacle. A diversion of the frontier to the south in order to avoid this would also have detracted from the good views afforded by the chosen frontier alignment northwards across the Carse of Falkirk, to the Firth of Forth and beyond.

Early antiquaries appear to have located the fort erroneously at Inveravon Farm. Pont's observation, as cited by Sibbald, that along the Antonine frontier '... where there was a High near

* Centre for Field Archaeology, University of Edinburgh, 12 Infirmary Street, Edinburgh EH1 1LT

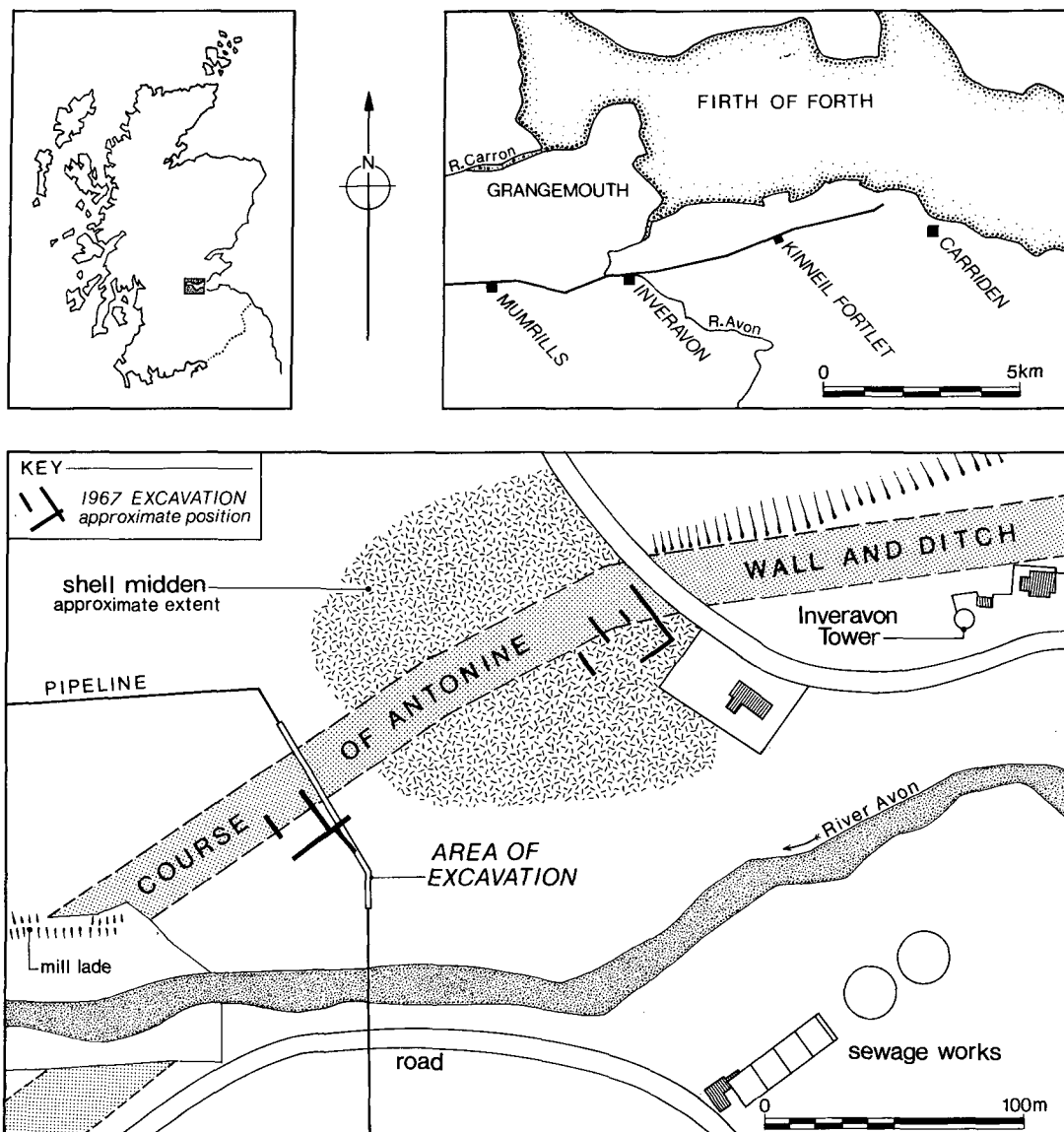

ILLUS 1 Location maps, including Robertson's trenches (in solid black) and Inveravon Tower

Water, there was ordinarily a Fort ...' (1707, 33), appears to have underpinned this belief. Sibbald reported that the site lay at '... Innevevin [now Inveravon Farm] where there hath been a Fort and the Ruins of Buildings remain yet ...', and that it was one of many Roman sea-ports on the southern shore of the Firth of Forth (1707, 30, 34). He subsequently mentioned '... at Inneravon, a Tower and the Foundations of other Buildings yet visible ...' (1710, 33). However, as Macdonald (1934, 193) recognized, Sibbald's comments clearly refer to the remains of a medieval fortification, of which Inveravon Tower (probably dating to the 15th century) represents a

surviving fragment. The Auchinleck Chronicle contains an entry, dated March 1455, which states that ‘James II kest down the Castell of Inveravyne ...’ (RCAHMS 1929, 188; no. 299).

Subsequent 18th-century accounts and commentaries appear to recognize, in some cases only implicitly, that the visible remains at Inveravon were not of Roman origin, but most continued to believe that this was the former location of the fort, of which no trace remained. Typical of these, Alexander Gordon reported of Inveravon ‘... the general Opinion is, that there was a Fort; but I could find no clear vestiges of it ...’ (1726, 60). To explain the absence of visible remains, General Roy thought that the site had been washed away by the river (1793, 154; 162), whereas Stuart (1845, 353) suggested that the ramparts of the Roman fort had been robbed for the construction of Inveravon Tower.

Whilst the presence of Inveravon Tower highlights the tactical strength of its location, solid evidence has yet to be produced for any preceding Roman occupation at that site. Excavations on the medieval fortification containing Inveravon Tower proved that ditches identified from aerial photographs were not of Roman origin (*Discovery Excav Scot* 1977, 38), and found no evidence for Roman occupation. Further circumstantial evidence against the suggestion that the site of Inveravon Tower previously had Roman occupation is provided by the absence of antiquarian records of appropriate finds from the location. This absence can be contrasted with Carriden, for example, where the fort site was a focus for later settlement; here, antiquaries (eg Gordon 1726) record a tradition of the discovery of finds of altars, inscriptions and coins.

Exploratory trenches dug in 1914 by Sir George Macdonald in order to define the course of the Antonine Ditch identified a change in the alignment of the frontier works on either side of the River Avon. He interpreted this as evidence that a small fort lay on the eastern bank of the river, where ‘... unmistakable, if indefinite, signs of occupation were noted ...’ (Macdonald 1934, 194). His trenches located spreads of stones, which were not those of the base of the Antonine Wall, both ‘near the river’ and ‘at the top of the field’, at a depth of about 0.6 m (1925, 271). Macdonald was circumspect about the date of these remains but recovered a sherd of mortarium from one of the trenches (1925, 272).

Macdonald’s suspicions were largely confirmed in 1967, when Professor Anne Robertson’s exploratory excavations revealed structures of Roman date, all traces of which had presumably been obscured and forgotten long before the 18th-century antiquarians became interested in the locality. Stone wall foundations and cobbled surfaces, representing two clear phases of Antonine occupation, were identified between c 145 m and 180 m from the eastern edge of the field (1969, 39–42; illus 1). Their poor preservation was attributed to erosion caused by the River Avon. Although the scale of Robertson’s work was insufficient to provide either a detailed ground plan of the remains, or, by not revealing its perimeter defences, the extent of the site, occupation evidence was recovered over an area of c 35 m east/west by c 27 m. In view of the absence of samian pottery in the finds assemblage, the remains, it was suggested, belonged to a small fort or fortlet which guarded the Avon crossing (Robertson 1974, 100–1). In apparent contrast to Macdonald’s results, further trenches excavated by Robertson at the higher, eastern end of the field revealed traces of the Mesolithic / Neolithic shell midden known to lie there (see below), but yielded no evidence of Roman occupation (information from unpublished plan held by the National Monuments Record of Scotland; illus 1).

More recent stray finds from this field have included box-flue tiles recovered from the vicinity of the river bank (*Discovery Excav Scot* 1973, 59; 1975, 61), from a hypocausted building, possibly a bath-house (Robertson 1990, 46). A concentration of worked stones, c 3 m wide, has been recorded on the bed of the River Avon at the point where the Antonine Wall is estimated to approach it from the east (*Discovery Excav Scot* 1973, 58). This has been very tentatively proposed as the foundations of a bridge or barrier (*ibid*), and as a ford (Hanson & Maxwell 1983a, 85). A bridge has been envisaged crossing the River Kelvin at Balmuildy, where worked Roman stones have been recorded on the river bed, although timbers have been dredged from the same site (*ibid*).

The uncertainties left by Robertson's results, combined with the low-lying position of the structures and the inability of aerial reconnaissance to locate unambiguous traces of a fort in the field, led to continuing speculation that a larger fort still awaited discovery on higher ground either to the east or west of the Avon gap (eg Robertson 1974, 101; 1990, 46). The growing corpus of evidence to support Gillam's hypothesis that a regular system of mile-fortlets was integral to the primary template for the Antonine frontier (Gillam 1976; Keppie & Walker 1981) gave qualified support to this argument by predicting that both primary fortlet and secondary fort could in fact be present around Inveravon (eg Hanson & Maxwell 1983a, 87, table 5.1 and 122, table 6.4; but cf. Keppie & Walker 1981, 161 where Polmonthill, to the west of the River Avon, was predicted as the location of 'mile-fortlet 05'). Maxwell's self-professed 'mischievous' suggestion that the sector of the Antonine frontier east of the River Avon is a secondary addition similar to the Wallsend to Newcastle sector of Hadrian's Wall (1989a, 163) cannot be dismissed, and might allow for an irregular distribution of forts and fortlets within this sector.

WORKING METHODS

The excavation at Inveravon represented the final stage of archaeological investigations conducted at the site. Aerial reconnaissance and geophysical survey were carried out during the planning stages of the NWEF Project in an attempt to define the extent of Roman remains and, if possible, to design the least destructive route for the pipeline through the field (Ralston & Armit 1990, 124–5), bearing in mind that it was known also to contain a substantial shell midden (MacKie 1972; *illus 1*).

Aerial reconnaissance was undertaken in fine conditions in July 1989. The results of this added little to that visible on photographs taken on previous occasions, principally by the Royal Commission on the Ancient and Historical Monuments of Scotland (RCAHMS): one of the 1989 photographs is presented here as *illus 2*. The line of the Antonine Ditch is clearly visible (*illus 2, A*), but no ditches surrounding a military establishment can be traced. An 'E-shaped' cropmark highlighted by Maxwell in the higher, eastern part of the field (1989b, 180, cf. *illus 2, B*) is of unknown origin; it comprises at least three unattached traces which are not necessarily contemporary or even of Roman origin. The mill-lade which served Jinkabout Mill, an ironworks, now destroyed, is visible as a distinct linear parchmark in the western part of the field (*illus 2, C*).

In October 1990 magnetometry and resistivity survey were conducted in a swathe up to 80 m wide around the proposed pipeline route by Geophysical Surveys of Bradford (1990). Various anomalies of possible archaeological origin were identified, although apart from the course of the Antonine Ditch, no archaeological remains relating to Roman occupation could be defined clearly. No ditch system for the inferred fort or fortlet could be traced.

Excavation took place during March–June 1991, after finalization of the route of the pipeline, and prior to its construction. The single trench was 84.5 m long and for the most part was 2 m wide (*illus 1*) – the bare minimum required for the insertion of the pipe. By agreement with Historic Scotland, the trench across the Scheduled area was hand-dug up to a maximum depth of 1.5 m below the modern ground surface, at which level the pipeline was to be laid. This restriction allowed all archaeological deposits (apart from the lower fills of the Antonine Ditch) to be excavated by hand to subsoil. Across the line of the Antonine Ditch a stepped trench, 3 m wide, was necessary to meet with safety requirements; at one point, with the permission of Historic Scotland, an area 5 m by 2 m was topsoiled, in order to clarify features exposed within the trench (eg *illus 3*). All work was conducted in line with conditions specified as part of the granting of Scheduled Monument Consent.

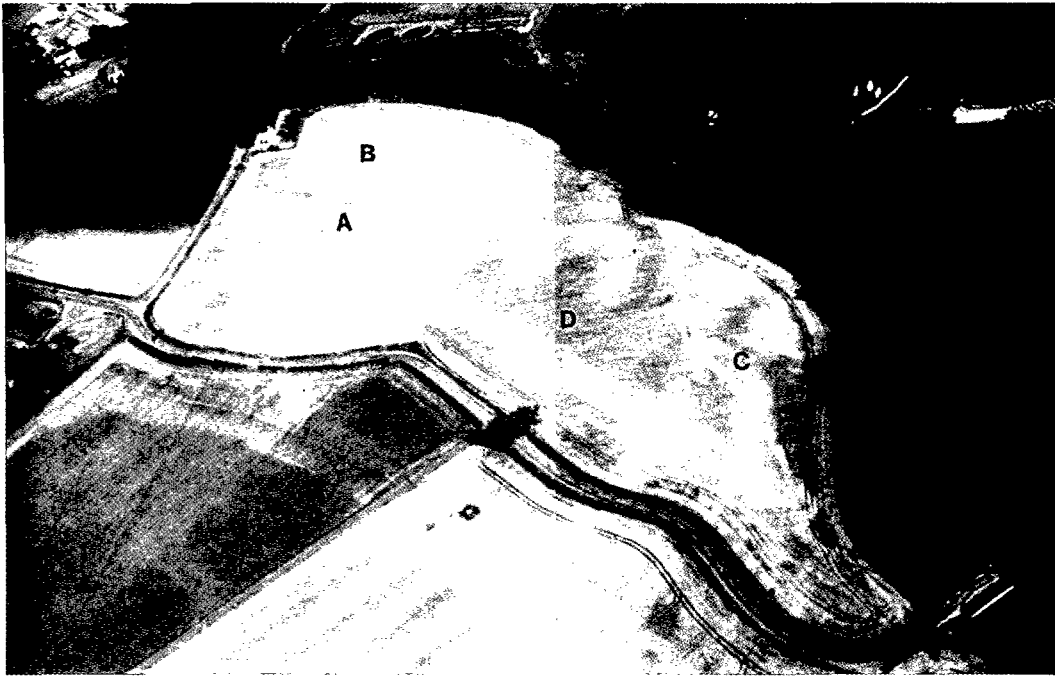

ILLUS 2 Inveravon from the air, 1989, looking south: the road was subsequently straightened and the land north of it developed as part of the petrochemical plant A: Ditch of the Antonine Wall. B: 'E-shaped' cropmark. C: mill-lade. D: darker crop (hillwash?)

After the completion of the excavation of the trench, a watching brief was conducted between its southern limit and the bank of the river. The examination of this sector revealed that no stratified remains were preserved above the subsoil. In addition, construction activities were carefully monitored to ensure that the pipe was laid within the excavated trench, and that no ground disturbance occurred elsewhere within the Scheduled area.

THE EXCAVATION

The trench lay in arable land beside the east bank of the River Avon, on the fringe of the Carse of Falkirk, at around 5 m OD (illus 1). The drift deposits of carse clay which cover this coastal zone were laid down by a major marine transgression around 6200 BC uncal (MacKie 1972, 414). The trench ran along the base of a moderate west-facing slope, referred to by Macdonald as a '... gentle declivity that spreads itself out to the sun ...' (1934, 194). This slope forms part of a series of raised beaches that overlooks the crossing of the River Avon from all sides but the north. Along these raised beaches a number of shell middens have been identified (eg Stevenson 1946; MacKie 1972); a Mesolithic-Neolithic shell midden, composed primarily of oysters and c 3 m deep, is seemingly confined to the higher ground within the field and to the east of the trench discussed here (MacKie 1972, 413–15; *Discovery Excav Scot* 1983, 2). Radiocarbon dates from this shell midden indicated a cessation of deposition in the third millennium BC uncal, when the sea is assumed to have receded (MacKie 1972, 414). The presence of this shell midden also presented a

significant archaeological constraint on the routing of the pipeline.) The precise position of the shore-line contemporary with the use of the Antonine frontier is unclear.

The trench location lies within a darker band visible on aerial coverage (illus 2, D). This tonal difference is presumably due to the accumulation of a greater depth of ploughsoil as a result of hillwash and of the downward movement of soil caused by cultivation; on the higher ground to the east, the buried shell midden probably contributes to the lighter tones recorded.

The narrowness of the trench requested by Historic Scotland inevitably constrains the interpretation, and potentially also the representativeness, of the results. Although the presence of buildings was established, little indication of their ground plan or function could be determined, and a number of minor features projecting into the trench defied interpretation. However, a detailed stratigraphic sequence, containing a number of securely stratified and closely dateable artefacts, was recorded. Archaeological deposits will survive outside the line of the excavation trench, and more extensive excavation would undoubtedly lead to the clarification of some matters unresolved by the present work and the identification of further complexities in the surviving deposits.

In the following account the stratigraphic phasing is employed as the primary organising element, with emphasis placed upon the description of the sequence of the interpretable elements. A detailed account of the stratification recorded during excavation is archived in NMRS (Armit & Dunwell 1992). Of the four phases of activity defined, the first three relate to Roman occupation. Phase 1 was defined by the construction of the linear elements of the Antonine frontier system and associated features. The construction of the defensive rampart and internal features of a small fort defines phase 2, with a subsequent reorganization of the internal layout marking phase 3. All post-Roman features are collectively grouped for the purposes of this report as phase 4.

PHASE 1: PRIMARY ELEMENTS OF THE FRONTIER (ILLUS 3)

Antonine Wall and expansion

The excavated section of Antonine Wall (or Rampart) was c 4.4 m wide and up to c 0.7 m high. Its carefully laid stone base, predominantly of millstone grit but including a few river cobbles, was preserved intact, and comprised roughly dressed kerbs containing a core of undressed blocks and chunks bonded by a stiff yellow clay. The millstone grit must have been quarried elsewhere and imported to the site, whereas the cobbles could have been obtained locally from the banks and bed of the River Avon. The stone core of the base of the Rampart contained very few overlapping stones, and generally comprised smaller and more densely packed material towards its centre (illus 4). Patches of millstone grit chippings sealed beneath the core may have been waste from the dressing of the kerbstones, which might suggest that the kerbs, having been dressed on site, were laid before the core material.

Positioned directly above the stone kerbs were c 0.3–0.4 m wide cheeks comprising blocks of turf and clay. These revetted a core of light brown gritty earth containing a small number of discontinuous turf lines (illus 5). The southern cheek was preserved up to 0.30 m high and was of complex construction; it included a mixture of apparently discrete, if distorted, blocks of clay and turf superimposed by bands of yellow clay (eg illus 5.2). The northern cheek survived no more than 0.10 m high and no trace of internal structure could be identified. The basic pattern of a predominantly earthen core revetted by cheeks of clay and/or turf is recorded in nearly all sections of the Antonine Wall excavated to the east of Watling Lodge, and was repeated at Inveravon (Keppie 1974, 156–7). Nearby, Robertson (1969, 40) identified a Rampart superstructure entirely of turf, providing possible evidence for lateral variation in composition in the immediate area.

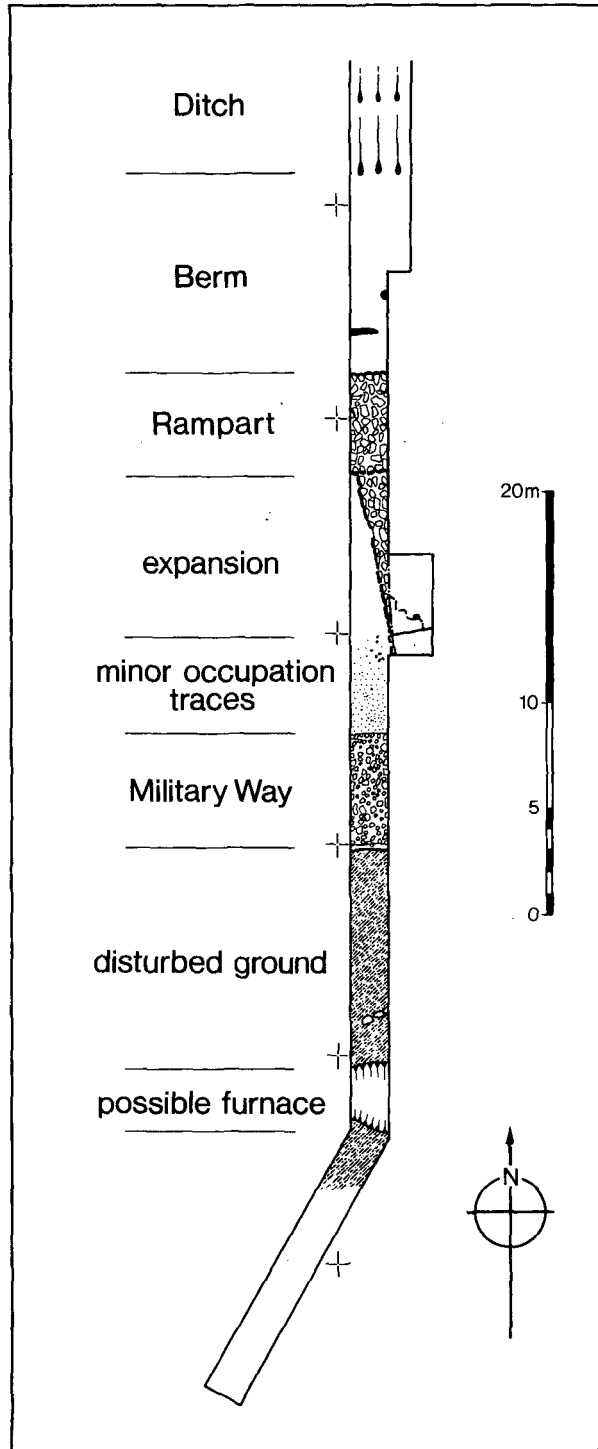

ILLUS 3 Summary phase 1 plan

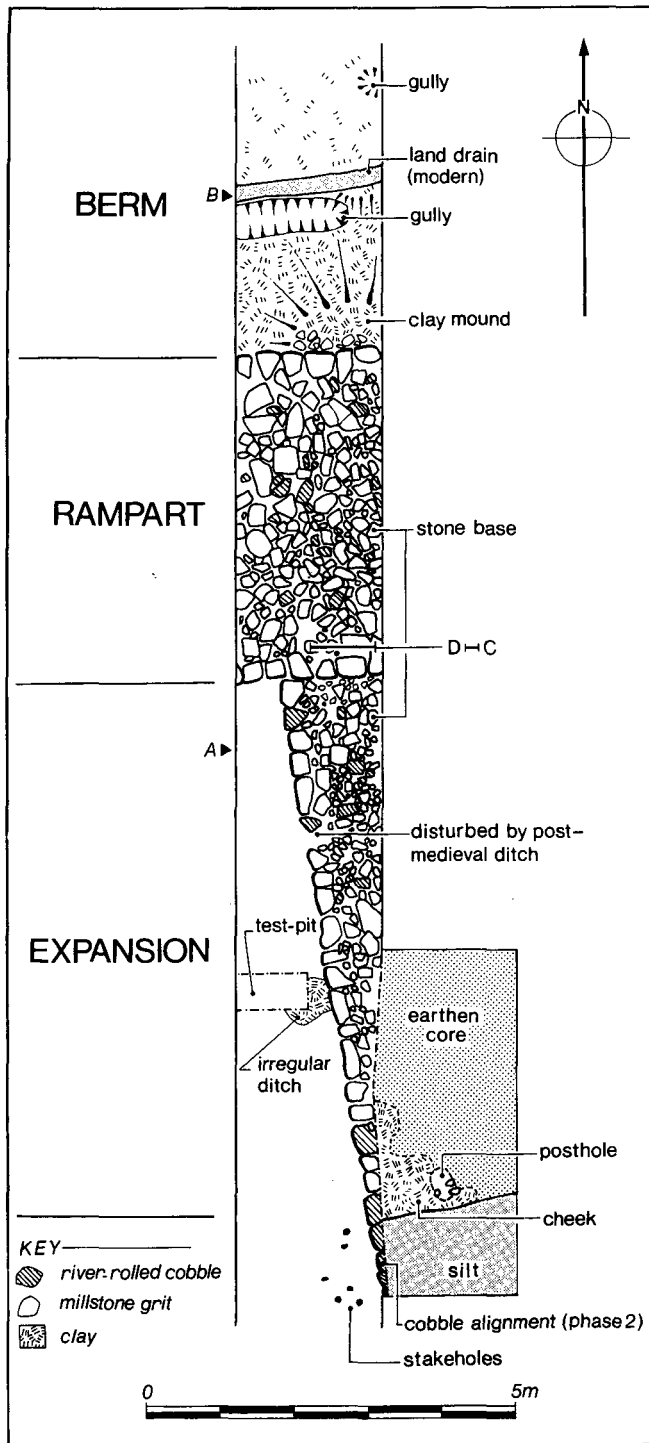

ILLUS 4 Plan showing the stone base of the Rampart and expansion, Berm, and associated features

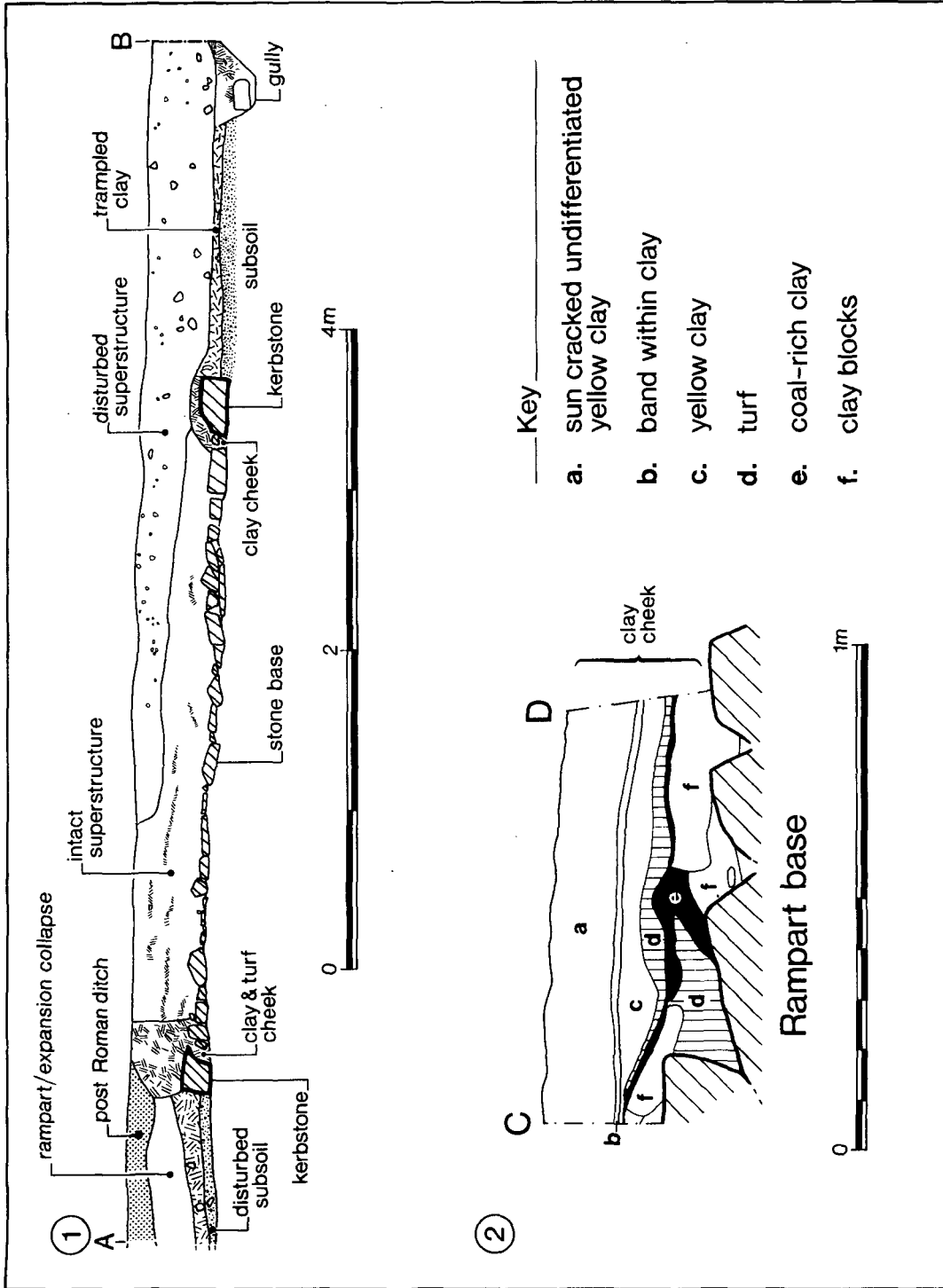

ILLUS 5 Sections through the Rampart and Berm (1, A-B) and along the inner face of the southern cheek of the Rampart (2, C-D). The locations of the sections are shown in illus 4

Rather fortuitously for such a narrow trench, the western side of an abutting construction was revealed immediately to the south of the Rampart (illus 4). The western side of this structure extended southwards for c 7.8 m, at an angle of 8–10° from the perpendicular to the alignment of the Rampart. This feature survived up to c 0.7 m high. As with the Rampart, it comprised principally a kerbed stone base supporting a superstructure of medium brown gritty earth revetted by a clay cheek up to 0.40 m wide. Its basal stone core, principally of millstone grit, comprised smaller stones than those revealed at the Rampart, and its stone kerb contained a small number of river-rolled cobbles. Slight depressions in the subsoil, no more than 0.10 m deep, appear to have been infilled with clay prior to the laying of the stone base. The surviving remains of the superstructure had been disturbed by the cutting of a shallow-sided ditch, c 3.5 m wide, of post-Roman origin (phase 4), the northern edge of which lay c 0.9 m south of the Rampart. The ditch had penetrated sufficiently deeply to have removed one of the kerbstones of the abutting structure.

The stone kerb of the Antonine Wall continued unbroken past its junction with that of the abutting feature, with the implication that the latter was a secondary construction (illus 4, 7). However, the cheeks of the two structures may have been bonded at their junction, as turf lines within the expansion overlapped the kerb of the Rampart (illus 6). The cheek surmounting the southern kerb of the Rampart was continuous, and served to separate the earthen cores of the two structures.

On the initial exposure of the clay cheek of the abutting structure, and before the realization of its full significance, topsoil had been removed from an area of 5 m by 2 m adjacent to where the clay cheek ran into the eastern edge of the trench. This revealed that the clay cheek returned abruptly eastwards, a feature which was subsequently recognized as defining the southern side of the abutment (illus 4). Although plough damage had sufficiently disrupted it to preclude determination of its precise alignment, this southern side did not appear to run parallel with the Antonine Wall. A post-hole measuring 0.40 m by 0.20 m in plan was identified within this clay cheek, possibly indicating that it had at some time contained a timber upright using the stone kerb beneath as a post-pad. Excavation of this feature was not undertaken because of the constraints of the Scheduled Monument Consent.

Of the structural forms identified to date along the Antonine frontier, the characteristics of this abutting construction most resemble those of an ‘expansion’. Only six such structures have previously been identified on the Antonine frontier, occurring in pairs at Tentfield Plantation, Bonnyside, and Croy Hill. Only one, Bonnyside East, has been investigated in detail (see Steer 1957 for discussion and gazetteer). However, the recorded width of c 7.8 m for Inveravon is substantially larger than the 5.5 m maximum demonstrated by excavation at Bonnyside East and Croy Hill East, and inferred from antiquarian accounts of Tentfield West (Steer 1957, 169). Furthermore, the only detailed ground plan recorded, at Bonnyside East, was square. The exposed fraction of the Inveravon structure indicates clearly that it does not have a square ground plan. It is not unreasonable to extrapolate on the basis of the available evidence that the Inveravon example exhibited a broadly trapezoidal ground plan, of unknown width. Only further excavation could elucidate this.

In the angle formed between the Rampart and the expansion, a mound of material up to 0.45 m deep and very similar in composition to the earthen core of the adjacent structures extended southwards from the Rampart for c 7.5 m before petering out. (The material occupied the excavated area surrounded by the three stone features on illus 7, and continues beneath the stone feature in the background, see below; see also illus 12.1.). This substantial deposit overlay a layer of stiff mottled yellow and medium brown clay extending for c 6 m from the Antonine Wall. It is tempting to see these successive layers as representing material redeposited from the clay face(s) and earthen core(s) of the adjacent structure(s). They may represent an episode of collapse, with the clay cheek shearing off from the earthen core, to be rapidly followed by a quantity of destabilized core

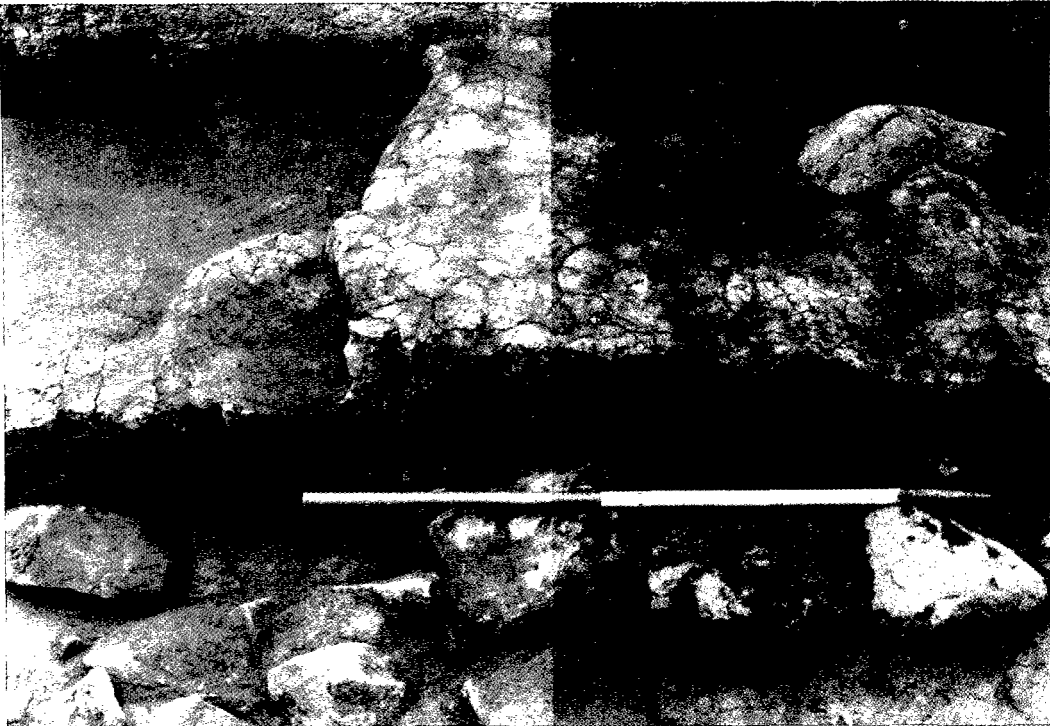

ILLUS 6 Section of the junction of the cheeks of the Rampart and expansion, looking east

material. Alternatively, the excavated deposits could be the result of deliberate slighting of the structure(s). It would be unwise to speculate further on the basis of the available evidence, and the exposure of more extensive areas might have allowed further explanations to be proposed. Whatever their mode of deposition, the stratigraphical position of the two layers indicates that they were clearly laid down before features associated with the occupation of the small fort (illus 7), demonstrating the fort to be a secondary addition to the frontier at this point. There is nothing to suggest that these layers related to activity preceding the Roman presence at the site.

Partly sealed beneath this putatively collapsed material, an irregular arrangement of six stake-holes and a patch of burnt organic matter were identified adjacent to the south-west angle of the expansion (illus 4). In addition, a thin patchy layer of mixed occupation debris ran northwards from the Military Way and underlay the collapsed material. Whilst no dating evidence was obtained for these features, their stratigraphical position indicates that they may be associated with the presence of the expansion.

Berm (illus 4, 5 & 8)

The Berm was 9.20 m wide and sloped gently down towards the southern lip of the Ditch. Its uneven surface, defined by the gritty subsoil, was covered with a mixed clay deposit for a distance of up to 3.80 m northward from the Rampart; this clay was no more than a thin smear in places, but where it filled depressions in the subsurface it was up to 0.15 m deep (illus 4). The clay may



ILLUS 7 The junction of the stones bases of the Rampart (foreground) and expansion, looking south. The phase 2 rough stone surface in the northern range is in the background: the material beneath it is collapsed phase 1 material

represent trampled waste material from the construction of the Rampart; it did not appear to be a laid clay flooring. Abutting the northern kerb of the Rampart in the east side of the trench was a distinct mound of stiff clay, up to 0.35 m wide and 0.15 m thick, containing small cobbles (illus 4 & 8). The origin of this deposit is not known; it may also be construction waste, although no cobbles of this size were incorporated within the adjacent structures.

Two features of particular interest were identified on the Berm. A steep-sided elongated pit or gully, with a rounded terminus and a level base, projected eastwards into the trench c 1.6 m

north of the Rampart. It had an exposed length of 1.35 m, and was c 0.4 m wide and slightly more than 0.3 m deep (illus 4 & 5). Its fill comprised lumps of brown, orange, blue and grey clay and cobbles, set within a dark brown clayey soil. The terminus of a second feature, probably of similar type, projected westwards into the trench c 3.3 m north of the Rampart (illus 8). This was 0.55 m wide and 0.25 m deep, with steep sides (the southern apparently disturbed) and an uneven base, and was filled successively by charcoal-rich silt and yellow-orange clay.

It could not be determined whether these features were primary components of the Antonine frontier or were secondary additions associated with the construction of the fort. The southerly example was cut through the spread of mixed clay on the Berm (illus 5), suggesting that these features were not excavated until after the construction of the Rampart. It seems most likely, however, that they were deliberately filled only when the fort was finally demolished, as their fills contained a range of finds including fragments of brick, vessel glass, and an iron nail.

Features with similar characteristics, termed 'defensive pits' by Bailey, have recently been located on the Berm at other locations on the Antonine frontier, such as Callendar Park (*Discovery Excav Scot* 1990, 8; Bailey 1992, 8), although here more densely spaced, and Garnhall (Burnham *et al* 1993, 279), and their presence may be widespread. Their precise nature and function are matters of conjecture, but their context suggests that a broadly deterrent purpose is likely. No evidence was found in the base of either example for the emplacement of upright posts or stakes, which might indicate an origin as *lilia*. The difference in spacing and profile between the features at Inveravon and the *lilia* to the north of Rough Castle fort (Buchanan *et al* 1905) is, however, striking. The Inveravon examples were sealed beneath collapsed earthen core material from the Rampart and are thus unlikely to have been substantially truncated. Further discoveries are necessary for a fuller understanding of the distribution and function of these features.

Ditch (illus 8)

Only the upper 1.15 m of the Ditch fills were excavated, as deposits below this depth would not be damaged by the pipeline. Thus only the upper part of its secondary, semi-waterlogged, clay fills were removed. Its profile was broadly symmetrical, with an upper shallow gradient of 20–30° from the horizontal giving way to steeper sides at a depth of around 0.6 m below its preserved surface. The Ditch had a surface width of approximately 8.2 m, although its upper edges were not sharply defined, decreasing to c 5.5 m at the change in gradient (illus 8). The Ditch was sealed beneath a thick accumulation of buried ploughsoil, containing medieval and post-medieval pottery, which extended in both directions from the Ditch – thereby partly sealing the Upcast Mound to its north and the collapse from the Rampart onto the Berm to its south.

Coring conducted by Dr Geraint Coles suggested that the Ditch had a total depth of c 2.5 m. The precise determination of this figure was severely hindered by the buttery nature of the laminated carse clays through which the lower part of the Ditch had been cut (illus 8). These carse clays appeared to have been washed in with grit derived from the subsoil above them to form its primary fill. The excavated clay subsoil is likely to have been used as the raw material for constructing the clay cheeks of the Rampart and expansion.

Upcast Mound (illus 8)

The truncated remains of the Upcast Mound, 12.5–13 m wide, lay c 2.7 m north of the Ditch, and survived up to 0.8 m high. It is unclear whether the gap between the Ditch and the Upcast Mound was a deliberate design feature; either the southern edge of the Upcast Mound had lain closer to

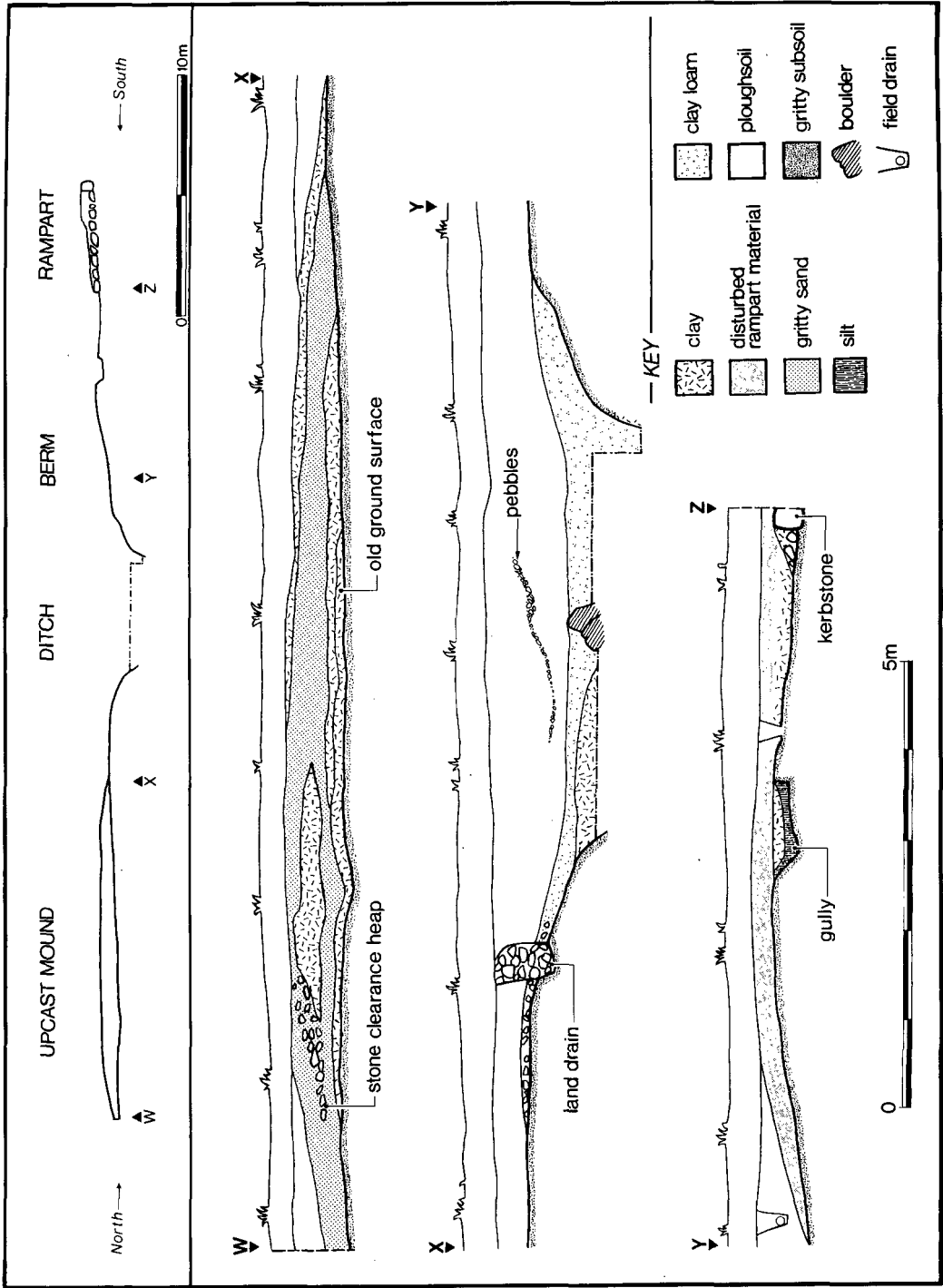

ILLUS 8 Composite section of Berm, Ditch and Upcast Mound

the Ditch and had slipped into it, or the alignment of the southern edge of the Upcast Mound was preserved, and had been constructed back from the edge of the Ditch to avoid such slippage problems. The northern edge of the Upcast Mound was not clearly defined, although a band of cobbles running east/west across the trench may have been dumped against the northern side of the Upcast Mound, at that time upstanding, and may have derived from a subsequent episode of stone clearance on adjacent cultivated land. There was no evidence for a formal boundary on either side of the Upcast Mound.

The principal components of the Upcast Mound were a coarse, gritty soil very similar in texture to that cut through by the upper part of the Ditch, and a light brown, stiff clayey soil. A heavy clay layer at the base of these deposits may be the remains of a buried ground level, although no turf-line was evident. Beneath the Rampart and expansion no such layer was present, and it may be that here the topsoil had been stripped prior to their construction. That turf was present prior to frontier construction is suggested by its incorporation within the Rampart (recorded also by Robertson 1969).

Military Way (illus 9)

The Military Way ran c 13.2 m south of the Antonine Wall and c 5.4 m to the south of the expansion. In its original form, prior to its modification with the construction of the buildings to either side of it, the road was of simple construction, comprising a c 5.2 m wide cambered surface of pebbles set on a cobble foundation. There was no evidence that it was flanked by ditches. Its surface had been damaged towards the centre by previous archaeological excavations.

PHASES 2 & 3: A SMALL FORT

At some stage after the apparent collapse of the Rampart and/or expansion, a small military site was constructed. The remains are interpreted on present evidence as those of a 'small fort'; the reasons for this are given below (see Discussion). As identified by the work reported here, the small fort was defended by a single rampart. No evidence of an external ditch system was recorded by the watching brief conducted during the cutting of the pipe trench between the southern end of the excavated trench and the bank of the River Avon. The small fort had a north/south dimension of c 34.5 m between the ramparts. The interior arrangement appears to have been of simple bipartite form, with the Military Way, although modified from its original configuration, continuing to act as the main east/west thoroughfare. This road divided the interior into two ranges, here termed north and south. Two distinct structural phases were identified on either side of this road (phases 2 & 3; illus 10). Ceramic evidence suggests that their occupation must date to AD 155–160 at the earliest. The residual traces of a possible iron-smelting furnace were sealed beneath these two phases in the southern area (illus 13), but it is unclear whether this feature lay within the small fort (phase 2) or predated its construction (phase 1).

Detailed consideration of the structural development of the north and south ranges, and southern rampart, are given in the following sections. No stratigraphic links were preserved between deposits on either side of the central roadway, although the similarity between the phase 3 structural remains and finds assemblage on either side of the road allows the two sequences to be reasonably matched. Definitive interpretation of the phase 2 remains was hindered both by the narrowness of the trench and by disturbance associated with later



ILLUS 9 Military Way, looking north: the phase 2 construction trench lies in the right foreground, with the phase 2 rough stone surface in the background

rebuilding. The phase 2 building identified was orientated east/west, parallel to the alignment of the Military Way and fort defences, whereas the phase 3 structures replacing it were aligned NNW/SSE (parallel to the exposed alignment of the phase 1 expansion). There was no evidence for an abandonment of the site between the two phases. With this rebuilding, the Military Way ceased to function in its original form. It was narrowed on both sides, and surfaces branched off to the north and south. On final abandonment, the buildings within the fort were demolished and the remains burnt.

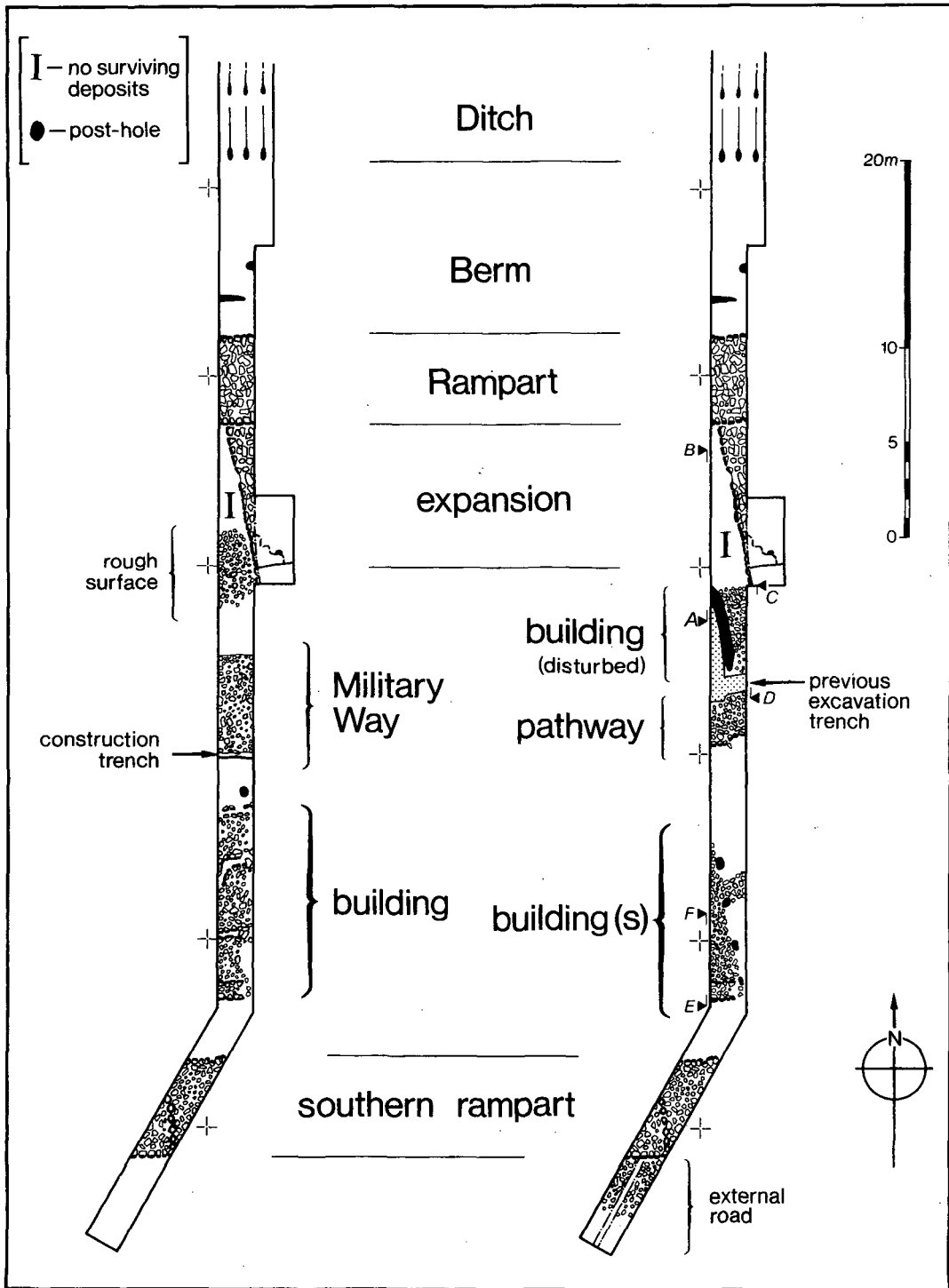

ILLUS 10 Phase 2 (left) and phase 3 (right): summary plans

Northern range

The nature of the phase 2 remains present in the northern range cannot be adequately interpreted on the basis of the excavated sample, although a complex sequence of deposits was observed. However, there was no evidence to suggest that a building lay in this area at this time.

All remains associated with the fort which once lay above the phase 1 expansion / Rampart collapse material, within c 7 m of the Rampart, had been truncated by ploughing (illus 10). Located c 2.5 m north of the Military Way was a c 3 m wide rough inclined stone arrangement (illus 11) set within a matrix of compacted gravel, which was in turn laid upon a series of uninterpretable silty earth and turf deposits, possibly associated with the rampart/expansion collapse (illus 12.1). This stone surface rose up northwards over the phase 1 collapse material and was truncated where its level met that of the ploughsoil, and abutted the western face of the expansion. It appeared to comprise two adjacent bands of millstone grit and river-rolled cobbles, although no formal division could be identified between the two (illus 11.1). A pebble-rich layer both between and above these stones may be the degraded remains of a surface above the stone arrangement.

The northern edge of the Military Way appeared to have been marginally truncated by a shallow, steep-sided cut (illus 11). The slight hollowed effect created between the surface and the Military Way was partly infilled by a thin layer of occupation waste and subsequently by a series of minor earth and stone dumps (illus 12).

As a result of plough truncation, excavation could not establish how the expansion was reused after the construction of the small fort. No fresh construction directly overlay it, and the phase 2 deposits respected its alignment. The balance of available evidence therefore suggests that the expansion was still standing above the floor level of adjacent buildings and roads, which had been laid out around it. The alignment of the western kerb of the expansion was extended southwards, and this feature was also respected by identified phase 2 deposits. Only three cobbles of this alignment lay within the trench, but they were noticeably smaller than the material forming the kerb of the expansion (illus 4 & 10). Although these observations conceivably provide evidence that the expansion was incorporated within a rampart, the absence of a clay cheek above the cobbles would be atypical of the construction techniques observed at the site and is contrary to the evidence of the southern rampart (discussed below). In view of the very partial exposure of this feature, it is difficult to propose a convincing interpretation of its function.

In the northern range phase 3 was marked by the construction of a cambered road in the eastern half of the trench (illus 11). This was 4.2 m long and overlapped the northernmost 1 m of the Military Way (illus 10 & 12.2). Its compact pebble surface, 0.10–0.15 m thick, lay upon a foundation dump predominantly of millstone grit chunks which infilled the preceding hollow. Its north and west edges were well defined, but its south margin was represented by a decreasing density of pebbles. To the north of the road any contemporary features had been removed by ploughing. A building probably lay in the area enclosed by these reshaped surfaces, although any structural remains had been removed by a previous excavation trench (illus 11). A cluster of stones preserved in the base of the old excavation trench may have been the residual remains of a stone wall. A shallow gully up to c 0.6 m wide and c 0.1 m deep, possibly a drip trench, ran along the edge of the road and may indicate the former position and approximate alignment of the wall of an adjacent building. At one point the gully contained a dense spread of over 600 amphora fragments derived from a single vessel (illus 11.3): their extent was restricted and they were not part of a path surface (cf Camelon, where this use of amphora fragments is recorded; Maxfield 1979, 31).

Robertson's excavations may hold the key to the identity of this building. A fragment of

stone foundation is identified in one of Robertson's mapped trenches running east/west; this appears to correspond with a previous excavation trench located during excavation (illus 1, cf illus 10, cf Robertson 1969, 41, fig 3). If this association is correct, this would imply that a stone foundation lay a short distance west of the 1991 trench. As this trench ran along the axis of the Military Way, the building must have been constructed after the Military Way ceased to function in its original form, which the 1991 excavation suggests to have been with the phase 3 reconstruction. The stone foundations identified by Robertson may therefore provide a structural context for the phase 3 remains identified in 1991 in the northern range.

The excavated road and gully were sealed beneath a spread of mottled yellow clay containing a substantial number of cobbles, and subsequently a silty earth containing quantities of amphora sherds (but of a different fabric from that recorded within the gully) was laid down (illus 12). This latter deposit relates to the demolition of the fort, although the origin of its material could not be determined.

Southern range

Between the Military Way and the southern rampart three discrete structural phases were identified. The earliest comprised the fragmentary remains of a structure which artefacts indicate to have been an iron-working furnace (illus 3 & 13). The most tangible structural element was a slight and irregular linear depression: this was up to 3.0 m wide and 0.1 m deep, orientated east/west and contained a spread of charcoal-rich burnt debris (illus 13). Two patches of cobbles lay above this material, the northern extending over the northern lip of the depression, and these were in turn sealed beneath a burnt spread of similar composition to that within the depression. Similar depressions were recorded at the Roman iron-smelting furnace site of Byfield and Laxton, Northamptonshire, although their contents were substantially different to those at Inveravon (Jackson & Tylecote 1988). A mound of earth was deposited over these remains, probably after the disuse of the furnace and the partial demolition of any associated upstanding structural remains. This mound extended northwards to an arc of three boulders, which lay c 1.8 m from the depression and marked the northern limit of surviving activity associated with the furnace (illus 3).

The upper burnt spread and succeeding mound both contained quantities of coal, iron slag and possible furnace lining. The occurrence of these materials on the site was heavily concentrated within these two deposits, implying that they were related to the function of the excavated features, rather than incidentally introduced. An Antonine date for the putative furnace was indicated by the Black Burnished Ware recovered from associated deposits. These deposits did not extend as far as the southern rampart, which lay less than 3 m away, and no stratigraphic relationship was identified. The depression was cut into the heavily disturbed subsoil, containing lenses of charcoal, which extended northwards for c 10 m towards the Military Way. A stamped, plain, transitional Dr. 18/31 – Dr. 31 samian dish was recovered from within this disturbed subsoil a short distance north of the boulder arc. Its date of AD 155–160 provides a *terminus post quem* for the subsequent structural phases.

At some time after the putative furnace fell into disuse, and not before AD 155 on the basis of ceramic evidence, a substantial building was erected in the southern part of the small fort. This possibly measured as much as c 13 m north/south, and fronted on to the Military Way (illus 10 & 13). Its form and function could not be established from the limited sample excavated.

Its southern end comprised a substantial cobble foundation, some 9 m wide and 0.25 m thick, within which discrete lateral variations in composition suggested the dumping of separate loads of material (illus 14). Both the boulder alignment and the uppermost earthen mound associated with

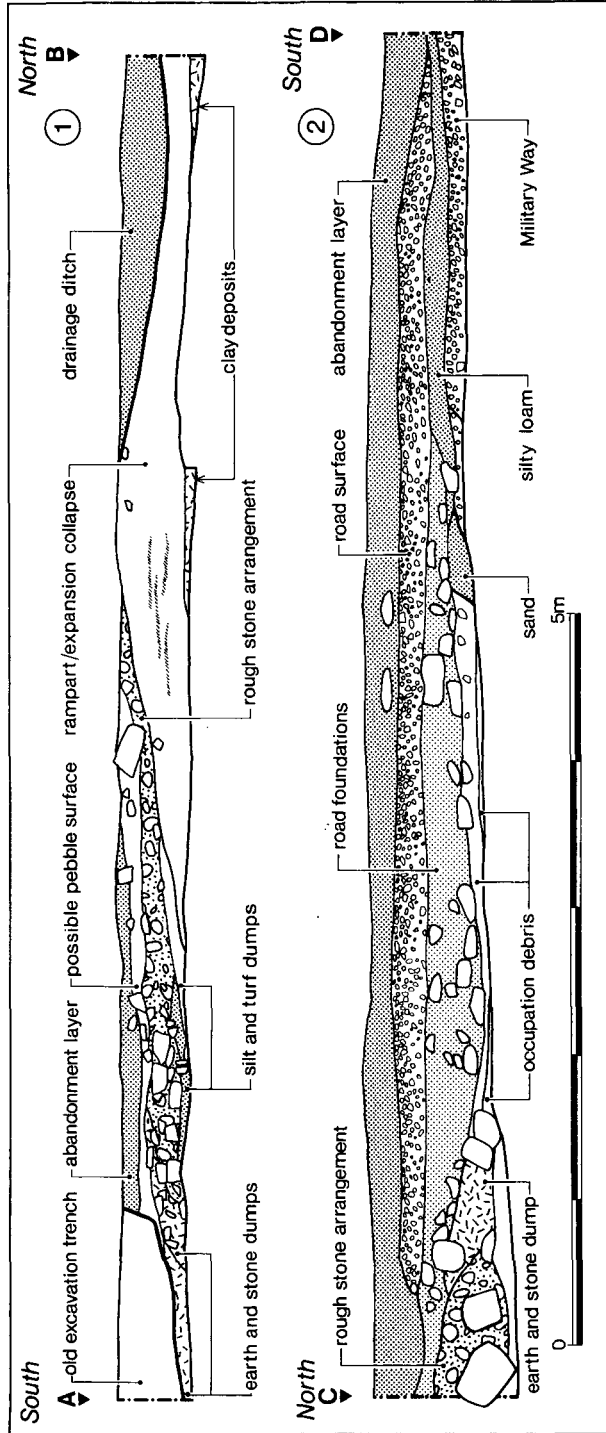

ILLUS 12 North range, sections A-B and C-D (locations in illus 10)

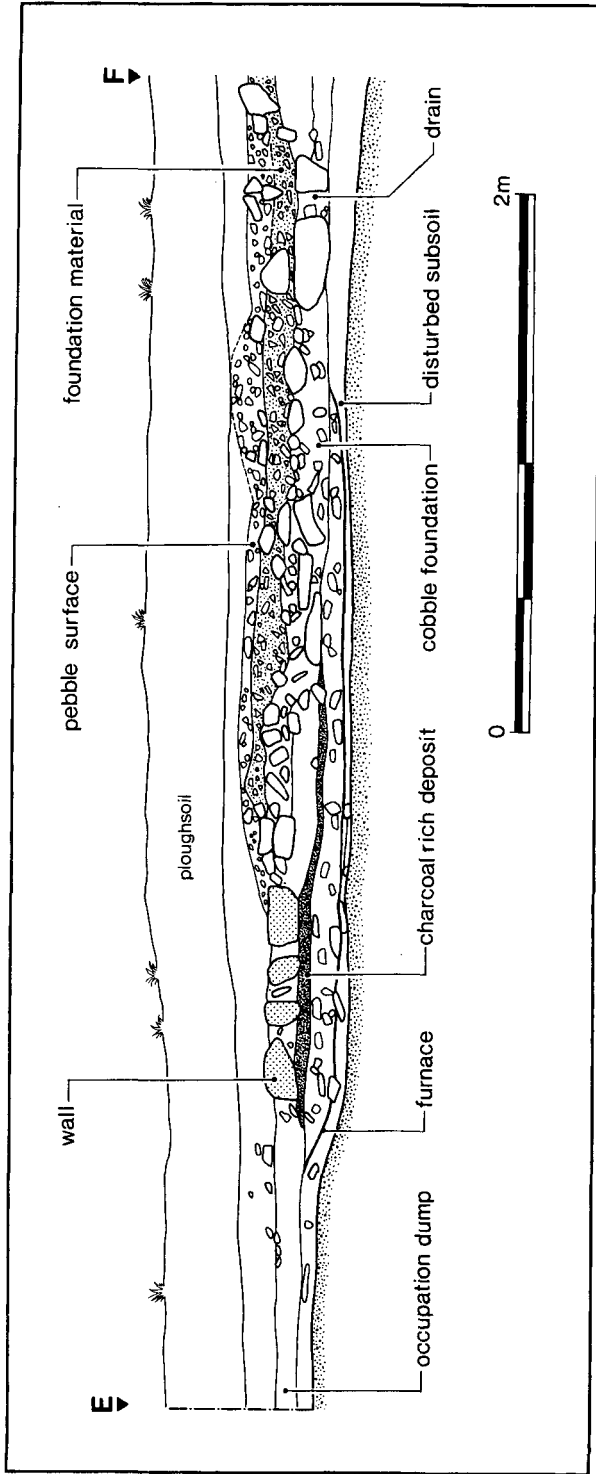

ILLUS 13 South range, section E-F (location in illus 10)

the demolished furnace had been incorporated within the foundations, although quite why this was so in the latter case is a mystery. Patches of a denuded pebbled surface lay on top of these foundations. Two stone-lined, but not floored, drains, each c 0.2 m wide, ran through the foundation from east to west, one with a distinct bulge to the east, and the other turning south-west to the west, possibly indicating that it fed into the former. A single capstone survived *in situ* above each drain and was visible through the pebbled surface. It may be that this part of the structure was a courtyard.

These substantial foundations were bounded to the north by a third, poorly preserved, stone-lined linear drain of similar dimensions, and to the south by the truncated basal course of a millstone grit wall which lay c 3.5 m from, and ran parallel to, the southern rampart (illus 14). This wall was 0.6 m wide and comprised roughly dressed faces and a core of stone fragments. Its characteristics were the same as those identified by Robertson's excavations (1969, 40 & fig. 3).

The northern side of this building did not appear to be formed by an equivalent stone wall, unless all trace of it had been removed by subsequent construction. A squared slot, which ran parallel to the alignment of the southern wall foundations and lay immediately beside the southern edge of the Military Way, most probably represents its position (illus 9 & 10). It was of a size (up to 0.25 m wide by 0.20 m deep) compatible with an interpretation as a foundation trench for a timber superstructure, and was stratigraphically contemporary with the stone foundations to its south. No post-impressions were identifiable in its base, but evidence is insufficient to propose specifically either a sleeper beam or a post-trench construction technique. The generic term 'construction trench' (cf Hanson 1982) is thus proposed. A single post-hole represented the only contemporary structural activity present in the area between construction trench and cobble foundation.

Prior to the phase 3 rebuilding, the drains within the cobble foundation appear to have fallen into disuse, their channels choked with gravelly and clayey silt fills, and their capstones removed. A thin layer of occupation or demolition debris lay upon the pebbled surface and overlay the exposed fills of the drains. The assemblage of pottery associated with this building is very restricted in range, comprising only mortaria and domestic cooking vessels. A sherd of mortarium recovered from the floor deposit, where sealed beneath the phase 3 foundation, is of a type thought to post-date AD 155. No phase 2 floor levels or occupation deposits survived between the cobble foundation and Military Way. A series of dumps of occupation material present between the southern wall and the southern rampart may be associated either with the phase 2 structure or the phase 3 rebuilding. On its replacement, there was no evidence from the deposits or artefacts that the phase 2 building had been burnt.

With the phase 3 rebuilding the Military Way was narrowed on its southern side by c 0.6 m, resurfaced to incorporate a roughly paved walkway, and provided with a tightly fitted cobble kerb (illus 10 & 15). A large piece of a possible two-sided stone gaming board was dropped on this surface and, once reduced to fragments, was subsequently trampled in. The partial survival of the kerb is most probably the result of subsequent demolition. A worm-sorted layer of sandy soil on average 0.05 m deep lay on the road surface and was rich in small pottery sherds and iron hobnails, including one cluster in the form of the sole of a boot or shoe.

To the south of the narrowed Military Way the phase 2 building was demolished, but its cobble foundation was retained. At least one post-built, half-timbered building, flanked by a road surface, was built on this foundation (illus 10, 14 & 16). An alignment of four post-holes represented the western wall of the building(s). The uprights formed two pairs each c 2.0 m apart, separated by a distance of c 2.4 m. The base of the southernmost post contained a stone-lined post setting 0.15 m square, which may indicate the thickness of the posts inserted. The adjacent exterior

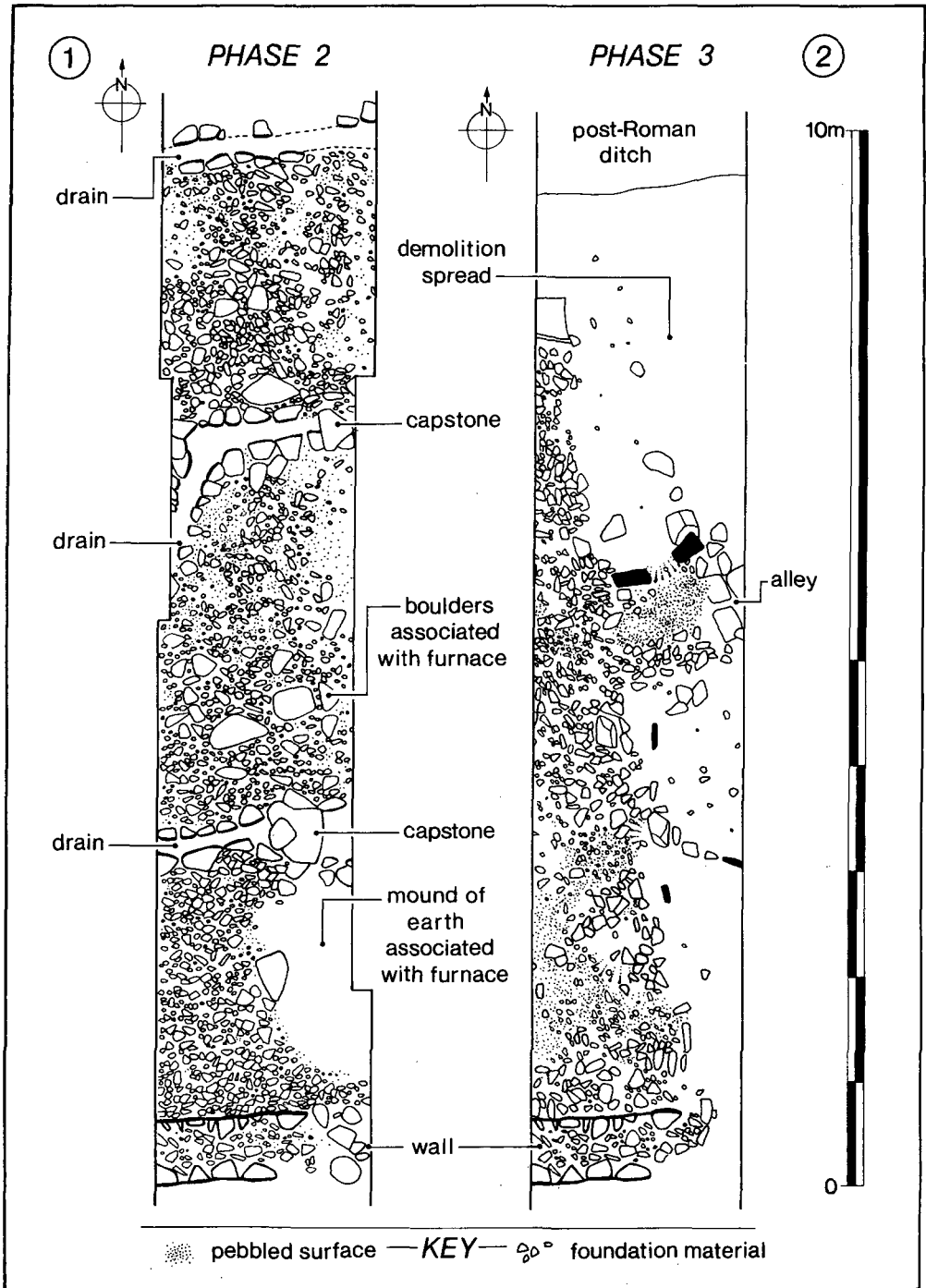

ILLUS 14 South range, phases 2 and 3 plans

zone comprised a loosely kerbed, compact pebble surface set on a foundation of small weathered chunks of millstone grit, which was bounded to the south by the phase 2 wall foundation. The irregular spacing of the posts may, in fact, indicate the presence of two parallel buildings orientated WSW/ENE, as opposed to a single building with its long axis aligned NNW/SSE. A secondary pebble surface no more than 1.1 m wide projected eastwards from the edge of the road, possibly forming a narrow alley between two parallel buildings (illus 14 & 16).

A noticeable attribute of the phase 3 layout was its realignment from the east/west orientation of the preceding building. Excavation was too restricted to shed any light on the precise reasons for this, although constraints from adjacent constructions must be considered the most likely cause. The common alignment between these buildings and the western edge of the expansion provides the intriguing possibility that it was in some way the continuing presence of this structure which was the principal element governing ground plan at this time. It is likely that the road surface articulated with the narrowed Military Way to its north. The exposed ground-plan of these features resembles in form the 'half' barrack-blocks identified in the west *praetentura* at Rough Castle (illus 14 cf. MacIvor, Thomas & Breeze 1980, figs 3–4 and 279). As argued for this site (*ibid.*, 240) the floor levels of the building(s) at Inveravon must have lain above the level of the adjacent surfaces, to prevent water from draining into them.

As a result of this, no *in situ* floor or occupation deposits survived in association with these structures. The floor areas contained substantial spreads of burnt waste material, including quantities of pottery, charcoal, iron nails and burnt daub, some with wattle impressions, which were deposited when the building(s) were demolished and burnt, and the site abandoned. The dearth of Roman brick and tile, particularly from phase 3 demolition deposits, where other structural components of timber buildings were recovered in bulk, suggests that these were not important constructional materials. The roofing may therefore have been of organic materials such as thatch, which would leave little visible archaeological trace (cf. Thomas 1988, 146, for Inveresk). The absence of post-impressions within the post-sockets indicates that they had been uprooted. The combined evidence of the structural remains and demolition waste suggests that the buildings were of very similar character to the most common form identified within the fort on the Antonine Wall at Bearsden (Breeze 1984, 37–8).

Tenacious mottled clay sealed the demolition material in a band 2.3m wide immediately to the south of the narrowed Military Way. Except where sealed beneath the clay, the upper levels of the demolition horizon had subsequently been disturbed by ploughing. The quantity and range of pottery wares and vessel types from this phase, recovered principally from these demolition deposits, were much greater than that from preceding phases, and was similar to the range from contemporary demolition deposits in the northern range. A stone with a pivot hole was found in the demolition material adjacent to the narrowed Military Way (illus 15); it was not *in situ* and its origin is not known.

Southern rampart and exterior

The southern rampart of the small fort, 5.1 m wide, was constructed by the same methods as the Antonine Wall and expansion. Its stone base comprised small pieces of millstone grit set between roughly dressed kerbs, mostly of the same material (illus 17 & 18). The core material was markedly smaller in size than that present in either the Antonine Wall or expansion. Its superstructure survived no more than 0.15 m high, and comprised a silty earth core, with no evidence of turf content, bounded on either side by c 0.5 m wide yellow clay cheeks set above the stone kerbs (illus 18). Once again, there was no evidence for either a buried ground surface or traces of earlier cultivation beneath the rampart.



ILLUS 15 Narrowed southern edge of Military Way, looking north: a pivot stone lies in the foreground

A single alignment of large cobbles incorporated within the stone base was of particular interest. The cobbles had been pressed down firmly into the subsoil and the stone core placed around them (illus 17). They were aligned perpendicular to the rampart, and the southernmost cobble formed part of the outer kerb. This feature is best interpreted as a pre-construction marker to guide construction gangs. It is different in nature to the working division previously identified at Garnhall, where a sharp change in materials used in the Rampart base was taken to indicate the meeting point of two construction gangs (Keppie & Breeze 1981, 238). On the evidence of their uneven surfaces, it is considered unlikely that the cobbles represented post-pads supporting the uprights for a timber structure surmounting the rampart, such as an interval tower.

A road was located immediately adjacent to the external face of the southern rampart (illus 18). It was poorly preserved due to truncation by a post-medieval drainage ditch and erosion of its southern edge, either by ploughing or by river action, but was at least 3.3 m wide. Its northern edge overlapped the upper surfaces of the southern kerb of the southern fort rampart (illus 17). Its surviving parts comprised a compact pebble surface set upon a patchy foundation of small blocks of millstone grit. In the base of the later drainage ditch part of a c 0.65 m wide pit, or possibly the terminus of a gully, was located. As exposed, it bore no direct stratigraphic relationship to the external road, although the similarity of its mottled clay fill to that of the clay cheeks of the adjacent rampart suggests that it is of Roman origin.

In section it was observed that the road did not abut the external kerb of the southern rampart;

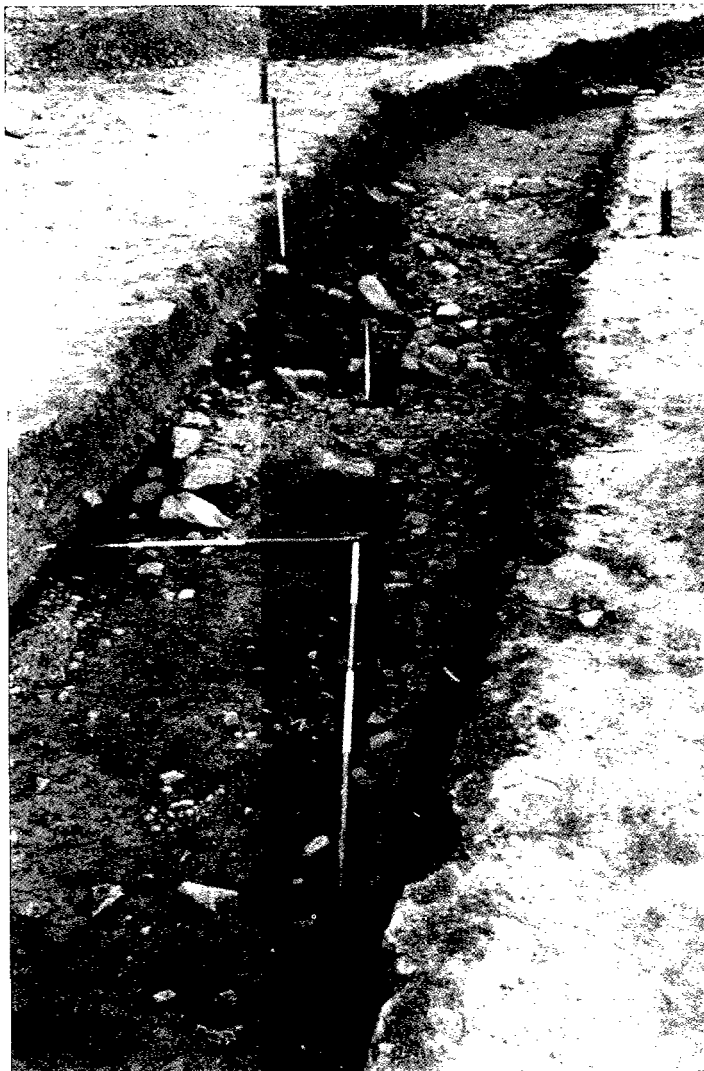

ILLUS 16 South range, phase 3 external surfaces, looking south

a thin finger of fine clay extending from the clay cheek separated the two (illus 18). Its fineness suggests that the finger of clay may be the product of gradual erosion of the cheek. This feature was not continuous across the trench. The implication of this evidence is that the external road did not form part of the primary layout of the small fort. The most likely explanation on the basis of the available evidence is that the external road was built as some form of secondary bypass route to direct traffic around the small fort, when its interior was reorganized and the Military Way narrowed (phase 3). Whilst such bypass roads are known at other forts on the Antonine frontier (eg Rough Castle, Cadder: Hanson & Maxwell (1983a, 84) extend their provision to all forts on the Antonine frontier), none lay quite so close to the fort defences. The uncharacteristic position of this putative



ILLUS 17 Southern rampart of the fort, showing external surface overlapping the south kerb of the rampart, looking north-east

example at Inveravon may simply be due to the proximity of the River Avon, which severely constrained its routing. However, there are too many unknown factors, such as the possible presence and disposition of a defensive ditch system elsewhere around the site, and its relationship to the external road, for this hypothesis to be proposed other than tentatively.

PHASE 4: POST-ROMAN FEATURES

Three discrete types of post-Roman feature were identified: post-medieval ditches; 19th- or 20th-century field drains; and the trenches of previous archaeological excavations. Three near-parallel ditches ran through the trench approximately from east to west (two are visible on illus 12 & 18; the third lay c 2 m south of the Military Way). No traces of adjacent upcast banks were present although, had they once existed, subsequent ploughing would have removed them. The ditches were of the same depth and had similar profiles, suggesting that they were part of a system of land drainage, although possibly also serving as boundary ditches. The fine silty and clayey nature of their fills suggested gradual infilling.

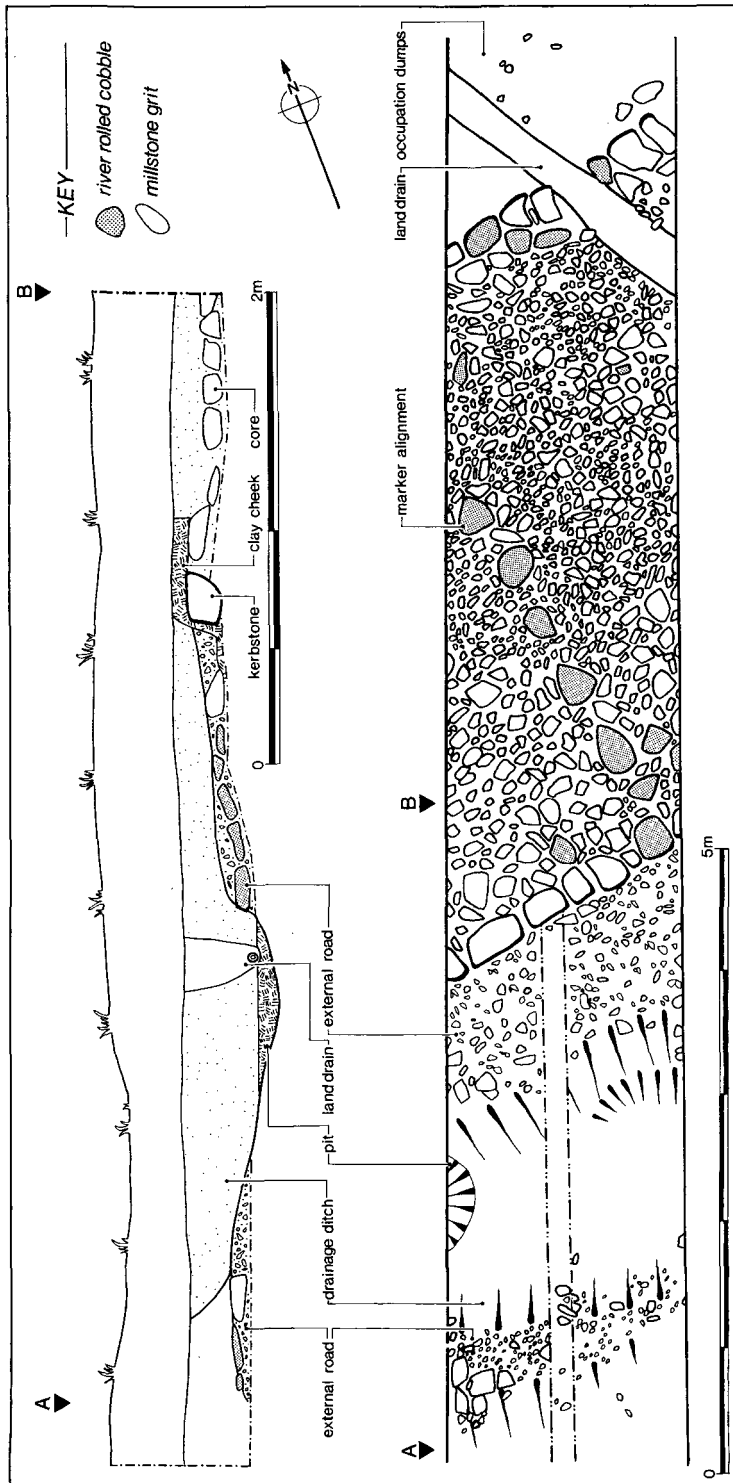

ILLUS 18 Plan and section of southern rampart and external road

They contained pottery sherds from vessels dating between the 14th and 17th centuries AD, but no artefacts of more recent origin. The southernmost example was completely infilled when a 19th- or 20th-century tile drain was inserted along the same line (illus 18). This evidence further supports the proposition that the site had been levelled by cultivation prior to the accounts of 18th-century antiquaries.

More recent land drainage was represented by four drainage pipes and a larger, rubble-filled drain (eg illus 8 & 18), all of 19th- or 20th-century origin. Only two of the tile drains were alike and shared a common alignment, indicating that various attempts to keep the land well drained had been made. Land drainage has evidently presented a problem during the last few centuries.

Sections of three old excavation trenches were recorded, two apparently conjoined and perpendicular to each other (illus 10), cutting through the Military Way and northern range, and the third parallel to one of these and cutting through the southern range. The positions of two of these appear to coincide with trench positions published by Robertson (1969, fig 3, cf illus 1). It is likely that these trenches are associated with Professor Robertson's excavations of 1967 (Robertson 1969). The origin of the trench extending north from the Military Way (shown on illus 10) is not known, and could relate to either Robertson's or Macdonald's excavations in the area.

FINDS SUMMARIES

More detailed reports on the finds are presented on the fiche.

COARSE POTTERY (ILLUS 19–22, NOS 2–78)

Gordon Thomas

The assemblage from Inveravon comprises c 1700 sherds and c 300 fragments. The nature of on-site deposition, which involved substantial rebuilding and the reuse of earlier surfaces, indicates that, in some instances, earlier material may have become incorporated within later deposits. It is therefore necessary to view the integrity of each phase assemblage with some caution.

Owing to the very degraded nature of much of the material it was impossible to make firm identifications of some of the fabric types. In particular, the differences between Black Burnished Ware (BB1 & BB2) and some of the Grey Wares were almost impossible to detect in the absence of microscopic examination. The identification of an increasing range of locally made wares (Breeze 1986) is another factor which should be taken into account but which would, again, require more detailed examination. The discovery of kilns at Bar Hill (Keppie 1985), and possibly also at Croy Hill (Hanson 1979) and Duntocher (Gawthorpe 1980), as well as the presence of wares with a local mineralogical signature at Inveresk (Thomas 1988) and Bearsden (Collins 1986), indicate that more pottery was made in Scotland during the Antonine period than was previously known. Although the occupants of Inveravon may not themselves have been manufacturing pottery, they would certainly have had access to material from neighbouring sites; in particular, the wide range of red/yellow-orange wares from phase 3 could well fall into this category.

Phase 1 and putative furnace

This small group of pottery (approximately 60 sherds) comes from deposits which may have been disturbed and contaminated by later activity. Only the material from the putative furnace comes from a well-sealed deposit. The remainder comes from the disturbed subsoil beneath the phase 2 cobble foundation, in the southern range. It is significant, however, that there is a much higher proportion of BB1 than elsewhere on site, despite bad preservation. This also ties in with the presence of a south Spanish amphora and the stamped samian dish (see below), which suggests a mid-Antonine date for this assemblage. The material associated with the putative furnace has generally been heavily damaged and burnt.

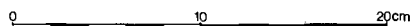
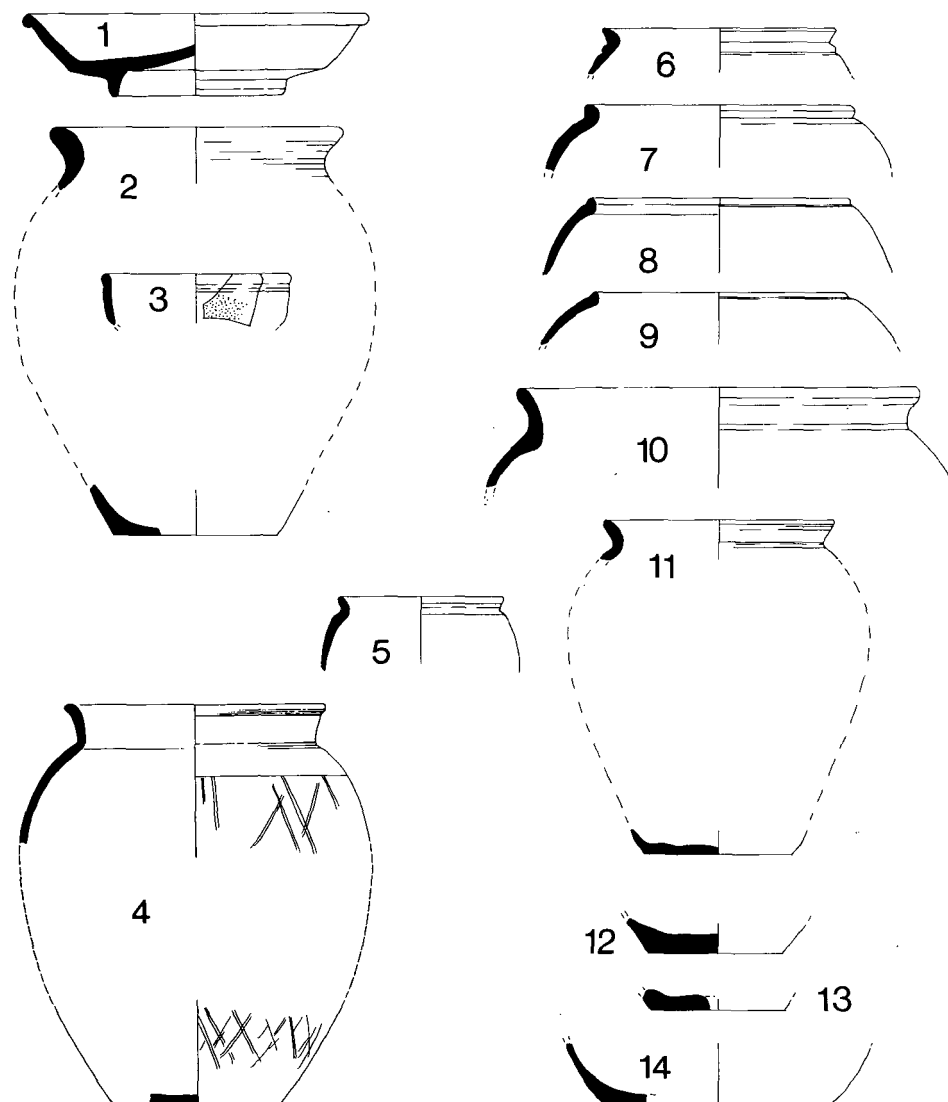

ILLUS 19 Pottery, nos 1-14

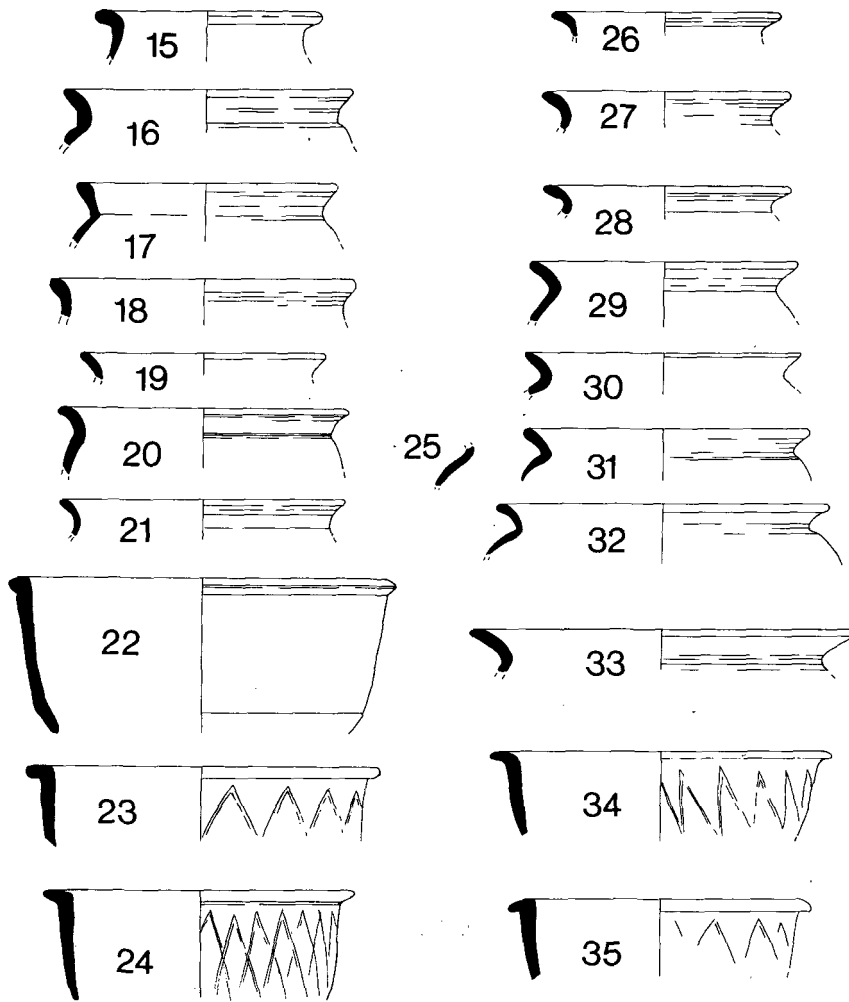

ILLUS 20 Pottery, nos 15-35

Phase 2

Nearly all sherds from deposits associated with the cobble foundation south of the Military Way are of Black Burnished Ware, with both jars and dishes being represented. A hole-mouth jar (no 9) may be a Grey Ware vessel. The homogeneity of the assemblage is significant given its context of recovery. There is a marked absence of the complete range of ordinary domestic vessels, with only those associated with cooking being present. The worn and degraded condition of the material may

also reflect its deposition onto a cobbled surface and associated drains which would, presumably, have seen some considerable use. The phase 2 material from north of the Military Way is of a slightly different nature. BB1 pottery was predominant in lenses of dumped occupation material, and the presence of six joining sherds of a BB2 jar is anomalous.

Apart from three sherds of amphora, fragments of a jar in a smooth yellow/red fabric, and two fragments of possible colour-coated ware, this entire assemblage (approximately 110 sherds) is dominated by the BB and/or Grey Wares. Preservation is poor, suggesting that the material has been exposed to the weather for some time. There is no evidence of burning on any of this material.

Phase 3

The difference between this assemblage and that of the previous phases is marked. The most striking feature is the much wider range of wares and vessel types present, and the much greater quantity of material recovered (approximately 1500 sherds). Black Burnished Ware cooking vessels are still very much in evidence (especially in BB2 forms and fabric), but added to this is a range of bowls, jars, beakers, lids and amphorae in other wares. It is possible that some imitation wares are present. Finer wares such as Castor Ware and rough-cast beakers are also present. Either the supply of pottery or the way in which it was being used and deposited on site had undergone a major change between phases 2 and 3.

The material associated with the southern buildings derives from demolition spreads. The nature of these deposits in particular warns that the possibility of mixing with earlier material must be borne in mind. The northern part of this spread contains pottery linkages over many metres of deposit. This, and the general freshness and size of the sherds, suggests that this material was both deliberately dumped and was not subsequently subjected to constant wear through trampling. This observation should be contrasted, however, with the Black Burnished Ware from the deposits which is in many cases heavily burnt and contains a high proportion of BB1.

The assemblage from the northern range is dominated by over 700 sherds and fragments of amphora from a putative drip trench. These sherds may represent one heavily smashed vessel. A layer sealing this feature also contained an unusually high proportion of amphorae sherds, although in a different fabric.

Conclusions

The assemblage from Inveravon lies comfortably within an Antonine context. The predominance of BB1 and other wares in phases 1 and 2 suggest a mid-Antonine date while the shift in emphasis to BB2 and the increased range of other wares and types, including probably some locally produced wares in phase 3, suggests a late Antonine date for that period of activity on the site. All the wares and vessel types recovered suggest limited domestic activity throughout all phases with the storage, preparation, and consumption of foodstuffs being the primary functions. The almost exclusive nature of the phase 1 and 2 pots, which are restricted largely to cooking pots, suggests a very limited range of domestic activity. The presence of the one 'luxury' vessel from the entire assemblage, a stamped samian dish (see below) in a phase 1 context is, from this point of view, anomalous. The range of pottery is quite limited, with a maximum of only 82 identifiable shapes being noted. Cooking pots, jars, bowls and dishes, mainly in BB Ware, predominate. Amphorae, mortaria and some jars and bowls in other fabrics, possibly local, complete the repertoire. Few fine wares were recovered, the exceptions being the samian dish and a handful of sherds representing some Castor Ware and barbotine or roughcast beakers.

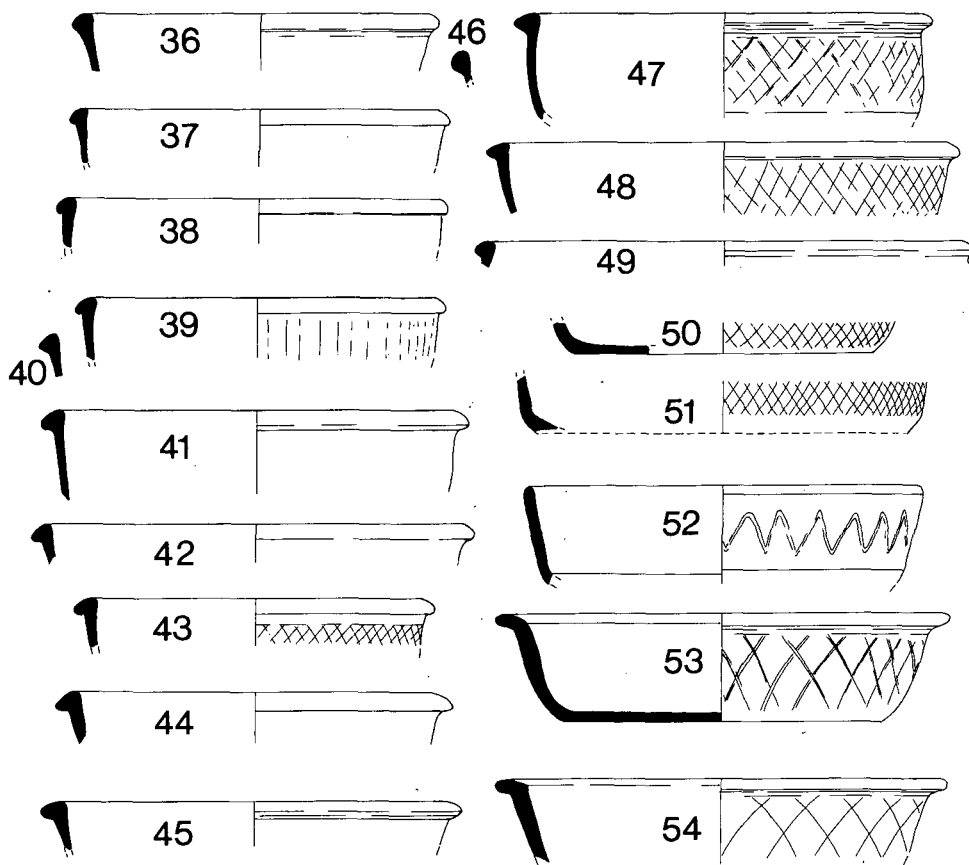

ILLUS 21 Pottery, nos 36–54

The supply of pottery to the site follows well-established patterns observed from other Antonine sites on the Forth/Clyde isthmus. The south and east of England witnessed the growth of several great ceramic industries with markets over the entire province. The production centre of BB1 Wares in Dorset supplied military establishments from the first until the mid-second centuries AD but was later overshadowed by the BB2 industry in the lower Thames valley (Williams 1977). This change may be reflected in the balance of these types between phases 2 and 3 at Inveravon. The majority of the fine wares represented also came from the south and south-east of England (Dickinson, this report; Oswald & Pryce 1920, 181–4, plates XLV–XLVII), while southern Spain produced the olive oil which was the principal content of the Class 25 globular amphora identified from Inveravon (Peacock & Williams 1986, 136–40). This is the

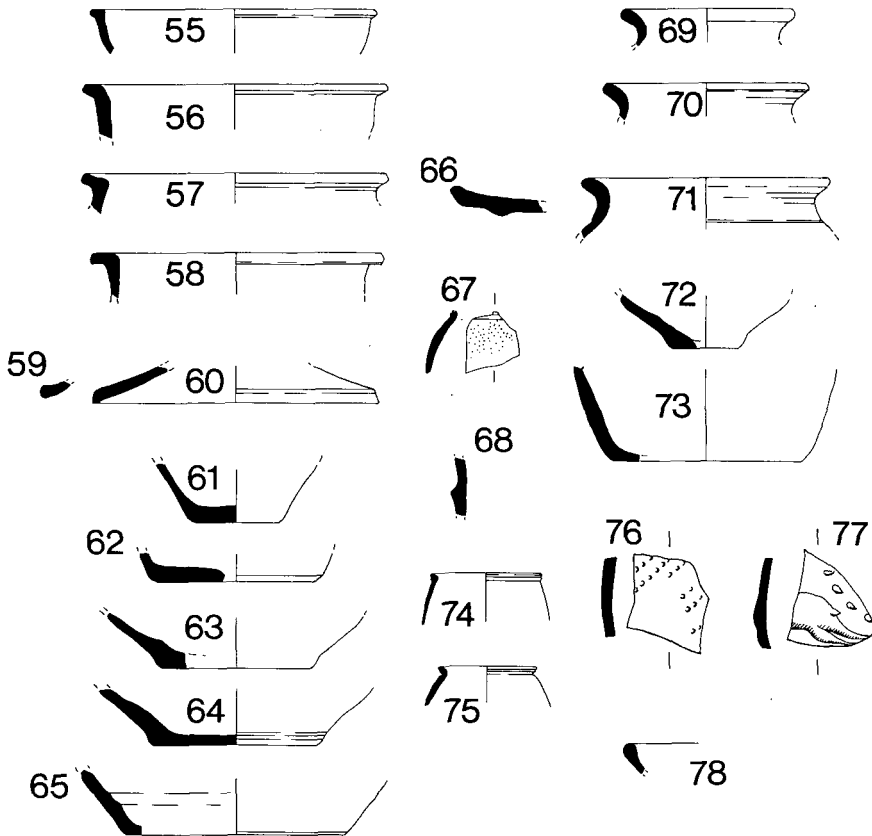

ILLUS 22 Pottery, nos 55-78

most common amphora type found on sites in Britain in this period. Several other amphora fabrics are also present but no identification was possible as diagnostic elements are absent. As far as the other wares and types identified are concerned, it is to be expected that a large proportion of them may have been produced either in the locality of the site or from one of several other sites known to have existed in Scotland. Their virtual absence during the first two phases at Inveravon is noteworthy.

List of illustrated forms

In the list the numbers in brackets detail phase and context number, to allow cross-referencing to the catalogue on microfiche. Comparative material is drawn from Gillam (1968) and from Thomas's work at Inveresk (1988), and is prefixed by 'Gillam' and 'Inv.' respectively.

- 1 Transitional Dr.18/31 – Dr.31 plain Samian dish (1/216)
- 2 Base and everted lip of BB1 jar (1/208), cf Gillam 140
- 3 Rim of small BB bowl (3/106), cf Gillam 308
- 4 BB1 jar with everted rim (3/106), cf Gillam 122, Inv.1.140
- 5 Rim and shoulder of jar with carinated, everted rim and flat base, probably BB2 (3/090), cf Gillam 170, Inv.1.136 but smaller
- 6 Rim and body of BB everted rim jar, possibly in BB2 (2/137), cf. Inv.1.170
- 7 Plain-rimmed BB2 hole-mouth jar (2/163), cf Inv.1.195
- 8 Rim and shoulder from BB jar with plain rim (3/179), cf Inv.1.195
- 9 Inturned hole-mouth jar, possibly in Grey Ware, same vessel as 12 (2/134)
- 10 Rim and shoulder of cooking pot/jar with everted rim (3/090), cf Gillam 117 and 121, Inv.1.159
- 11 Rim and base of BB everted rim jar (3/075), cf Gillam 115–6
- 12 Flat base of jar, same vessel as 9 (2/134)
- 13 Base of BB1 jar (1/216), cf Gillam 116, Inv.1.139
- 14 Base of jar, probably BB2 (3/090)
- 15 Rim of BB flat rimmed jar (3/013), cf Gillam 28
- 16 Everted rim of BB jar (3/045), cf Gillam 141, Inv.1.132–133
- 17 Rim and shoulder of cooking pot/jar with everted rim (3/090), cf Inv.1.273
- 18 Rim fragment of BB everted jar (3/075), cf Gillam 115–6
- 19 Everted rim of BB jar (3/045), cf Gillam 115 but with a more rounded rim
- 20 Plain rimmed BB jar (3/045), cf Gillam 115
- 21 Everted rim of BB jar (3/045), cf Gillam 143, Inv.1.140
- 22 BB1 bowl with rolled rim (2/163), cf Gillam 222
- 23 Flat-rimmed BB1 bowl (3/106), cf Gillam 219/220, Inv.1.86
- 24 Rim and side of bowl with flat rim, possibly BB1 (3/101)
- 25 BB jar with inturned shoulder and everted rim (3/080), cf Gillam 143, Inv.1.130
- 26 Heavily burnt ?BB jar with everted rim (3/012), cf Gillam 145–8
- 27 BB1 jar with everted rim (3/106)
- 28 Everted rim of BB jar (3/012), cf Gillam 139–43
- 29 Rim and shoulder of BB2 jar with everted rim (2/028), cf Gillam 139 and 143, Inv.1.160
- 30 Everted rim of BB jar (3/045), cf Gillam 115 but with a more rounded rim
- 31 BB everted rim jar (3/013), cf Gillam 143–5, Inv.1.134–5
- 32 BB jar with inturned shoulder and everted rim (3/080), cf Gillam 143, Inv.1.130
- 33 BB everted rim jar (2/137)
- 34 Flat-rimmed BB1 bowl (3/106), cf Gillam 219/220
- 35 Flat-rimmed BB1 bowl (3/106), cf Gillam 219/220, Inv.1.86
- 36 BB bowl with rolled rim (3/080), cf Gillam 225
- 37 BB1 bowl with rolled rim (3/101)
- 38 BB2 bowl (3/106), cf Gillam 222
- 39 BB2 bowl (3/106), cf Gillam 222
- 40 BB bowl with rolled rim (3/080), cf Gillam 225
- 41 BB2 bowl (3/106), cf Gillam 222
- 42 Rolled rim from BB2 bowl (2/163), cf Gillam 222
- 43 Rolled rim of BB bowl (3/075), cf Gillam 222
- 44 Rim of BB dish (4/035), cf Gillam 222
- 45 BB dish with rolled rim, possibly BB1 (3/178), cf Gillam 222
- 46 BB bowl with plain moulded rim (4/001)
- 47 BB bowl/dish with plain, moulded rim (3/045), cf Gillam 222 but with less everted sides
- 48 BB2 bowl (3/090), cf Gillam 222
- 49 BB bowl with plain moulded rim (4/001)
- 50 Base of bowl, possibly BB2 (3/106)
- 51 Base of bowl, possibly BB2 (3/106)

- 52 Rim and carination of plain rimmed BB bowl (3/080), cf Gillam 327, which has more vertical walls and lattice decoration, also cf Inv.1.122
- 53 Flat-rimmed BB1 bowl with looped pattern on base (3/106), cf Gillam 308
- 54 Flat-rimmed BB1 bowl (3/106)
- 55 Open bowl with out-turned rim in hard dull orange fabric; exterior surface has horizontal stroke burnishing; fabric compares to other wares thought to be produced in Scotland, in particular Inveresk Ware (3/080), cf Inv.1.230
- 56 Vessel with flat, out-turned rim, with rilled exterior, in fine, smooth light orange-brown fabric (3/106), cf Inv.1.89–90
- 57 Jar with plain, flat base and a ledged rim, in same fabric as 56 (3/106)
- 58 Everted rim of jar in orange brown-buff fabric (3/013)
- 59 Two sherds of the edge of a lid in a smooth, fine orange fabric (3/011)
- 60 Fragment of Grey Ware lid (3/106), cf Gillam 340
- 61 Fragments of base of BB jar (2/162)
- 62 Two joining sherds in smooth yellow/red fabric, from base of flat-bottomed jar (2/162)
- 63 Globular or everted vessel with flat base in fine red/orange fabric (3/012)
- 64 Base of jar in very fine, burnt red fabric (3/045)
- 65 Everted rim of jar in fine, orange fabric (3/175)
- 66 Base of a foot-ringed bowl in soft, grainy buff/brown fabric (3/075)
- 67 Shoulder of jar, in grainy brown fabric (3/106), cf Gillam 168
- 68 Sherd in smooth grey-black fabric with a cream/pink slip, from vessel with raised cordon on shoulder (3/012)
- 69 Everted rim jar in fabric similar to No. 55 (3/101), cf Inv.1.66
- 70 Everted rim jar in smooth, cream/buff fabric (1/173), cf Gillam 115
- 71 Rim of everted grey ware jar (3/156), cf Gillam 119
- 72 Flat base of BB jar (1/173)
- 73 Flat base of Grey Ware jar (3/106), cf Gillam 340
- 74 Rim of cornice rim beaker in dull orange fabric, with black colour coat (3/045), cf Gillam 86/90
- 75 Rough cast cornice rim beaker, possibly Castor Ware (3/106), cf Gillam 86/90
- 76 Sherd in steely blue fabric, with applied raised dot pattern; from Barbotine decorated jar (3/080), cf Gillam 70
- 77 Sherd of colour-coated vessel in fine, white fabric with a black colour coat and applied barbotine decoration, showing the hindquarters of an animal. From a Castor Ware hunt cup (3/080), cf Gillam 84–5
- 78 Rounded plain rim edge of a lid and rim of flagon, in similar fabric to No. 55 (3/026), cf Inv.1.2–1.9

SAMIAN WARE

Gordon Thomas

Most of a plain, stamped transitional Dr.18/31 – Dr.31 dish, with a diameter of 178 mm and a height of 44 mm, was found in the disturbed subsoil sealed beneath the cobble foundations of the phase 2 building south of the Military Way (illus 19, no 1). In addition, an unstratified, undecorated sherd, and a small decorated sherd from a disturbed phase 3 demolition deposit, were recovered. Surface damage to the latter made identification of its motif impossible.

Note on the samian potter's stamp

Brenda Dickinson

The stamp ASIATICI.OF, on the dish of transitional form Dr.18/31 – Dr.31, is from a die used at Lezoux by Asiaticus, and it is the first of his stamps to be recorded from Scotland. There is very little dating from archaeological sites for this potter. The presence of his stamps at South Shields

and Wallsend, combined with his manufacture of forms which did not evolve completely before c AD 160, such as Walters 79, 79R, 80 and Ludowici Tg/Tx, suggests that most of his activity was in the later second century. This particular stamp (from Die 2a) has not yet been noted on any of these forms, and this evidence, and the form of the Inveravon dish, almost certainly means that this die, and one used to stamp Dr.27, are his earliest. Asiaticus may therefore have started work as early as AD 155, although the bulk of his output is of AD 160–190.

MORTARIA (ILLUS 23, NOS 79–82)

Katharine Hartley

Discussion

Only four vessels are represented by the 39 sherds in the Inveravon assemblage. Nos 79–81 all have sherds from a phase 2 context, whereas no 82 derives exclusively from phase 3. The mortaria are from four potteries, in Warwickshire, at Corbridge, in the Verulamium region and from the workshop of Mascellio in Scotland or less probably in the Corbridge/Carlisle area. Together they illustrate the widely differing sources supplying mortaria to Scotland during the Antonine occupations. There is nothing exceptional in their presence except that no 80, from the workshop of Bellicus at Corbridge, is of a later type than one would expect in a context dating to phase 2. The real value of these pieces lies in the extent to which individual pots can be associated with a precise context and phase of the occupation. The many old finds from Scotland provide a good general picture of the mortaria used there but any further progress, for example, a breakdown of the varying sources of supply at differing periods, depends on the adequate publication of precisely provenanced material.

Catalogue (detailed fabric descriptions are on fiche)

- 79 *From deposit on cobble foundation south of Military Way – phase 2:* Two joining fragments from a burnt, well-worn mortarium with an incomplete rim-section. The fabric is typical of the Mancetter-Hartshill potteries in Warwickshire and the form, which would have been stamped, is consistent with production in the Antonine period.
- 80 *A bodysherd from the same deposit as no 79 joins a rimsherd from phase 3 road foundation in southern range; a worn base sherd from the same vessel was recovered from phase 3 demolition deposit in southern range:* The rim, with high bead and stubby downward-pointing flange with faintly marked grooves, is from an unstamped form. The fabric and rim-profile can be attributed to a workshop at Corbridge, whose major stamping potter was Bellicus. This workshop was active within the period AD 155–200, and could have ceased production by AD 190. Bellicus' work does not appear in early Antonine deposits, and there is no evidence of any potter stamping mortaria in Britain after c AD 200; most, if not all, had stopped before that date. The rim-profiles stamped by Bellicus suggest that he was in the last generation of potters to stamp. This mortarium from Inveravon is very unlikely to have been stamped, ie it belongs typologically to a later period than his stamped mortaria. However, this example cannot post-date Bellicus' stamped mortaria, and it may mean that from its inception the workshop produced stamped and unstamped mortaria simultaneously, even if the latter were uncommon. In any case, this example provides the earliest firm dating for this workshop.
- 81 *Three sherds; a rim from same context as no 79 is from the same vessel as two bodysherds from phase 3 demolition contexts on either side of the Military Way:* The rim-profile is typical of some of the unstamped types produced in the potteries of the Verulamium region after c AD 140 (Frere 1972, fig. 121, no. 776). They are typical of the Antonine period, when the importance of these potteries had

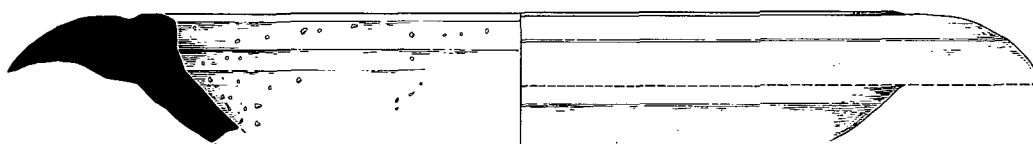

79

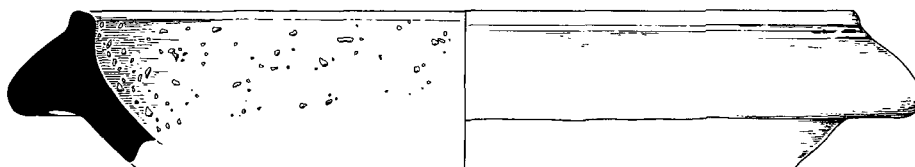

80

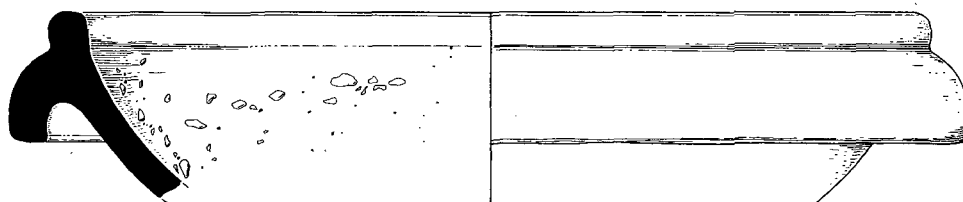

81



82



ILLUS 23 Mortaria, nos 79-82

largely disappeared outside the Verulamium/London area. A few of these products have, however, been found in Antonine contexts in Scotland (eg Cadder).

- 82 *From phase 3 demolition deposits in southern range*: 31 fragments, many joining, together make up more than half of a single worn mortarium; 11 fragments are burnt. There are two stamps, impressed close together on two joining fragments, and another stamp on a fragment, from the other side of the vessel. All three stamps are from the same die, which gives MASC retrograde; this is the most commonly used die of Mascellio and double impressions are recorded. Mortaria stamped with this die are now known from Bar Hill; Bearsden; Birrens; Carlisle (2); Corbridge; Inveravon; Mumrills; Old Kilpatrick; and South Shields. Stamps from other dies probably used by the same potter are known from Bainesse (1–2) and Brompton-on-Swale, both just outside Catterick; Catterick itself (3–4); Chesters Museum; Corbridge; Housesteads; and Piercebridge.

Mascellio's distribution is heavy in the Bainesse/Piercebridge area (6–8 mortaria), and in Scotland (6 mortaria). All six of the mortaria from Scotland are stamped with the same die. In England, up to four mortaria are stamped with two other dies, which are known only in the Bainesse/Catterick area and up to four others with dies only once attested outside that area. Three of his mortaria are from sites on Hadrian's Wall. The fabric used by Mascellio for the Bainesse/Catterick mortaria certainly resembles that of other mortaria made in that area.

The evidence, taken as a whole, suggests that Mascellio worked in the Catterick/Bainesse area before moving north, where he probably worked at Carlisle or Corbridge; there is quite a high probability that he moved to Scotland in the latter part of his life. In view of his markets in Scotland and on Hadrian's Wall, overall activity within the period AD 125–65 can be regarded as certain, whilst any activity in Scotland would have been within the period AD 140–65 (see Bidwell & Speak 1994, for further details).

METAL OBJECTS (ILLUS 24)

Tim Neighbour

Full catalogues of the metal objects are presented on fiche

Copper alloy

The three copper alloy objects of Roman origin included a plain bronze ring from a phase 2/3 occupation dump adjacent to the southern rampart. This artefact disintegrated on touch, and could not be lifted intact. Its degraded condition suggests that bronze objects are under-represented in the finds assemblage. A fragment of the stem of a brass pin with a distinctive rectangular cross-section lay close to the ring, and may be functionally related. A similar robust, tapering brass stem fragment was recovered from a phase 3 demolition spread in the southern range. Large quantities of brass were being used by the Roman period in Europe (Tylecote 1987, 144). The metallurgy of the artefacts was determined by X-ray fluorescence analysis conducted by Peter Davidson of the National Museums of Scotland.

Lead

Nine lead artefacts were recovered, none immediately diagnostic. Irregular, folded strips and sheets, mostly fragmentary, and amorphous scraps, similar in nature to those recorded from Gadebridge Park villa (Neal 1974, 188), are all present (eg illus 24, nos 1–5). All but one of the lead artefacts were found in phase 3 deposits beside and upon the narrowed Military Way. These deposits can be associated with the final demolition and abandonment of the installation.

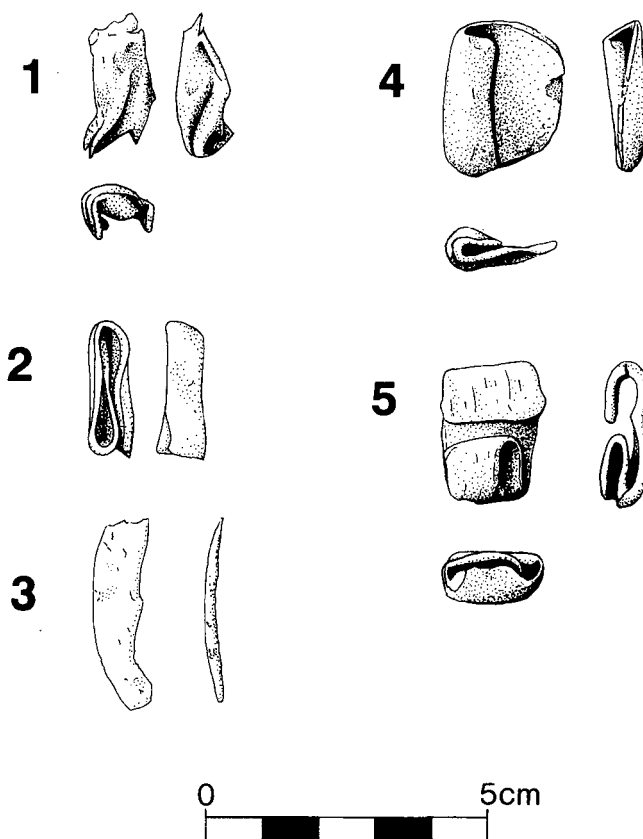

ILLUS 24 Lead artefacts

Iron

Many of the iron artefacts recovered were so corroded and misshapen that little more than a basic identification is possible. The majority of the assemblage was composed of masonry nails and hobnails. Trial cleaning of corrosion from the masonry nails revealed both Manning's broad classification of types I and II to be present (cf Manning 1974). Nails of both types range from 20 mm to 300 mm in length, and were particularly abundant in phase 3 demolition spreads. Perhaps unsurprisingly, hobnails occurred in greatest quantities on deposits directly above pebble surfaces. The outline of the sole of a shoe or boot defined by hobnails lay on the surface of the phase 3 narrowed Military Way. Other iron objects included bolts, a lifting hook, and a knife.

IRON SLAG

Tim Neighbour

The assemblage of iron-working by-products totals 31 pieces. This was separated into visibly similar groups, and a representative example of each group was subjected to X-ray fluorescence analysis by Peter Davidson. All the tested samples proved to be of iron slag resulting from the

smelting of ores. Eighteen pieces had an iron content of nearly 100%; one of them had a 'modern' elemental composition, reflecting its recovery as a stray find. A further five showed an iron content of greater than 80%, and a single piece less than 80%. Eleven pieces proved to be a weathered iron slag. An encrustation on one side of the slag was identified as limonite, a hydrated iron oxide formed by periodic drying and reaction to acidic ground water. The slightly curving profile of a number of these pieces suggests that they may have solidified around the edge of a furnace. A catalogue is provided on fiche.

Approximately half of the assemblage derived from deposits associated with the putative furnace, where they were associated with lumps of coal. The use of coal in the smelting process is attested at other Roman sites (Robertson 1990, 33). Most of the remaining iron slag came from later deposits in the same area, indicating disturbance to deposits associated with the furnace. No ironworking equipment was found in association with these deposits.

OTHER SMALL FINDS

The excavations produced three coins. A copper alloy *As* of Antoninus Pius (identification by N McQ Holmes) was recovered from the occupation deposit on the phase 2 cobble foundation in the southern range. Its surviving detail is not sufficient to allocate the coin to a specific issue. The other two coins are post-Roman in origin, and were recovered as surface finds.

Only a handful of Roman glass shards were recovered. The recognizable forms were parts of two bluish-green, square-sided bottles (identifications by Philip Simpson). These derived from phase 3 demolition deposits. One of the pieces of vessel glass had an arc of a raised circle on its base, which by extrapolation indicates a diameter in the order of 200 mm.

Six fragments of Roman brick were recovered, of which four were securely stratified. No material was present *in situ*. No stratified tile was recovered, and part of an undecorated flue tile recovered as a surface find was the only piece of tile which could be identified as Roman with any confidence. By contrast, burnt daub was present in bulk; approximately 20 pieces showed wattle impressions. Its spatial patterning was very discrete: over 95% by weight derived from phase 3 demolition deposits in the southern range.

The small coarse stone assemblage included a hone (illus 25, no 1) and two whetstones with a rectangular cross-section (illus 25, nos 2 & 3). These objects are associated with the maintenance of metal tools and weapons. An unshaped piece of millstone grit with a series of thin parallel linear grooves had also apparently been used for this purpose. Two small chipped stone discs were recovered from the fill of the innermost gully located on the Berm. Several fragments of lava quern were recovered from a phase 3 demolition deposit in the southern range.

Over 15 joining fragments of a laminated micaceous sandstone slab, 30 mm thick, were recovered from the phase 3 resurfacing on the southern side of the Military Way (illus 26). The refitted object has maximal surviving dimensions of 360 mm by 220 mm, and parts of two edges are preserved. On one side a grid pattern of at least 16 squares by 13 has been incised free-hand, probably with a sharp metal object, resulting in great variation in the size of squares. This design at least appears to have been a board for a game. A similar pattern, incised on a red sandstone flooring slab and measuring at least 15 squares by 11, was recovered at Birrens (Robertson 1975, 100, fig. 26). The other side of the object is inscribed with a semi-regular pattern of seven compass-drawn circles. A small depression in the centre of each circle indicates where one leg of the compass was fixed while the other leg incised the circle. Two attempts appear to have been made at engraving one of the circles - two central compass points and concentric arcs can be seen (bottom right on illus 26). No parallels have been identified for this design; it need not necessarily have been for a game.

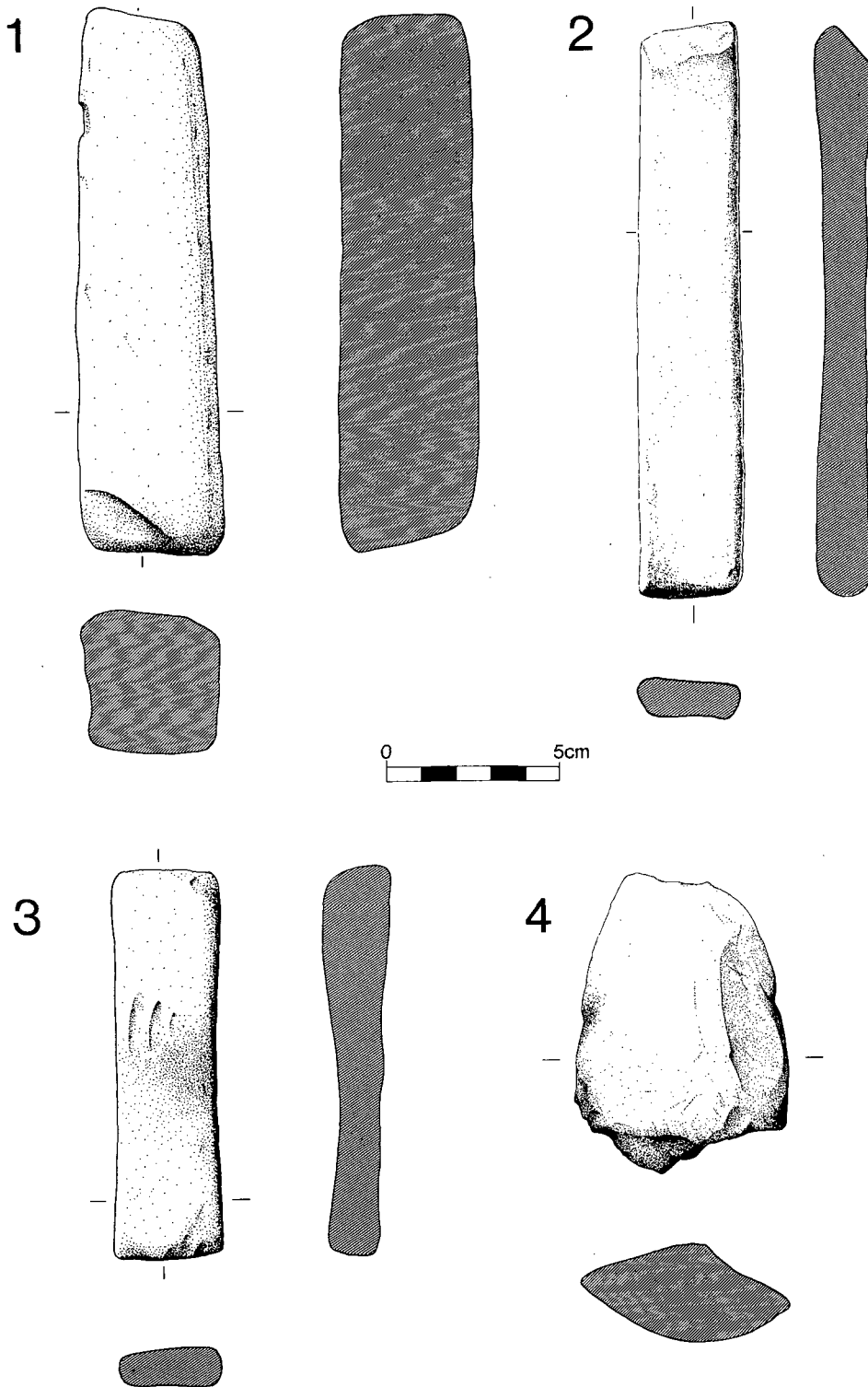

ILLUS 25 Stone objects: hone, whetstones, and stone axe

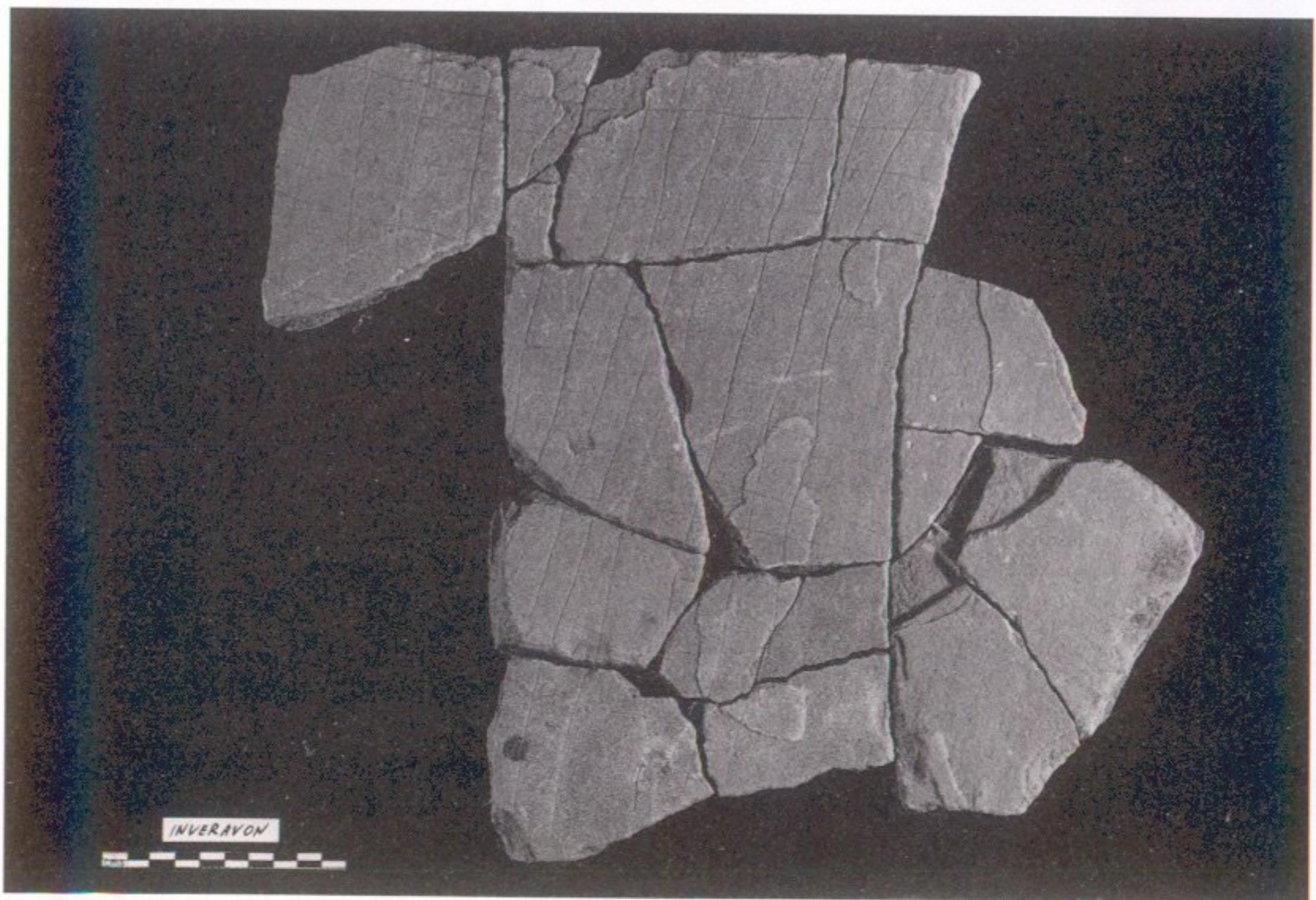
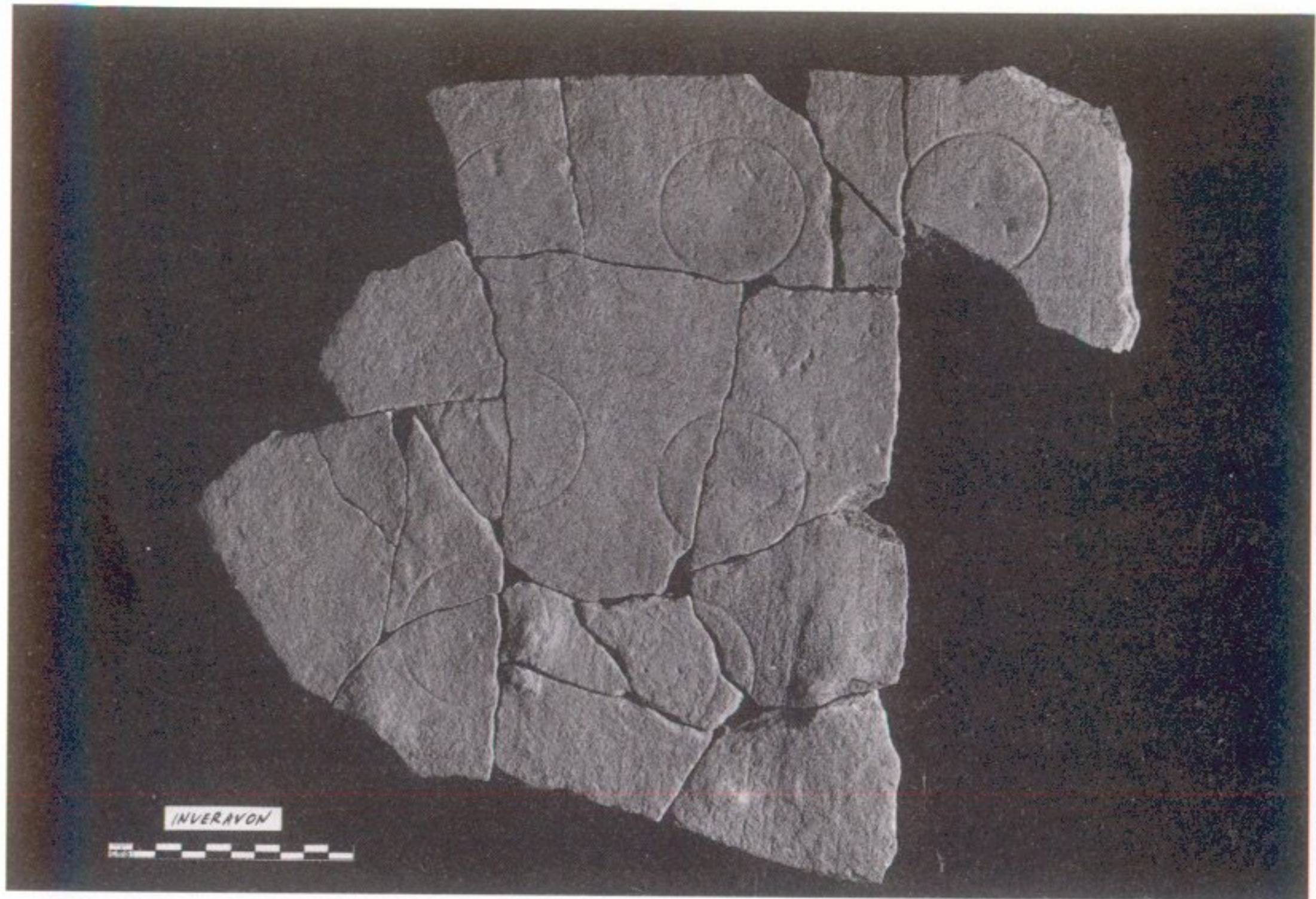

ILLUS 26 Gaming board, showing circular (upper) and grid (lower) patterns

The faunal remains from Inveravon constitute a small collection of 45 bone fragments. The material is all burned and has a white calcined appearance. These pieces are too fragmented to identify, with one exception: this piece, a fragment of the diaphysis of a left radius, is probably that of a sheep, but the absence of the epiphysial ends makes identification uncertain. Unburnt bone was not preserved on the site.

Full catalogues of these materials, including the coarse stone by Ann Clarke and the animal bone by Nicola Murray, are presented on fiche.

PREHISTORIC FINDS

Chipped stone

Bill Finlayson

Twelve pieces of chipped flint were recovered during excavation, of which only two were derived from stratified Roman levels. The remainder were found either as surface finds or were from post-Roman features. The assemblage included nine regular and irregular inner flakes, most probably of prehistoric origin. Whilst the Mesolithic-Neolithic shell midden adjacent to the excavation provides a focus of activity which may explain the presence of the artefacts, the assemblage may reflect no more than the ubiquitous background scatter of such material. In addition, two undiagnostic 'strike-a-lights' and a gunflint were recovered.

Ground stone axehead (illus 25, no 4)

Alison Sheridan

The upper portion of a ground stone axehead which had been broken and discarded in prehistory was recovered as a surface find beside the trench. The raw material is a baked siltstone cobble, probably selected from local beach or drift deposits. Although the overall shape of the axehead cannot be reconstructed precisely, it appears that the cobble had been only slightly modified to make it usable. The shape and position of the break line – a bending/compressive fracture around or just above half-way up the body – suggests that the axehead broke as a result of a mis-hit during use. No attempt had been made to re-shape or re-use the butt before discard. A Neolithic date is quite likely, although a Bronze Age date cannot be ruled out; unfortunately the axehead has no diagnostic features which would aid its closer dating.

POST-ROMAN POTTERY

The assemblage of post-Roman pottery from the site comprised 90 sherds, of which 49 were surface or topsoil finds, 28 were from post-Roman features, and the rest were contaminants introduced by ploughing into the disturbed upper levels of Roman stratigraphy. The assemblage dates from the 13th/14th century to the early 20th century. Over 50 sherds are of 19th/20th-century origin, and up to 20 are of the 15th century or earlier. These pre-modern vessels are predominantly jugs with green glaze coating, of which one 15th-century example may have been manufactured at Stenhouse. A cooking pot, possibly of the 13th-century, was also represented (pottery identifications by George Haggarty).

ENVIRONMENTAL EVIDENCE

Geraint Coles & Helen Crossley

A preliminary assessment was made of the nature and quality of the environmental evidence from Inveravon. This assessment involved sediment analysis, wet sieving for organic residues and trial palynological analysis.

The majority of examined sediments appeared to be reworked alluvial silts and clays with a gritty content possibly derived from trampling and industrial activity. None of the examined samples showed any clear evidence of subsistence activity. Charcoal was recovered from all occupation and demolition deposits submitted for analysis, although none was identifiable to species. No plant macrofossils of either weed or crop plants were recorded. No macroscopic organic remains were recovered from samples of drain fills associated with the phase 2 building to the south of the Military Way.

Palynological analysis was initiated on four samples. However, there are considerable problems associated with the interpretation of soil pollen (cf. Dimpleby 1985; Tipping *et al* 1994), and the results of the analysis therefore must be treated with caution. The samples, of 10 ml volume, were processed by standard techniques (cf. Moore & Webb 1978) and were mounted in silicone oil. Exploratory counts of around 100 determinable grains were made to assess the likely value of further work.

The four palynological samples examined in this study were from: phase 1 earthen core of the expansion; clay layer, possibly a ground surface, sealed beneath Upcast Mound; fill of phase 2 drain in southern range; and phase 3 deposit lying on the Military Way.

All four samples contained a low concentration of pollen and spores, and a corresponding very low species diversity. The pollen was poorly preserved, showing signs of surface pitting, corrosion and degradation. Indeterminate grains were common in all samples. It should be noted that the determinable taxa recorded were generally restricted to species or genera thought to have a relatively high resistance to biological degradation, such as Pine (*Pinus*) and Ferns (*Filicales* undifferentiated) (see Havinga 1984, and references therein). Given this observation, and the poor preservation state of the assemblages generally, it is suggested that the pollen and spores recorded here are residual, and result from the weathering of formally more extensive assemblages; in consequence, no reliance can be placed on their palaeoecological interpretation.

Nevertheless, the assemblages show some variation which may reflect changing environmental conditions at the time of their original deposition prior to weathering. The samples produced the following results:

TABLE 1
Results of Palynological Analysis*

Taxa	Sample 1	2	3	4	Taxa	Sample 1	2	3	4
	% TLP					% TLP			
<i>Trees</i>					Rosaceae	0.5			
Pinus	12	21.5		5	Chrysosplenium			0.5	0.5
Betula	5	2.5	0.5	0.5	Umbelliferae			0.5	0.5
Coryloid	5			1.0	Oxyria type	3.5			
Salix	2	1			Rumex acetosella		3.5	2.5	2.0
Alnus	11.5		0.5	0.5	Rumex acetosa				0.5
Quercus	24			0.5	Plantago lanceolata				0.5
<i>Heathers</i>					Campanula type	1			
Ericaceae		0.5	10	9	Compositae (liguliflorae)	0.5	0.5	15	12
<i>Grasses/sedges</i>					Bidens type	0.5		5	2
Poaceae	11	11	19	15	Carduus			0.5	1
Cyperaceae	16.5	53	37.5	39.5	Cirsium		0.5	0.5	0.5
<i>Herbs</i>					Serratula type			2	
Ranunculus	6	4.5	5.5	3.5	<i>Ferns and mosses</i>				
Sinapis type	1			0.5	Pteridium	10		1	2.5
Caryophyllaceae		1		0.5	Fiticales				
Chenopodiaceae		0.5	0.5	5	Undifferentiated	17.5	5	18.5	9
					Sphagnum	1	15	12	5.5

* Sum = percentage Total Land Pollen (TLP) excluding ferns and mosses.

Sample 1: Given that this material may be redeposited topsoil it is possible that the pollen and spore assemblage was reworked along with the soil matrix and thus reflects conditions considerably prior to the construction of the fort. Records of Alder (*Alnus*) and Oak (*Quercus*) suggest stands of Alder in the damp valley floor, with Oak on the higher parts of the local topography.

Sample 2: If the field interpretation of this context as an old ground surface is correct, this layer predated the construction of the Roman fort. The assemblage is dominated by Pine, Sedges (*Cyperaceae*) and grasses, with a number of wet-ground Cryptogams (*Sphagnum*) suggesting a damp open area with Pine woodland on the surrounding higher ground.

Sample 3: The near absence of tree taxa suggests that the local area had been cleared of woodland, although the increase of heathers suggests heathland expansion. The presence of Sedges, Liguliflorae and Cryptogams suggest damp open, rank, grassland as the most likely ground cover around the fort at this time.

Sample 4: Relatively similar to Sample 1, although the presence of fewer Cryptogams and more grasses and open ground herbs suggests human activity in creating a slightly drier and more open local environment (presumably on the site itself).

DISCUSSION

The limited extent of the excavation inevitably presents significant problems in the interpretation of the results. Many issues traditionally assessed in excavation reports regarding Roman military sites, such as the nature and size of the garrison, cannot be evaluated on the basis of this work. A complex series of remains were identified but, as at other sites where only sample excavation has occurred, these most probably do not provide a full account of the structural history of the site at Inveravon. Had the trench been positioned a few metres to either side of that excavated, the presence of an expansion would not have been detected. Less informative dating evidence might have been recovered, with the result that different conclusions would have been drawn regarding the date of construction of the fort. Our understanding of the site would of course benefit from any future excavation.

The presence of an expansion adjacent to the Rampart and subsequently a small fort, as well as the dating evidence, combine to indicate that Inveravon cannot be readily compared to other forts on the Antonine frontier. The results of the excavation suggest that the history of the construction and garrisoning of the Antonine frontier is actually more complex than some recent accounts would suggest. Points discussed in the following sections are those based upon the more solid results of the excavation.

A PRIMARY EXPANSION

The apparent presence of an expansion at Inveravon brings the total so far identified to seven. Some of its structural characteristics, particularly its ground plan and size (see above), are at variance from those known of the other six examples (Steer 1957). This variation need not be surprising, particularly given the limited amount of excavation which has been carried out upon this class of monument. There is in fact no reason to presume that such simple constructions necessarily were all of identical size and shape (as is the case with forts and fortlets identified on the frontier), or possibly even performed the same function.

The evidence for the relationship of the Inveravon example to the Rampart is somewhat equivocal. Some details suggest the expansion to be a secondary addition – the earthen cores of two structures were not bonded, but were separated by the unbroken southern cheek of the Rampart, and the stone base of the expansion abutted that of the Rampart. However, the relationship between the clay cheeks of the two structures at their excavated western junction was less clear. Although turf-lines present within the clay cheek of the expansion slightly overlapped the south kerb of the Rampart (eg *illus 6*), and were initially thought to indicate that the two structures were bonded (cf Armit & Dunwell 1992, 79; Dunwell 1992), this may have resulted from distortion as a result of the settling of the structures after their construction, and the field evidence cannot definitely support the argument either way. On balance, the excavated data tend to support the conclusion, although with some reservations, that the Rampart was constructed before the expansion: clarification of this matter should form a research priority for any future work at the site.

The evidence for this relationship from other sites is equally confusing. Sections excavated through the Croy Hill expansions demonstrated this pair to be secondary additions to the Rampart (Glasgow Archaeological Society 1899, 77–9 & 84–5; Robertson 1969, 37–9). Interestingly, at Croy Hill West, in a section of the Antonine Wall where turf construction is almost ubiquitous, a clay cheek appears to have separated the two structures (Glasgow Archaeological Society 1899, photograph on p 78). At Bonnyside East, however, Steer recorded that the two turf superstructures were bonded (1957, 164), although it must be admitted that his published section does not show this incontrovertibly (*ibid*, fig 3): a majority of the illustrated turf lines terminated directly above the kerb of the Antonine Wall, as did a deposit of stones and pebbles incorporated within the turf core of the Antonine Wall, and of the two turf-lines which did appear continuous one showed a pronounced kink directly above the kerb. There remains a suspicion that here too the expansion was added to the Rampart, and that the evidence Steer observed was at least partly the result of subsequent settling.

If the expansion at Inveravon was an addition to the Rampart, then this evidence is of no use in estimating the length of time between the two periods of construction. At Croy Hill West this interval was thought to have been probably very short (Glasgow Archaeological Society 1899, 79), although the basis for this conclusion is not clear. The addition of the Inveravon expansion could either have been planned from the outset, with the archaeologically detectable stratigraphic relationships reflecting the actions of successive construction gangs, or have been the result of a decision taken subsequently.

The excavation at Inveravon provided little direct information relevant to the function of the expansion. It was almost certainly built to provide a line of sight over the top of the Antonine Wall. The post-hole present within the clay cheek provides some tentative evidence for the presence of a timber superstructure. Patches of occupation material containing pottery and an irregular arrangement of stake-holes adjacent to the structure provide some evidence of activity, and possibly suggest that the feature was manned. There was no indication that this expansion, or indeed any of the other identified examples, lay within a ditched enclosure; the excavated structure cannot therefore be compared to the minor enclosures of obscure function to either side of Wilderness Plantation fortlet (Hanson & Maxwell 1983b).

Perhaps most significant was the absence of spreads of burnt material, such as identified at Bonnyside East (Steer 1957, 167). Expansions have generally been accepted, in Maxwell's words, 'faute de mieux' (1989a, 148), as forming part of a communications network, with a specific function as a beacon stance preferred on the basis of the recovery of this burnt material. Steer further proposed (1957, 168) that, as these structures did not appear to be located at regular

intervals along the frontier, they were not intended for lateral communication along the frontier, but rather for long-distance communications to north or south.

Irrespective of the lack of burnt material, topographic considerations militate against a communications platform, whether beacon stance or watchtower, at Inveravon. The site has good views only northwards across the Firth of Forth, to an area of Fife and Clackmannan where permanent Roman military occupation has yet to be attested. For the site to function within a lateral communications network a second station would have been required on higher ground to either side of the River Avon, which would have rendered the expansion largely redundant in the first place. It is conceivable that contact with ships in the Firth of Forth was intended. Pollen analysis provides tentative evidence that the land beside the River Avon was less wooded than the slopes and brow of the ridge to either side of it, and it may have been that this spot provided the clearest line of sight to the Firth of Forth. As the identified expansions do not seem to form part of a continuous, regular system on the basis of the available evidence, the location of this example on low-lying ground can hardly be envisaged to have been dictated by the necessities of spacing, and its position was presumably specifically planned (cf Peel Gap, on Hadrian's Wall, where a turret-sized tower was constructed in a topographical position unsuitable for any form of surveillance, and was explained as the result of rigid spacing between turrets; Crow 1991, 53).

By way of conclusion, the use of the term 'expansion' to describe the partially exposed structure at Inveravon implies a less rigid definition than that adopted by Steer (1957, 166), who saw them as having a 'uniformity of design' and a 'common purpose'. Such structures may have served different functions in different places, in response to specific tactical needs requiring a line of sight across the wall-top. There is still a long way to go before a proper understanding of these enigmatic structures can be achieved.

THE ADDITION OF A FORT

The excavation has considerably enhanced the information regarding the nature of the Roman site at Inveravon compared to that previously recorded by Robertson (1969), but even so only an incomplete understanding is yet possible. Identification of a rampart defining the southern side of the occupation at Inveravon clearly indicates that a military site is present. The remains are sufficiently extensive to be discounted as those of a fortlet, and the balance of evidence suggests the site was a small fort. However, only a hazy definition of the nature and extent of the site can be established: no precise east/west dimension can be given for it, and it is far from clear where within it the present trench was located. The failure hitherto of aerial reconnaissance and geophysical survey to identify any coherent trace of the site removes an important yardstick by which the excavations could be calibrated. The discussion regarding the nature of the site is therefore necessarily kept to a minimum.

Extent

The remains identified by this excavation and Robertson's previous trenching (1969) are together too extensive to be those of a standard frontier fortlet. On the Antonine Wall such sites form a distinct group in size terms. For the identified examples on the Antonine frontier, the range of north-south dimension within ramparts varies from 15.5 m at Watling Lodge to 22 m at Croy Hill (Hanson & Maxwell 1983a, 95; table 5.2), which is markedly smaller than the distance of 34.5 m recorded at Inveravon. Furthermore Robertson's excavations (1969) suggest an east/west measurement of at least 35 m, which is almost double the nearly standard 18-18.5 m recorded at

fortlet sites. When viewed in terms of internal area the disparity between Inveravon and known fortlets is even more evident: assuming a regular form, the minimum estimate of 0.12 ha for Inveravon is three times that of Croy Hill, the largest fortlet. The identification of an east/west axial internal alignment at Inveravon in at least one phase of occupation, contrary to the north/south axis of fortlets, and the presence of stone-built structures, are further significant differences.

If the remains are not those of a fortlet, then, from the structures identified and terminology applied hitherto on the Antonine frontier, this must be the site of a fort, albeit a very small one. At first glance, the known dimensions of the site are almost ludicrously small for consideration as a fort, even when compared to Duntocher, which had internal dimensions, excluding the annexe, of c 41.5 m by c 50 m and an area of 0.2 ha (Robertson 1957). For Inveravon to have an area approaching even this size it would require an east/west dimension of c 60 m, supposing a very elongate form, with its length greater than its width by a factor of almost 1.75. Such proportions would be wholly unusual on the Antonine Wall, but are by no means impossible, especially given the severe constraints which the proximity of the River Avon must have placed upon the layout of the site. However, most of the forts on the Antonine frontier appear to have been furnished with a defended annexe, thus overall substantially increasing their overall size and creating a more elongate form. There is meantime no clear indication from aerial photography, or otherwise, where precisely an annexe may be located.

Unfortunately, at Inveravon, no trace of a defensive ditch system has been identified, by which the extent of the fort could be judged. Cropmark features, including the Antonine Ditch, are readily identifiable on aerial coverage (illus 2). The presence of an undetected ditch system can be countenanced only if it is wholly enclosed within and obscured by the darker band on the aerial coverage (illus 2, D), where the clarity of the Antonine Ditch cropmark is reduced, and if the pipe trench had passed through a gap within the ditch system, or perhaps where it had been eroded. Perhaps the proximity of the river restricted space and/or removed the defensive necessity for enclosing ditches, at least on the west and south sides of the small fort. However, this is not paralleled at other Roman forts in riverside locations.

Character and date of the occupation

Due to the narrowness of the trench, it was possible to gain no more than a restricted view into the nature of the occupation within the ramparts. However, the results, although limited, did reveal some intriguing evidence. The interior was divided into two ranges by a central road running east/west, to either side of which two successive structural phases were identified. Little can be said of the structures which were present, or of the nature or size of the garrison. In the northern range a rough stone surface was replaced by a road probably flanking a building during the life of the fort. In the southern range a composite building, possibly with a timber frontage beside the Military Way with an open courtyard to its rear, was replaced by timber-framed buildings on a different alignment (illus 10). There is no means of identifying the function or size of the buildings from the available evidence, although it is probably significant that the pottery from the earlier phase was restricted to vessels associated with cooking. The samian dish of Asiaticus sealed beneath these structures, and the mortarium of Bellicus from deposits associated with the earlier structure in the southern range, indicate that this activity must date to AD 155–160 at the earliest. The demolition and burning of the site on its abandonment mirrors the evidence from many other military sites on the frontier.

It is now evident that the stone walls located by Robertson (1969) relate to structures occupying the northern range, probably in phase 3. At least one structure, 11.5 m wide externally

and of unknown length, although possibly with two inter-connecting chambers, lay 4.5 m south of the Antonine Wall and was bordered by a road surface to both north and south, the latter extensive and with two phases. The southern wall of this structure lay c 15 m to the south of the Antonine Wall, and appears to have been built over the Military Way. A fragment of stone foundation, c 1.5 m long, abutting the Antonine Wall, identified in a trench over 20 m to the west of the others, cannot now realistically be identified as part of the same structure on the basis of the excavated sample (*contra* Robertson 1990, 46; where the presence of a single, multi-chambered building up to 27 m wide and over 30 m long is proposed).

Whilst a secure *terminus post quem* can be attached to the principal occupation phases within the fort on the basis of ceramic evidence, an assessment of the dates of initial construction and final abandonment of the fort is based upon considerably more circumstantial evidence. The two phases of structures in the southern range were preceded by a putative iron-smelting furnace; it is likely that this feature was used within the ramparts of the small fort, but there were no stratigraphic links by which this could be confirmed. It is considered that this furnace reflects a primary phase of activity within the small fort. The samian dish does not date the construction of this furnace nor that of the southern rampart. The dish lay in a disturbed subsoil deposit partly cut by the furnace, but it is not unlikely that this deposit continued to be disturbed after the construction of the furnace and during the phase 2 construction within the fort. Assuming the furnace to be an intramural feature, the small fort therefore may have been constructed before the date of AD 155–160 suggested by the samian dish. Within the excavated transect, there was little evidence for any features contemporary with the furnace which might have indicated widespread primary intramural occupation. To summarize, the fort need not have been constructed as late as AD 155–60, but it could have been.

An important implication of these uncertainties is that it would be extremely unwise to attempt to relate the construction of the fort to the traditional model of an Antonine II reoccupation of Scotland in the late AD 150s. A reorganization of manning and a reduction in the garrison on the frontier has been generally ascribed to AD 158, following a short-lived abandonment (eg Hanson & Maxwell 1983a; Breeze 1975, 73–4; Breeze 1982, 121). However, Hodgson's (1995) critical analysis of the dating evidence for Antonine Scotland has persuasively discounted many of the arguments for two distinct Antonine occupations, and suggests that the validity of the terms Antonine I and Antonine II should be questioned.

The date of abandonment of Inveravon can only be a matter of speculation as there is no reliable means of estimating the length of occupation. Nevertheless, this matter is of importance, as the date of the abandonment of the Antonine frontier as a whole is a controversial subject. A date of c AD 165 is currently favoured for the end of permanent occupation (eg Hanson & Maxwell 1983a, 143). Although an acceptance of this date would indicate that a late flurry of building activity had occurred at Inveravon, it is nevertheless possible to interpret the excavated remains within this framework. However, this abandonment date does not meet with universal acceptance, and it is worth assessing briefly the Inveravon evidence in the context of other hypotheses proposing earlier and later dates of abandonment. Hodgson followed up his arguments, rejecting two separate Antonine occupations, by suggesting that a gradual withdrawal of Roman forces from Scotland may have started as early as AD 155–158, and envisaged '... a drawn out and complex process of transfer ...' from the Antonine Wall to Hadrian's Wall, with some sites still occupied on the Antonine frontier while the refurbishment of Hadrian's Wall was being completed (1995, 38–9). The Inveravon evidence does not sit happily within this model, as we would be required to interpret much of the excavated sequence as withdrawal-phase activity or post-withdrawal patrol occupation, although it does not completely rule out Hodgson's model.

Conversely, claims have also been made for the occupation of the Antonine frontier as late as the AD 180s and 190s (eg Mann 1988; see Hanson & Breeze 1991, 63 for a summary); a scatter of stray finds, dating to the AD 160s and AD 170s, is often used to support these arguments. Whilst there is nothing in the Inveravon finds assemblage to suggest occupation here post-dating the AD 160s, it is important to note that the dates attributed by the relevant specialists to the samian dish and to the Bellicus mortarium sherd lie at the very beginning of their potential date range. Brenda Dickinson notes that the bulk of Asiaticus's work dates to AD 160–190, whereas Kay Hartley notes that the mortarium provides the earliest firm date for Bellicus' workshop. Later dates may be possible for these items. It is important to avoid a circular argument, such as could be created by dating the artefacts within the framework currently favoured for the occupation of the Antonine Wall, whilst at the same time using the proposed date of the artefacts to support a date for the abandonment of the Antonine frontier in the AD 160s. The upshot of the considerations above is that the excavated evidence is insufficient to propose a date for the abandonment of the fort with any confidence; various interpretative models are available, and the Inveravon data could be fitted into any of these, albeit in some cases with a tighter squeeze than others.

A suggested annexe

It has recently been suggested that the excavated remains are those of an annexe (Bailey 1994, 304), presumably implying that an associated fort lay on the higher ground at the eastern end of the field. This argument appears to be weakened by the dearth of archaeological evidence for Roman occupation in the higher part of the field. A series of exploratory trenches excavated by Robertson, revealed no trace of a fort within approximately 35 m of the eastern edge of the field, although the stone base of the Rampart was partly preserved (1969, 40; unpublished plans, approximate trench locations reproduced on ill. 1), suggesting that conditions for the preservation of features within a fort were present. Unless all trace of the site has been eroded, it would appear that the Roman site did not extend this far east. The stone spread, from which a sherd of mortarium was collected, discovered by Macdonald 'towards the top of the field' (1925, 271) may hint at Roman remains, but their precise location is unknown. Furthermore, had a fort been present on the higher ground away from the river, the presence of a defensive ditch system surrounding its north, east and west sides might have been more warranted, yet none is visible on the available aerial photographic coverage. Quite why the fort was not situated on higher ground is unclear – perhaps the desire to position it as close as possible to the river crossing was the overriding factor (as argued for Strageath: Frere & Wilkes 1989, 5).

Although an iron-smelting furnace is perhaps more likely to have been located within a defended annexe, where industrial activities are believed to have taken place, this was not invariably the case. At Rough Castle, for example, the position of a possible bowl furnace was identified by a cluster of fragments of furnace-lining on the inside of the north rampart of the fort (MacIvor, Thomas & Breeze 1980, 283). Unfortunately, a combination of limited, in some cases poorly recorded, fieldwork and poor preservation of remains in frontier fort annexes has meant that little coherent information on the range of buildings present has been garnered against which to compare the fragments exposed at Inveravon.

CONCLUSIONS

That a secondary small fort lay on the Antonine frontier at Inveravon is now beyond question. Its exact date of construction is not clear, but the buildings excavated during current work would appear – on the basis of Hanson & Maxwell's (1983a) proposed chronology of Antonine

occupation – to date to the later years of the permanent garrison of the frontier, and the suspicion is that the fort was not built until around this time. If correct, Macdonald's hypothesis that the misalignment of the frontier works on either side of the River Avon was due to the planned presence of a fort (1934, 194) would require revision.

The absence of any clear evidence for an early Antonine permanent military garrison on the frontier at Inveravon is of interest. Kinneil fortlet remains the only installation known on the Antonine frontier between the forts of Carriden and Mumrills for which an early Antonine occupation is attested (Keppie & Walker 1981, 151). The suspected fort in the Kinneil area has yet to be discovered, and its absence must be contemplated (cf Breeze 1980, 52). An early Antonine garrison in the Inveravon area would therefore appear to have been necessary for the maintenance of a regular system of surveillance. Robertson's suggestion (1974, 100–1) that a second site lies undiscovered in the vicinity may yet prove to be correct. It may be that this site is a fortlet, still unlocated, which was subsequently replaced by the small fort on the east bank of the river.

ACKNOWLEDGEMENTS

The project was wholly funded by Shell Chemicals UK Ltd. Environmental co-ordination for the company was undertaken by Dr Alan Ryder, assisted by Mr David Maynard. The project was managed by Dr Ian Armit, now of Historic Scotland, assisted by Dr Bill Finlayson. Thanks are due to all the specialist contributors; to Mr Peter Davidson and Mr R Reekie, both of the Geology Department of the National Museums of Scotland, for undertaking X-ray fluorescence analysis of the metal finds, and petrological identification of the stone axe respectively; to Mr George Haggarty, Dr Philip Simpson and Mr Nicholas Holmes who kindly identified the post-Roman pottery, glass and the coins respectively, and to Mr Alex Quinn for conserving the coins. We are also grateful to Professor Emerita Anne Robertson, Mr Geoff Bailey of Falkirk Museum, Dr Lawrence Keppie of the Hunterian Museum, and Dr Richard Hingley and Dr David Breeze of Historic Scotland for their comments on an earlier draft of this report. We would like to thank all the field staff, ably supervised by Alan Braby and Jamie Hamilton, for their tireless contributions. The illustrations for this report were prepared by Kirsty Cameron (1, 4, 8, 12–14, 18); Kevin Hicks (3, 5, 10, 11, 23); and Martin Wilson (19–22, 24–5) whose drawings for the interim report (Armit & Dunwell 1992) were used in the production of many of the other illustrations produced here. While thanks are due to all the above-mentioned, responsibility for the final form of this paper rests with the authors and with the Centre for Field Archaeology.

ARCHIVE

A fieldwork report, including details of the stratification (Armit & Dunwell 1992), as well as details of the desk-based stages of work relevant to the site (Ralston & Armit 1990, 124–5), and the site records have been deposited in the National Monuments Record of Scotland (NMRS). Copies of the interim accounts have also been lodged with Central Regional Council's Sites and Monuments Record.

REFERENCES

- Armit, I & Dunwell A J 1992 *Excavations on the Antonine Wall and Fort at Inveravon (Parcel 007), near Grangemouth, Central Region, March–June 1991* (3 vols). NWEPA Archaeological Studies (Scotland) Phase 2, Series 2 Report No. 10. Unpublished report, Centre for Field Archaeology, Univ Edinburgh, archived in NMRS.

- Austin, R G 1934 'Roman board games I', *Greece & Rome*, 4 (10) (1934), 24–34.
- Austin, R G 1935 'Roman board games II', *Greece & Rome*, 4 (11) (1935), 76–82.
- Bailey, G B 1992 'Another look at the eastern end of the Antonine Wall', *Glasgow Archaeol Soc Bulletin*, 28 (1992), 6–8.
- Bailey, G B 1994 'The provision of fort-annexes on the Antonine Wall', *Proc Soc Antiq Scot*, 124 (1994), 299–314.
- Bidwell, P T & Speak, S C 1994 *Excavations at South Shields Roman Fort, Volume 1* (Soc Antiq Newcastle upon Tyne monogr 4). Newcastle.
- Breeze, D J 1975 'The abandonment of the Antonine Wall: its date and implications', *Scott Archaeol Forum*, 7 (1975), 67–80.
- Breeze, D J 1979 *Roman Scotland: Some Recent Excavations*. Edinburgh.
- Breeze, D J 1980 'Roman Scotland during the reign of Antoninus Pius', in Hanson, W S & Keppie, L J F (eds) *Roman Frontier Studies 1979*, Oxford, 45–61 (= *BAR Int Ser* 71(i)).
- Breeze, D J 1982 *The Northern Frontiers of Roman Britain*. London.
- Breeze, D J 1984 'The Roman fort on the Antonine Wall at Bearsden', in Breeze, D J (ed) *Studies in Scottish Antiquity Presented to Stewart Cruden*, Edinburgh, 32–68.
- Breeze, D J 1986 'The manufacture of pottery in Roman Scotland', *Proc Soc Antiq Scot*, 116 (1986), 185–9.
- Buchanan, M, Christison, D & Anderson, J 1905 'Report on the Society's excavation of Rough Castle on the Antonine vallum', *Proc Soc Antiq Scot*, 39 (1905), 442–99.
- Burnham, B C, Keppie, L J F, & Esmonde Cleary, A S, Hassall, M W C & Tomlin, R S O (eds) 1993 'Roman Britain in 1992', *Britannia*, 24 (1993), 269–322.
- Collins, G H 1986 'Petrological examination of Roman pottery from Bearsden', in Breeze 1986, 188–9.
- Crow, J G 1991 'A review of current research on the turrets and curtain of Hadrian's Wall', *Britannia*, 22 (1991), 51–63.
- Dimbleby, G W 1985 *The Palynology of Archaeological Sites*. London.
- Dunwell, A J 1992 'Recent work on the Antonine Wall at Inveravon, Grangemouth, Central Region, 1991', *Glasgow Archaeol Soc Bulletin*, 29 (1992), 3–6.
- Frere, S S 1972 *Verulamium Excavations, Vol 1*. London (= Res Rep Soc Antiq Lond, 28).
- Frere, S S & Wilkes, J J 1989 *Strageath: Excavations within the Roman Fort, 1973–86*. London (= *Britannia Monogr Ser*, 9).
- Gawthorpe, S 1980 'Roman pottery from the Antonine Fort and Fortlet, Golden Hill, Duntocher', *Clydebank Hist J*, 1 (1980), 15–18.
- Geophysical Surveys (Bradford) 1990 *Report on Geophysical Survey, Site 7*. Unpublished report, archived in NMRS.
- Gillam, J P 1968 *Types of Roman Coarse Pottery Vessels in Northern Britain*, 2nd edn. Newcastle upon Tyne.
- Gillam, J P 1976 'Possible changes in plan in the course of the construction of the Antonine Wall', *Scott Archaeol Forum*, 7 (1975), 51–6.
- Glasgow Archaeological Society 1899 *The Antonine Wall Report*. Glasgow.
- Gordon, A 1726 *Itinerarium Septentrionale*. London.
- Hanson, W S 1979 'Croy Hill', in Breeze 1979, 19–20.
- Hanson, W S 1982 'Roman military timber buildings: construction and reconstruction', in McGrail, S (ed), *Woodworking Techniques Before AD 1500*, Oxford, 169–86 (= *BAR Int Ser*, 129).
- Hanson, W S & Breeze, D J 1991 'The future of Roman Scotland', in Hanson, W S & Slater, E A (ed), *Scottish Archaeology: New Perceptions*, Aberdeen, 57–80.
- Hanson, W S & Maxwell, G S 1983a *Rome's North West Frontier: the Antonine Wall*. Edinburgh.
- Hanson, W S & Maxwell, G S 1983b 'Minor enclosures on the Antonine Wall at Wilderness Plantation', *Britannia*, 14 (1983), 227–43.
- Havinga, A J 1984 'A 20-year experimental investigation into the differential corrosion susceptibility of pollen and spores in various soil types', *Pollen et Spores*, 26 (3–4) (1984), 541–58.
- Hodgson, N 1995 'Were there two Antonine occupations of Scotland?' *Britannia*, 26 (1995), 29–49.
- Jackson, D A & Tylecote, R F 1988 'Two new Romano-British iron-working sites in Northamptonshire – a new type of furnace', *Britannia*, 19 (1988), 275–99.

- Keppie, L J F 1974 'The building of the Antonine Wall: archaeological and epigraphic evidence', *Proc Soc Antiq Scot*, 105 (1972–4), 151–65.
- Keppie, L J F 1985 'Excavations at the Roman fort on Bar Hill, 1978–82', *Glasgow Archaeol J*, 12 (1985), 49–81.
- Keppie, L J F & Breeze, D J 1981 'Some excavations on the line of the Antonine Wall, 1957–80', *Proc Soc Antiq Scot*, 111 (1981), 229–47.
- Keppie, L J F & Walker, J J 1981 'Fortlets on the Antonine Wall at Seabegs Wood, Kinneil and Cleddans', *Britannia*, 12 (1981), 143–62.
- Macdonald, G 1925 'Further discoveries on the line of the Antonine Wall', *Proc Soc Antiq Scot*, 59 (1924–5), 270–95.
- Macdonald, G 1934 *The Roman Wall in Scotland*, 2nd edn. Oxford.
- MacIvor, I, Thomas, M C & Breeze, D J 1980 'Excavations on the Antonine Wall fort of Rough Castle, Stirlingshire, 1957–61', *Proc Soc Antiq Scot*, 110 (1978–80), 230–85.
- MacKie, E W 1972 'Radiocarbon dates for two Mesolithic shell heaps and a Neolithic axe factory in Scotland', *Proc Prehist Soc*, 38 (1972), 412–15.
- Mann, J C 1988 'The history of the Antonine Wall: a reappraisal', *Proc Soc Antiq Scot*, 118 (1988), 131–7.
- Manning, W H 1974 'Objects of Iron', in Neal 1974, 157–87.
- Maxfield, V A 1979 'Camelon 'south camp' excavation 1975–9', in Breeze 1979, 28–32.
- Maxwell, G S 1989a *The Romans in Scotland*. Edinburgh.
- Maxwell, G S 1989b 'Aerial reconnaissance on the Antonine Wall', in Kennedy, D (ed) *Into the Sun: Essays in Air Photography in Archaeology in Honour of Derrick Riley*, Sheffield, 173–88.
- Moore, P D & Webb, J A 1978 *An Illustrated Guide to Pollen Analysis*. London.
- Neal, D S 1974 *The Excavation of the Roman Villa in Gadebridge Park, Hemel Hempstead, 1963–8*. (= *Res Rep Soc Antiq Lond*, 31). London.
- Olausson, D 1983 *Lithic Technological Analysis of the Thin-Butted Axe*. Lund.
- Oswald, F & Pryce, T D 1920 *An Introduction to the Study of Terra Sigillata Treated from a Chronological Standpoint*. London.
- Peacock, D P S & Williams, D F 1986 *Amphorae and the Roman Economy: An Introductory Guide*. London.
- Ralston I B M & Armit I 1990 *North-Western Ethylene Pipeline (Grangemouth-English/Scottish Border), Archaeological Studies (Scotland), Phase 1, Final Report*. Unpublished report, Centre for Field Archaeology, Univ Edinburgh, archived in NMRS.
- RCAHMS 1929 *Tenth Report with Inventory of Monuments and Constructions in the Counties of Midlothian and West Lothian*. Edinburgh.
- Robertson, A S 1957 *An Antonine Fort: Golden Hill, Duntocher*. Edinburgh.
- Robertson, A S 1969 'Recent work on the Antonine Wall', *Glasgow Archaeol J*, 1 (1969), 37–42.
- Robertson, A S 1974 'River crossings on the Antonine Wall', in Birley, E, Dobson, B & Jarrett, M (eds) *Roman Frontier Studies 1969*, Cardiff, 94–101.
- Robertson, A S 1975 *Birrens (Blatobulgium)*. Edinburgh.
- Robertson, A S 1990 *The Antonine Wall: A Handbook to the Surviving Remains*, 4th edn, rev L J F Keppie. Glasgow.
- Roy, W 1793 *The Military Antiquities of the Romans in Britain*. London.
- Sibbald, R 1707 *Historical Inquiries*. Edinburgh.
- Sibbald, R 1710 *The History of the Sheriffdoms of Linlithgow and Stirling (Ancient and Modern)*. Edinburgh.
- Steer, K A 1957 'The nature and purpose of the expansions on the Antonine Wall', *Proc Soc Antiq Scot*, 90 (1957), 161–9.
- Stevenson, R B K 1946 'A shell-heap at Polmonthill, Falkirk', *Proc Soc Antiq Scot*, 80 (1945–6), 135–9.
- Stuart, R 1845 *Caledonia Romana: a Descriptive Account of the Roman Antiquities of Scotland*, 1st edn. Edinburgh.
- Thomas, G D 1988 'Excavations at the Roman civil settlement at Inveresk, 1976–77', *Proc Soc Antiq Scot*, 118 (1988), 139–76.
- Tipping, R, Carter S & Johnston, D 1994 'Soil pollen and soil micromorphological analyses of old ground surfaces on Biggar Common, Borders Region, Scotland', *J Arch Sci*, 21 (1994), 387–401.

- Turner, R C 1979 'The identification of the game', in Potter, T W, *Romans in North-West England. Excavations at the Roman Forts of Ravenglass, Watercrook and Bowness on Solway, Kendal*, 76–79 (= *Cumberland & Westmorland Antiq Archaeol Soc Res Series*, 1).
- Tylecote, R F 1987 *The Early History of Metallurgy in Europe*. London.
- Webster, J 1975 'Objects of lead', in Cunliffe, B, *Excavations at Porchester Castle Vol 1: Roman*, (= *Res Rep Soc Antiq Lond*, 32).
- Williams, D F 1977 'Black burnished ware from Mumrills: a reappraisal of sources of heavy mineral analysis', in Dore, J & Greene, K (ed), *Roman Pottery Studies in Britain and Beyond*, Oxford, 177–87 (= *BAR Supp Ser*, 30).

This paper is published with the aid of a grant from Shell Chemicals UK Ltd