

## The excavation of a Bronze Age cemetery at Seafield West, near Inverness, Highland

Michael Cressey\* & Alison Sheridan†

with contributions by Ciara Clarke, Mike Church, Thea Gabra-Sanders, Jacqueline McKinley, Peter Northover & Graeme Warren

### ABSTRACT

*Excavations in 1996 in advance of a major commercial development at Seafield West revealed a Bronze Age cemetery. Inside a ring-ditch were two adjacent graves with wooden coffins, one a boat-shaped hollowed tree-trunk, the other plank-built. Both had probably contained crouched inhumation burials. Grave goods in the former included a bronze dagger of 'Butterwick' type whose scabbard of wood and cattle hide produced a date of  $3385 \pm 45$  BP (1870–1520 cal BC at  $2\sigma$ ), slightly later than expected; those in the latter included an 'Irish Bowl' Food Vessel, believed to date to c 2000 BC. Both items indicate links with Ireland. Also inside the ring-ditch were: a short stone cist; a pit containing cremated human remains accompanied by three burnt barbed-and-tanged arrowheads and a mandible fragment, probably of a dog or fox; and three pits, at least one of which might have been an inhumation grave. Outside, and to the east, was a second short stone cist with a Beaker; to the west, a cluster of truncated pit graves containing cremated human bone and pyre debris, and in one case the remains of an urn and accessory vessel. One of these pit graves, dated to  $3360 \pm 50$  BP (1750–1510 cal BC at  $2\sigma$ ), contained the remains of an adult with cut marks on the skull. The cemetery is around 700m from – and on the same gravel ridge as – the multi-phase site at Stoneyfield, Raigmore, whose later phases featured a cist cemetery and a pit with a Cordoned Urn cremation burial. Some residual lithic evidence for Mesolithic activity in the area was also recovered.*

In memory of Ken Browell

### INTRODUCTION

Michael Cressey

In 1996 the Centre for Field Archaeology, then of the University of Edinburgh, was invited to investigate two cropmark sites in advance of the construction of a business and enterprise park at Seafield West, Inverness (NGR: NH 6946 2452). One of these sites was situated on

a sand and gravel ridge at 26m OD, close to the A96 Inverness to Nairn trunk road (illus 1). North of this ridge the land falls steeply towards the shore of the Moray Firth, while to the south the landscape is now reclaimed flood plain with underlying alluvial sand and clay.

The archaeological site was identified in the National Monuments Record of Scotland

\* CFA Archaeology Ltd, Suite 2, Archibald Hope House, Eskmills Business Park, Musselburgh EH21 7PQ

† Archaeology Dept, National Museums of Scotland, Chambers St, Edinburgh EH1 1JF

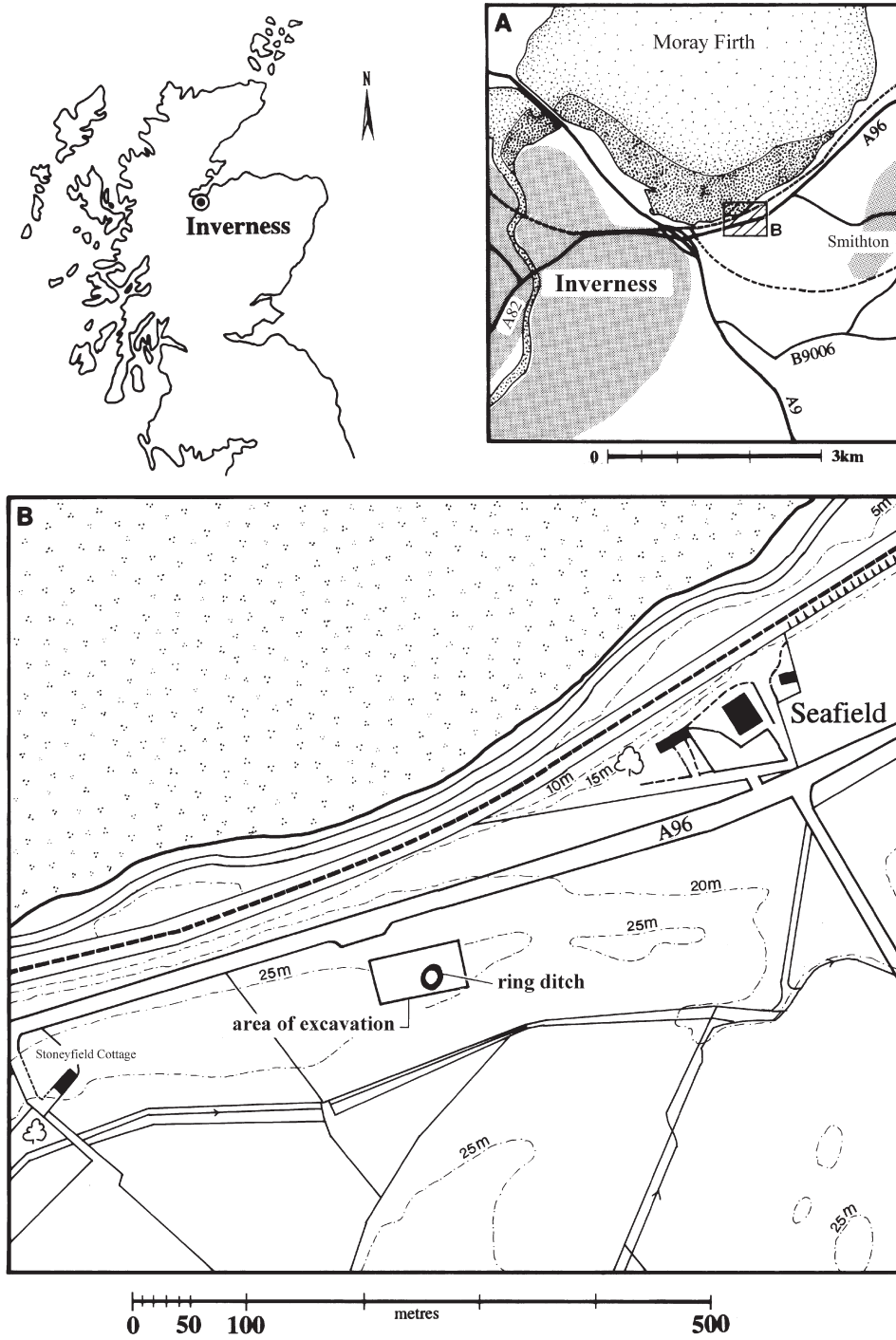

ILLUS 1 Location map (Based on the Ordnance Survey map © Crown copyright)

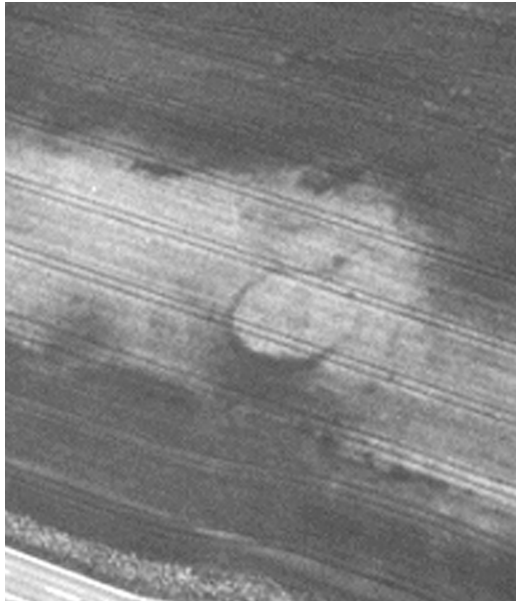

ILLUS 2 Aerial photograph of the Seafield West area (RCAHMS © Crown copyright)

(NH 64 NE 40) as a ring-ditch, pit alignment and a possible enclosure (illus 2). In addition, a collection of flint artefacts had previously been recovered by local archaeologist Mr

Allen Ross during fieldwalking along the ridge, around Area 1, and in fields in the former floodplain (Area 2). These artefacts included a large quantity of diverse worked flints, some of which have been identified as distinctively Mesolithic. Two episodes of geophysical survey, in 1993 (Banks 1993) and prior to trial excavation, revealed respectively: two possible fire-spots; a possible rectilinear structure; and a possible enclosure; and in the second, two areas of burning west of the ring-ditch. Systematic fieldwalking confirmed that there was no appreciable pattern to the distribution of flints and suggested that the artefact distribution was purely random.

Seven trial trenches were opened to investigate features identified on the aerial photographs and the geophysical survey. The principal archaeological features recorded at this stage were: nine pits containing deposits of charcoal; the ring-ditch with an apparent cairn at its centre; and a short cist to the east of the site. Trenches opened to locate the features identified during the 1993 geophysical survey and a possible pit alignment in the area revealed nothing. Full details of this work are

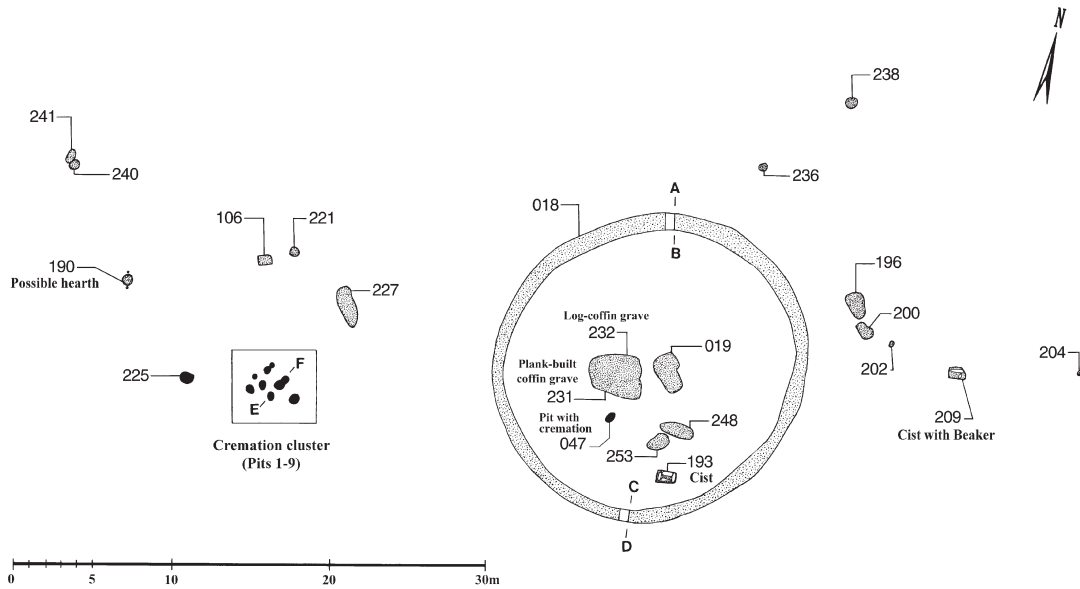

ILLUS 3 Plan of the excavated features

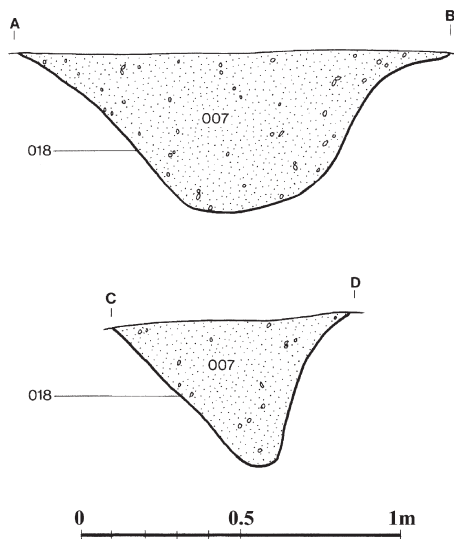

ILLUS 4 Sections through the ring ditch (A–B, C–D on illus 3)

in the project archive (Cressey 1996). Larger scale excavation was undertaken between July and August 1996. A single trench measuring 60m by 40m was opened with topsoil carefully removed by mechanical excavator to expose the features identified during the evaluation. Excavation then concentrated on the ring-ditch, the nine outlying cremation pits and two short cists that had been identified. Other features investigated included a hearth of unknown age and a number of other small pits of uncertain function (illus 3).

### THE RING-DITCH

The ditch encloses a sub-circular area measuring 18.3m east/west by 17.5m north/south. No entrance was identified. Nine sections were excavated across the ditch to determine fill characteristics and to identify any evidence of re-cutting. The ditch had a variable profile (illus 4) and its fill, varying in depth between 0.6 and 0.9m, showed no signs of re-cutting. It consisted of a mixed orange-brown sand containing fine to medium sized pebbles, which contrasted with the natural sand which was laminated with bands of gravel. No archaeological artefacts or palaeoenvironmental evidence were recovered from the ditch fills that were examined,

although 1.2g of scattered cremated bone (SF 2), representing the remains of a subadult or adult, were found.

### INTERNAL FEATURES

The features identified within the ring-ditch (illus 3) comprise: the remains of a cairn sealing adjacent pits containing a plank-built wooden coffin and a boat-shaped log-coffin; a short cist; a pit containing a cremation burial; and three other pits (contexts 248, 253 and 019), of which at least one (248) could have been an inhumation grave.

### THE CAIRN

During the archaeological evaluation, a feature just to the west of the centre of the area enclosed by the ring-ditch was identified as the possible remains of a cairn. This comprised a collection of plough-scarred boulders, measuring on average 0.3m by 0.2m. They formed a heart-shaped arrangement, a single layer thick, covering an area of 3sq m, and standing no higher than 0.25m. It may be that the heart shape – no doubt modified by plough damage – reflected the construction of two distinct but conjoining cairns over the two graves beneath them. An iron object (SF4), found lodged between two of these boulders, was considered to be a recent implement tip. Further cleaning around the boulders produced six flint artefacts (SF 5–10) including a microburin, all representing residual Mesolithic material. A small amount of cremated human bone (0.4g, SF 3), representing the remains of a subadult or adult, was also found among the cairn material, but whether it relates to the same individual as the bone fragments found in the ring-ditch cannot be determined. It is assumed that these finds had become lodged between the stones as a result of ploughing; but if they had been deliberately deposited, parallels for such a practice can be cited (eg at Balfarg Riding School, cairn, B, burials 3 & 4; Barclay & Russell-White 1993, 136).

### PLANK-BUILT COFFIN GRAVE

After removing approximately 0.05m of the sediment underneath the cairn, an irregular D-shaped cut was observed (illus 5), measuring c 2.8m by 1.6m at its greatest extent. Further excavation to a depth of 0.15m revealed a roughly rectangular organic stain (206). This appeared to outline the

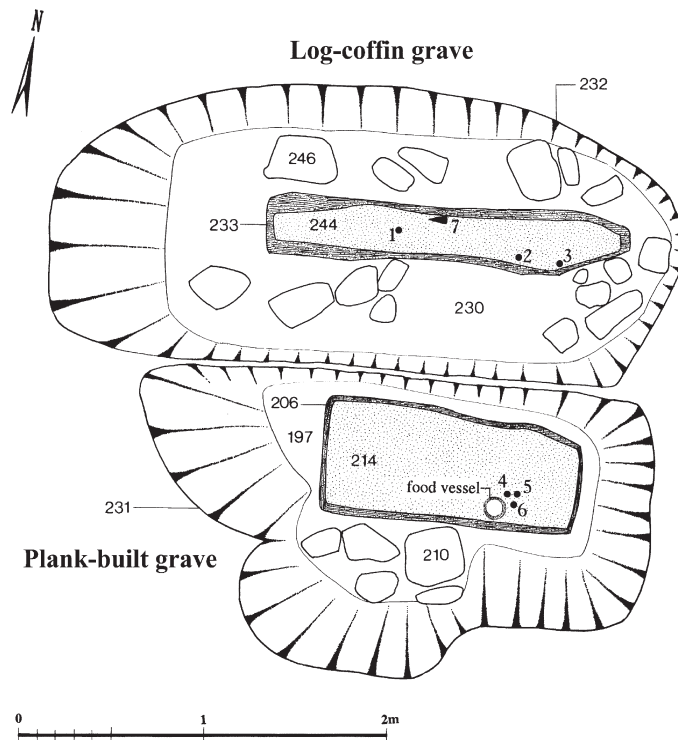

ILLUS 5 Plan of the graves containing wooden coffins. The three-figure numbers are context numbers. Key to others: 1 human femur (SF 21); 2 human tooth (SF 22); 3 flint flake (SF 20, now lost); 4 flint flake (SF 13, now lost); 5 flint scraper (SF 15); 6 flint knife (SF 14); 7 dagger (SF 18). Not shown: residual Mesolithic flints and flint flake SF 16

position of a wholly-decayed plank-built wooden coffin, aligned east/west and measuring 1.4m by 0.6m. The sides were 1–2cm thick and its base was elliptical on plan. Its fill (214), 0.14m deep, consisted of light orange-brown sand with small pebbles. No body stain, unburnt or cremated bone or charcoal was recovered from within it, although phosphate analysis (see below) strongly suggested the former presence of human remains or some other phosphate-rich organic material. If, as seems likely, a body had been present, it must have been placed in a crouched position, to judge from the coffin's dimensions (and by analogy with comparable graves elsewhere, eg Bowthorpe, Norfolk: Lawson 1986). A complete Irish Bowl Food Vessel (SF 17, illus 10.2) was found standing upright, towards the south-east corner of the coffin. A sample of the blackish encrustation on the pot's interior produced an anomalously late date of

2625 ± 45 BP (900–750 cal BC at 89.7% of 2σ, AA-29063); as will be argued below, the expected date for this kind of pottery is c 2200–1950 BC. Beside the pot were four flint artefacts (SF 13–16, illus 15, SF 13 lost shortly after excavation); a large edge-retouched knife (SF 14); a large convex scraper (SF 15); and a tertiary flake (SF16) which could have been struck from the same parent cobble as the scraper. Also present, within the general fill of this grave, were a patinated flake and core of flint (SF 11–12), representing residual Mesolithic material.

LOG-COFFIN GRAVE

The cut for this feature (232) formed a very irregular D shape (illus 5 & 6), and lay immediately to the NNW of that for the plank-built coffin grave – so close, indeed, that it was impossible to determine whether both had been dug at the same time,



ILLUS 6 The log-coffin during excavation

or whether one pre-dated the other. Its extent was defined by the presence of large sub-rounded boulders (illus 5). Within the grave, at a depth of 0.8m below the sub-cairn ground surface, a large soil stain was revealed (233). This was interpreted as the remains of a wholly degraded log-coffin, aligned approximately east/west; no wood survived. The log-coffin measured 2m by 0.32m; its eastern end had been shaped to a point, and its western end was squared off, giving the structure the appearance of a boat. Its walls, around 2–3cm thick for most of its length, increased in thickness towards the western, ‘rear’ end. The coffin was U-shaped in section, and along its base was a light blue sandy sediment (244). There was no trace of a lid or cover, although pollen analysis has indicated the former presence of bracken fronds, which may have been placed over the body. (See below, Clarke, for details of this and of other pollen in the coffin.)

Within the coffin were the remains of a severely degraded, putty-like femur, a fragment of another bone and parts of a molar tooth, all human

(SF21–2), thus providing positive evidence for the presence of an inhumation, and for the position of the skull towards the east, ‘front’ end. Judging from the distance between the tooth and the femur, the body must have been deposited in a crouched position, and it may well have been lying on its left side, with its head facing approximately south. Given the narrowness of the coffin, the corpse must have been tightly contracted (cf, for example, Bowthorpe: Lawson 1986). A bronze dagger (SF18, illus 10.1), with vestigial traces of its scabbard, was found adjacent to the northern edge of the log-coffin, behind the presumed position of the deceased’s waist. A sample of the scabbard’s animal skin cover produced a radiocarbon date of  $3385 \pm 45$  BP (1872–1533 cal BC at  $2\sigma$ , AA-29064: see below for discussion). Also present in the coffin fill was a residual Mesolithic flint flake (SF 19) and a second flint flake, now lost (SF 20). After removal of the artefacts and the remains of the coffin, 18 boulders (246) were found within the natural sand at the base of the grave. These appear to have been deliberately placed to support the coffin.

#### SHORT CIST 1

After removal of the topsoil within the southern half of the ring-ditch the plough-disturbed capstones of a cist aligned WNW/ESE were identified (context 193; illus 7). The capstones consisted of four rectangular Old Red Sandstone slabs, ranging in size up to 0.3m x 0.2m with five other smaller pieces. The side and end stones comprised nine upright slabs of rippled Old Red Sandstone averaging 0.6m long, 0.4m wide and 0.1m thick. The side stones had slumped to an angle of c 30–40° from vertical. Smaller members of the group had a mean size of 0.25 x 0.20 x 0.05m. The cist’s floor consisted of a discontinuous layer of laid beach cobbles, and the cut for the cist was 1.15m long, 0.85m wide and 0.45m deep. The fill within the feature (194) consisted of light orange to mid-brown sand with a small percentage of charcoal and traces of cremated bone (SF 30), too comminuted to allow firm identification. No pottery or other artefacts were recovered from the fill.

#### PIT CONTAINING CREMATION BURIAL

A collection of sub-rounded boulders marked the position of a relatively well-preserved cremation burial in a pit located 2m south from the wooden

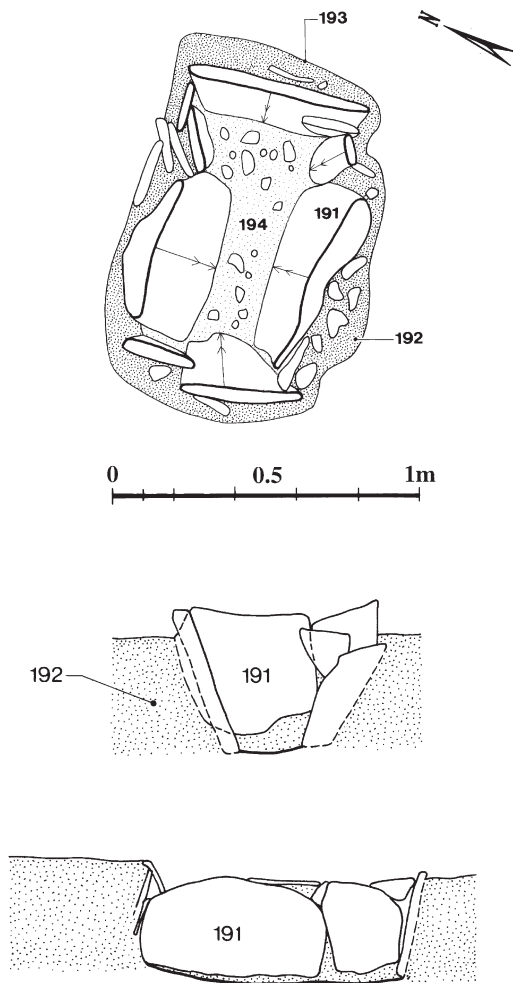

ILLUS 7 Plan and east- and south = facing (lower) elevations of Cist 1

coffin graves (context 047; illus 3). The pit was 0.30m in diameter and 0.15m deep. Some 1154.9g of cremated bone (SF 23), representing around 70% of the total expected bone weight after cremation (McKinley 1993), were recovered from the fill and from the stones covering the deposit; a few additional fragments of bone had been found during the initial evaluation work. A sample of oak charcoal from the fill produced a radiocarbon date of  $3845 \pm 50$  BP (2470–2143 cal BC at  $2\sigma$ , AA-29062; see below for comments). The bone (McKinley, below) represented the remains of an adult, c 18–45

years old. Gender identification was hampered by contradictory traits, but it is possible that the remains are those of a female. Soil sieving prior to the submission of samples to the palaeopathologist produced three burnt barbed and tanged arrowheads (SF 24–6, illus 14.3–5). In addition to these finds, a fragment of a cremated mandible belonging to a carnivore of dog or fox size was recovered, along with other possible fragments of animal bone. There was also residual Mesolithic material in the fill, in the form of an unburnt microlith fragment (SF 29). An undiagnostic burnt flint flake fragment from the pit (SF 28) was either part of the grave goods, or was also residual; and there was also a flint fragment (SF 27), found during the excavation but lost before specialist research commenced.

The presence of pyre debris is interpreted as indicating that cremation had taken place close to the grave site (McKinley, below); and the presence of the fruit of the Fat Hen species (*Chenopodium album* type) may or may not indicate that the ceremony occurred during the summer (Church below). Whether the ?dog/fox mandible represents a food offering, a hunting trophy or a hunting companion is unknown; dog remains have been found in a few other Bronze Age burials elsewhere (eg Weymouth, Dorset: Grinsell 1959, 142; cf burnt fox or badger bones in a barrow in the Bincombe area of Dorset: *ibid*, 93). A hunting connection would fit with the presence of the arrowheads in this grave. Clearly, both the arrowheads and the animal had accompanied the deceased on the pyre. If the deceased had indeed been female, such funerary associations would be unusual.

#### PIT 248

An oval pit measuring 2.1m by 0.8m and 0.7m deep was identified 0.3m north of Cist 1 (illus 3). Its fill consisted of a friable light grey-brown sand; there were no artefactual finds. At the base of this feature lay another circular pit measuring 0.8m in diameter with a depth of 0.9m. The fill of the lower pit consisted of orange sand with occasional pebbles. The function and date of both pits are unclear, although the oval pit is large enough to have been a grave for an inhumation burial. No bones or artefacts were found here, however.

PIT 253

This feature was observed as a shallow scoop cut into the subsoil, measuring 0.15m in diameter and 0.05m deep (illus 3). Its fill (252) comprised yellow-brown sand and gravel with occasional flecks of charcoal and one small piece of flint (SF 31). The function and date of this pit are unknown.

PIT 019

This feature, occupying a near-central position within the ring-ditch, measured 2m by 1.6m with a depth of 0.5m (illus 3). The fill (009) was a dark-brown sand containing several large boulders. No finds or skeletal remains were recovered. The function and date of this feature are unknown, although it is large enough to have been a pit grave for an inhumation burial.

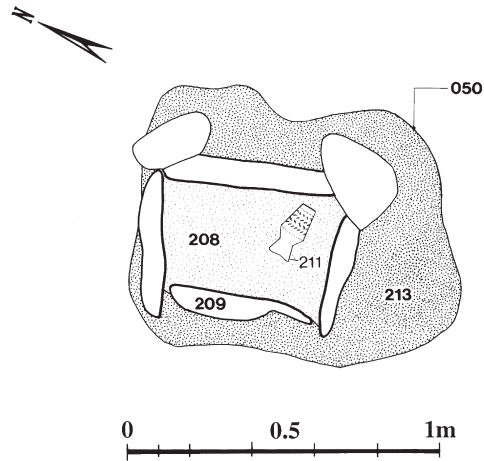

ARCHAEOLOGICAL FEATURES OUTSIDE THE RING-DITCH

SHORT CIST 2

Seven granite boulders formed the capstones over a short cist that was located 9m east of the ring-ditch on a NW/SE alignment (context 209; illus 8). The largest of these boulders measured 0.64m by 0.40m. Four slabs of Old Red Sandstone formed the side and end stones; the largest of these uprights was 0.6m by 0.4m and 4–5cm thick. When excavated the internal dimensions of the cist measured approximately 0.9m by 0.48m. The cist had been inserted into a rectangular pit defined by a cut measuring 1.0m by 0.5m. The cist fill consisted of a mid-brown to orange sand with fine gravel. A near-complete ‘step 5–6’ Beaker (SF 32, illus 10.3 and see below) was found on its side at the southern end of the cist. No traces of human remains were found but if, as seems likely, the cist had indeed been an inhumation grave, its occupant must have been crouched.

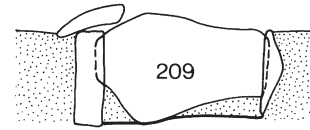
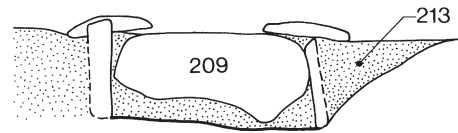

ILLUS 8 Plan and west- and north-facing (lower) elevations of Cist 2

CLUSTER OF PIT GRAVES (PITS 1–9) CONTAINING CREMATED BONE AND PYRE DEPOSITS

Nine pits were found in a cluster 14m west of the ring-ditch (illus 9). They occupied an area of about 3sq m and were variable in both depth and diameter. Most were circular or sub-circular on plan.

Diameters ranged from 0.30m to 0.67m and depth varied between as little as 0.05m and 0.56m; they had evidently been plough-truncated. One pit (Pit 3) cut another (Pit 2). All contained varying quantities of charcoal and cremated bone, the latter representing no more than one individual in each case, all adult. In one pit (Pit 7), the presence of a base of a coarse vessel, together with sherds of a second, smaller vessel (SF 45, below), suggests that one of these cremation burials had been placed in an upright urn, along with an accessory vessel.

Table 1 lists the pyre-goods recovered among the cremated bones during post-excavation analyses; for further information on the human remains, and their mode of deposition, see McKinley, below. Worthy of note are: fragments of a burnt antler pin from Pit 2 – probably some kind of



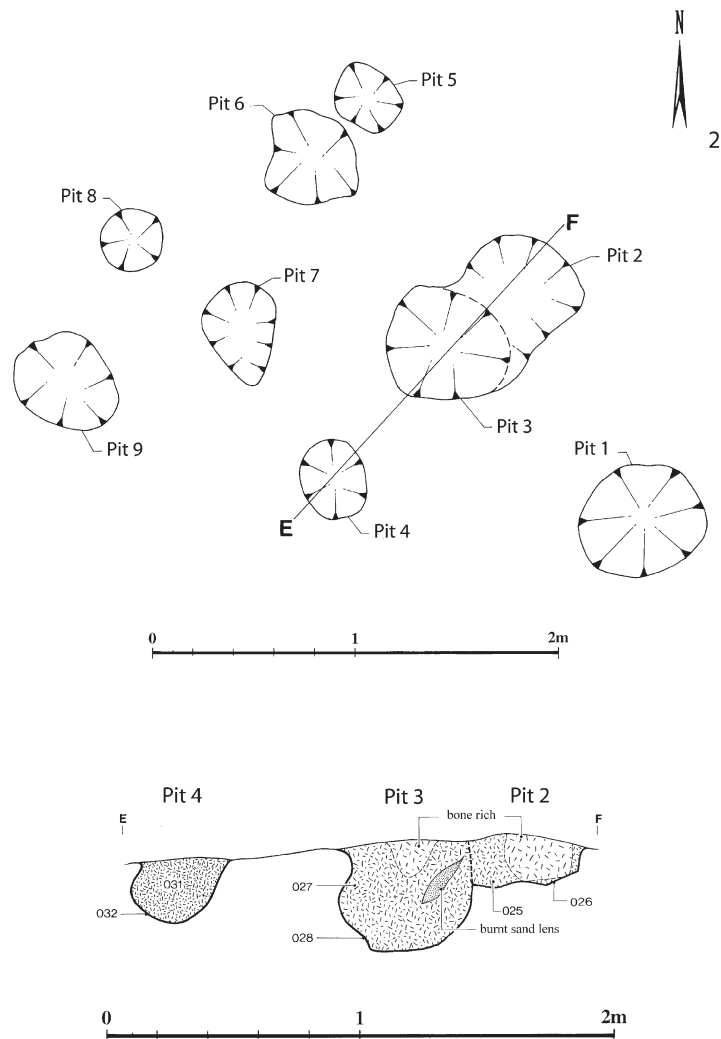

ILLUS 9 Plan of the pit cluster with cremation deposits and pyre debris, and section E–F (as marked on illus 3)

funerary garment fastener (SF 35, illus 14.1); a burnt flat two-holed bone toggle from Pit 3 (SF 37, illus 14.2) – again, probably a funerary garment fastener; a fragment of possibly worked animal bone from Pit 7, perhaps another funerary artefact (SF 44, not illustrated); the presence of unburnt and cremated animal bone in Pit 4, and of possible cremated animal bone in Pits 2 and 3 (species unidentifiable); a piece of hazel roundwood charcoal with a definite borehole (not twig-socket) running through it, from Pit 8 (SF 47, not

illustrated); and evidence for cut-marks on a skull fragment from Pit 3, made when the bone was ‘green’ (ie, living or shortly post-mortem; see McKinley, below, on its interpretation). Hazel charcoal from Pit 3 produced a radiocarbon date of  $3360 \pm 50$  BP (1750–1510 cal BC at  $2\sigma$ , GU-7590).

The abundant presence of pyre debris is taken to indicate that cremation had occurred in the vicinity (McKinley, below); and plant macrofossil evidence may indicate cremation during the summer, although this is not certain (Church, below).

TABLE 1

Dimensions and contents of the pit cluster with cremation and pyre deposits.  
See Table 9 for information on the human bone

Pit No	Dimensions/fill	Human remains	Pyre goods
1	0.66x0.56x0.30m. Black soil with charcoal fragments and comminuted charcoal dust	Adult, ?female (112.6g)	None found
2	0.58m diam, 0.56m deep. Charcoal-rich	Adult 18–45yrs (550g)	Antler pin, fragmented, burnt (SF 35, illus 14.1); possibly burnt animal bone
3	0.67x0.47x0.46m. Black soil with charcoal fragments and dust; fuel ash slag	Adult 18–30yrs, cut marks (812.7g)	Bone toggle, burnt (SF 37, illus 14.2); possibly burnt animal bone
4	0.67x0.33x0.25m. Charcoal fragments and dust	Adult 30–45yrs (615.2g)	Fragments of unburnt and burnt animal bone
5	0.32m diam; 0.19m deep. Charcoal fragments and dust; fuel ash slag	Subadult/adult (1.2g)	None found
6	0.40m diam; 0.25m deep	Subadult/adult (0.2g)	None found
7	0.45m diam; 0.14m deep. Charcoal fragments and dust	Adult, ?female (351.1g)	Worked animal bone? Sherds of two pots (SF45, not illus)
8	0.34m diam; 0.05m deep. Charcoal fragments and dust	Subadult/adult (0.4g)	None found
9	0.50m diam; 0.11m deep. Charcoal	Subadult/adult (2.7g)	None found

#### UNDATED PITS WITH EVIDENCE OF BURNING

One pit (context 190; illus 3) was found 10m north-west of the pit grave cluster and had a diameter of 0.65m and depth of 0.29m. Like the other pits it is likely to have been truncated. It was flanked by two holes that may have held upright stakes. The fill comprised a large amount of charcoal and fine fraction fuel ash; no cremated bone was present, and there was no sign of burning within the pit. It is unclear whether this pit was connected with the cremation process (cf McKinley 1997b, 132), or with other activities involving burning (eg cooking), but its small size would tend to preclude the former interpretation.

The second (227) was found approximately 8m north-east of the pit grave cluster and comprised a pair of interconnecting pits with a fill containing multiple laminations of charcoal and highly fired sand (illus 3). Oval in shape, this feature measured 2.5m by 1.0m and 0.6m deep. The highly fired red colour of the sand between the different horizons of charcoal suggests repeated episodes of burning within the pits. In the absence of burnt bone, it is impossible to say whether this had been connected with cremation (as an under-pyre draught scoop or pit: McKinley 1997b), or with cooking or some other activity.

The third (context 236) was found 5m north-east of the ring-ditch and was a shallow depression 0.04m deep and 0.4m in diameter containing flecks

of charcoal and unidentifiable comminuted fragments of burnt bone (SF 49). This feature showed signs of animal or root disturbance.

#### INDETERMINATE PITS

Eleven other features (contexts 185, 202, 204, 196, 199, 200, 227, 236, 238, 240 and 241; illus 3) were identified as pits. Of varying shape and depth, these were bereft of finds, charcoal and bone. Their function and date are indeterminate – except for pit (185), which contained a recent sheep burial.

#### THE BRONZE DAGGER FROM THE LOG-COFFIN

##### INTRODUCTION

Alison Sheridan

The remains of a dagger, in its composite organic scabbard (SF 18, illus 10.1, 11–13), were found adjacent to the northern wall of the log-coffin; from the vestigial traces of the coffin's occupant, it seems likely that it lay behind the back, at the waist. The only traces of the all-organic hilt were a 'shadow' of its omega-shaped bottom, clearly visible on the X-ray (illus 11), and tiny fragments adhering to the blade, which were too small for identification. Metallurgical analysis revealed that the blade and rivets are of bronze, and examination of the remains of the scabbard revealed that it had been made from laths of oak, with a cover of cattle skin sewn with

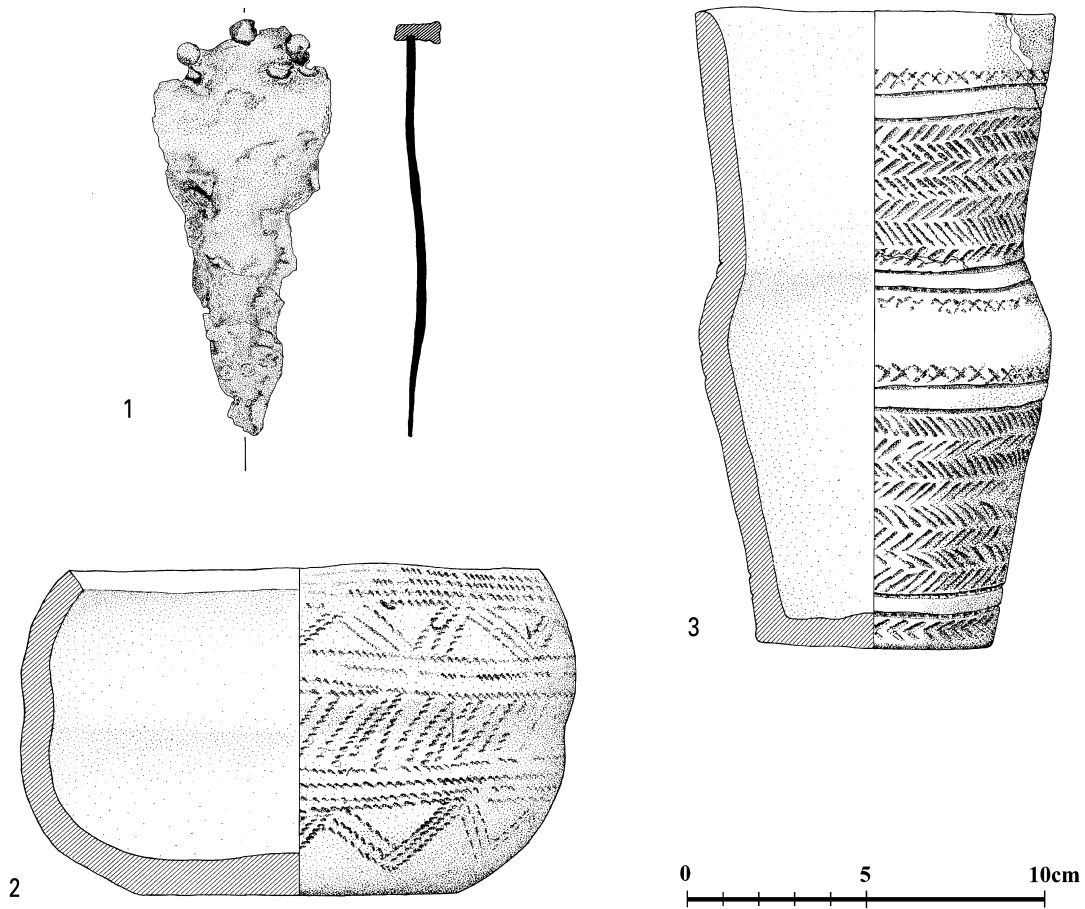

ILLUS 10 1 Dagger from the log-coffin (SF 18); 2 Food Vessel from the plank-built coffin (SF17); 3 Beaker from Cist 2 (SF32)

sinew thread (details below). A date of  $3385 \pm 45$  BP (1870–1520 cal BC at  $2\sigma$ , AA-29064) was obtained from the scabbard cover.

The blade survives to a length of c 113mm and width of c 50mm; it would originally have been a few millimetres larger than this. It is slender, and midway between tongue-shaped and triangular in shape. The tip has mostly corroded away, but the X-ray suggests that it had been gently rounded; the heel is rounded. The blade is flat, c 4mm thick where the metal is not laminating, and it has three plug rivets set around the omega-shaped hilt base. Its edges are too degraded to allow one to judge whether they had originally been bevelled; all one can say is that where they are least damaged there are no traces of a bevel.

The dagger may be assigned to Gerloff's 'Type Butterwick' (1975, 42ff), a widespread Early Bronze Age dagger type. Such daggers are characterized by blades around 120mm long and 55mm wide; three plug rivets; an omega-shaped hilt-mark; and, often, bevelled edges. They were probably cast in single-piece moulds. Scottish examples are known from Cleigh, Argyll & Bute and Ashgrove, Fife (ibid, 43), the latter with a horn hilt, pommel of sperm whale tooth and ribbed skin sheath or scabbard (Henshall 1964). Other examples discussed by Gerloff (1975, 42–4) have been found with hilts of horn (Butterwick and Rudston, North Yorkshire) and wood (Hundleton, Dyfed), and with scabbards (ie a rigid cover, including wooden plates: eg Newton Grange, Derbyshire).



ILLUS 11 X-ray showing the dagger in its block of sediment prior to excavation in the laboratory. Note the omega-shaped hilt mark. (Copyright Trustees of the National Museums of Scotland)

Flat riveted daggers, of which 'Type Butterwick' examples are the most numerous, represent the earliest bronze dagger type in Britain (Needham 1998, 187–9). Table 2 presents the currently-available dating evidence for 'Type Butterwick' and other flat riveted daggers.

From this it is clear that the Seafield West date is distinctly later than the others, which tend to cluster around 2300–1900 BC. (The clearly anomalous Ashgrove date may be discounted on the basis of its large standard deviation and uncertainties surrounding the 'vegetable matter' sample.) Only the Manor Farm, Lancashire dates are comparable,

and here the excavator has urged caution in accepting their association with the dagger, for reasons explained in the excavation report (Olivier 1987, 141, 153). Thus, either the Seafield West dagger is genuinely a very late example, or there is a flaw in the date. Given that the expected date for the Irish Bowl Food Vessel from the adjacent plank-built coffin is c 2200–1950 BC (see below), the latter explanation seems more likely.

#### THE METAL OF THE DAGGER

Peter Northover

##### *Sampling methods and analysis*

The state of the blade meant that only a drilled sample could be taken and any metallographic examination was therefore ruled out. The sample was removed from the upper part of the blade using a hand-held modelmaker's electric drill with a 0.7mm diameter bit and labelled NMS 751; it was then hot-mounted in a carbon-filled thermosetting resin, ground and polished to a 1µm diameter finish. Analysis was carried out using electron probe microanalysis with wavelength dispersive spectrometry. Operating conditions were an accelerating voltage of 25kV, a beam current of 30nA and an X-ray take-off angle of 62°. Counting times were 10s per element, and pure element and mineral standards were used. Thirteen elements were analysed (Table 3); detection limits were 100–200ppm for most elements, except 300ppm for gold and c 0.20% for arsenic. This last was due to the compromises made with the instrument to avoid the well-known interference between the strongest lines in the lead and arsenic spectra, the lead  $L\alpha$  and arsenic  $K\alpha$  lines. For lead the strong  $M\alpha$  line could be used but for arsenic it was necessary to use the weak  $K\beta$  line, hence the degradation in performance. A more sensitive analysis for arsenic could be made but the extra time and costs were not justified here.

Because of the limited amount of sound metal in the sample it was only possible to make two analyses, each over 30x50µm. Individual analyses and their means, normalized to 100%, are given in weight % (1% = 1000 ppm) in Table 3.

##### *Results: the metal*

The dagger blade is formed from a lead-free medium tin bronze with 9.34% tin; the close similarities

TABLE 2  
Radiocarbon dates for flat riveted daggers. Based on Needham 1998 (table 7.8), with additions. Dates calibrated using OxCal v3.5 (Bronk Ramsey 2000), using atmospheric data from Stuiver et al (1998)

Findspot	Dagger type (Gerloff 1975)	Sample	Date BP	Date cal BC at 2σ	Lab No	Reference
Seafield West, Highland	Butterwick	Cattle skin from scabbard	3385 ± 45	1870–1840 (2.1%) 1780–1520 (93.3%)	AA-29064	This paper
Gravelly Guy, Stanton Harcourt, Oxfordshire	Butterwick (with copper rivets)	Human bone, unburnt	3709 ± 35	2200–2010 (91.0%) 2000–1970 (4.4%)	UB-3122	Gerloff 1993; in press
Ashgrove, Fife	Butterwick	Plant remains in cist	2950 ± 150	1500–800 (95.4%)	Q-764	Henshall 1964; 1968; Gerloff 1975, no 27; Needham 1998, 189
Manor Farm (burial 1), Lancashire	Butterwick (cf Variants Eynsham and Garrowby)	Human bone, unburnt Associated animal bone	3270 ± 80 3450 ± 70	1740–1390 (95.4%) 1940–1600 (93.0%) 1570–1530 (2.4%)	HAR-5628 HAR-5661	Olivier 1987; Needham 1998, 189
Barrow Hills (barrow 3), Radley, Oxfordshire	Milston (East Kennet variant)	Human bone, unburnt	3785 ± 90	2500–1950 (95.4%)	OxA-4355	Needham 1998, 189
Rameidry Farm, Fife	Milston	Animal skin from scabbard	3725 ± 40	2280–2250 (3.4%) 2230–2220 (1.0%) 2210–2010 (88.2%) 2000–1970 (2.9%)	weighted mean of GU-9574A & B	Baker et al forthcoming
Collesie, Fife	Masterton	Ox skin from scabbard Cremated bone	3690 ± 80 3695 ± 45	2350–1750 (95.4%) 2210–1940 (95.4%)	OxA-4510 GrA-19054	Sheridan et al 1995 Sheridan 2002b
Gristhorpe, N Yorkshire	Merthyr Mawr (Variant Parwich)	Oak branches on log-coffin	3590 ± 100	2900–2100 (95.4%)	HAR-4424	Gerloff 1975, no 55; Needham 1998, 189
Tavelty, Aberdeenshire	Fragment of small copper/copper alloy blade, assumed to be dagger or knife-dagger	Human bone, unburnt	3710 ± 70	2300–1880 (95.4%)	GU-2169	Ralston 1996

TABLE 3  
Analyses of the Seafield dagger

	Fe	Co	Ni	Cu	Zn	As	Sb	Sn	Ag	Bi	Pb	Au	S
NMS 751/1	0.03	0.01	0.00	90.10	0.00	0.18	0.00	9.21	0.19	0.00	0.02	0.06	0.21
NMS 751/2	0.03	0.00	0.00	90.10	0.00	0.15	0.00	9.46	0.23	0.02	0.00	0.00	0.00
NMS 751	0.03	0.01	0.00	90.10	0.00	0.17	0.00	9.34	0.21	0.01	0.01	0.03	0.11

between the two individual analyses demonstrate the homogeneity of the metal (Table 3). This is to be expected from the degree of working and annealing noted in other blades of 'Type Butterwick' (Northover 1999). The principal impurities are 0.17% arsenic, 0.21% silver and 0.11% sulphur. Also present were very small traces of iron, cobalt, lead and bismuth, all very close to their limits of detection. It will be noted that the arsenic content is below the detection limit cited above; however, a qualitative check of the X-ray spectra was made bearing in mind the low levels of lead, and arsenic was definitely present.

### Discussion

As noted above, the radiocarbon dating for the organic material originating from the dagger scabbard is apparently late for a flat dagger although, of course, the scabbard could be significantly younger than the dagger. Given the way in which Early Bronze Age impurity patterns change with time (Northover 1980; O'Brien et al 1990) the analyses of the Seafield West dagger have the potential to help us assess its date of manufacture. The composition must also be reviewed in comparison with other analysed flat dagger types, primarily 'Type Butterwick', to which it has been assigned (Tables 4 & 5).

The impurity pattern for arsenic and silver places the metal in Group 'F' in the scheme devised by Northover to describe Early Bronze Age metalwork (Northover 1980). This group has so far proven to be most closely associated with the period

of developed flat axes, that is those with a median bevel to the blade, and especially those of Irish origin. In Britain analysed examples so far appear to be spread out along the western seaboard. This connection would certainly be consistent with the unusual presence of an Irish Bowl Food Vessel in the adjacent grave. Dating the initiation of either bronze with this impurity, or of developed flat axes, can at best be indirect. The undoubtedly early Butterwick type dagger from Gravelly Guy, Stanton Harcourt, Oxfordshire (Tables 4 & 5), with its combination of bronze blade and copper rivets, has the arsenic/antimony/silver (As/Sb/Ag or Group 'A') impurity pattern characteristic of a very great majority of copper metalwork of Irish origin, and also characteristic of the earliest bronze where it is associated with simple flat axes, flat daggers and Breaghwy halberds (Northover, forthcoming). The dating of dagger and other associations (Northover 1999) shows that production of this metal was dying out by 1900 BC.

The question then is whether, and to what extent, the production of 'F' metal overlapped with that of 'A'. One relevant date comes from the wedge tomb site at Toormore, Co Cork, which also produced a small hoard of a developed flat axe and two pieces of raw copper related to 'F' metal. Three dates suggest activity on the site in the period 1800–1400 BC on the horizon on which the metal was deposited (O'Brien et al 1990; O'Brien 1999). These dates indicate that 'F' metal could have continued in use throughout the first half of the second millennium BC. Examination of the available

TABLE 4  
Analyses of 'type Butterwick' daggers. Numbers in italics indicate result affected by corrosion

Gerloff No	Provenance & metal type	Fe	Co	Ni	Cu	Zn	As	Sb	Sn	Ag	Bi	Pb	Au	S
–	Seafield West (F)	0.03	0.01	0.00	90.10	0.00	0.17	0.00	9.34	0.21	0.01	0.01	0.03	0.11
–	Gravelly Guy, Oxfordshire (A)	0.00	0.01	0.02	89.26	0.00	1.99	0.61	7.83	0.18	0.02	0.02	0.04	0.02
20	Butterwick, N Yorkshire (A)	0.00		0.03	84.80	0.00	0.85	0.23	8.60	0.33	0.00	0.00		
34	Hundleton, Dyfed (A)	0.02	0.00	0.06	<i>81.38</i>	0.00	0.74	0.22	<i>17.25</i>	0.08		0.00	0.25	
39	Darowen, Clwyd (F)	0.00	0.00	0.00	87.81	0.00	0.75	0.00	11.36	0.08		0.00	0.00	
41	Eynsham, Oxfordshire (F)	0.00	0.00	0.04	88.28	0.00	1.10	0.05	9.06	0.05	0.02	0.00	0.00	

TABLE 5  
Analyses of copper and bronze daggers

Gerloff No	Type	Provenance	Museum/ current location	Fe	Co	Ni	Cu	Zn	As	Sb	Sn	Ag	Bi	Pb	Au	S
20	B	Butterwick, N Yorkshire	BM 1879.12-9.374	0.00	0.00	0.03	84.80	0.00	0.85	0.23	8.60	0.33	0.00	0.00	0.00	
34	B	Hundleton, Dyfed	NMGW 24.273	0.02	0.00	0.06	81.38	0.00	0.74	0.22	17.25	0.08		0.00	0.25	
39	B	Darowen, Clwyd	NMGW 47.164.172	0.00	0.00	0.00	87.81	0.00	0.75	0.00	11.36	0.08		0.00	0.00	
39A	B	Darowen	NMGW 47.164.173	0.00	0.00	0.11	86.24	0.00	1.86	0.43	10.94	0.42		0.00	0.00	
	B	Gravelly Guy, Oxfordshire	OAU	0.00	0.01	0.02	89.26	0.00	1.99	0.61	7.83	0.18	0.02	0.02	0.04	0.02
	B	Gravelly Guy (rivet)	OAU	0.02	0.00	0.02	98.64	0.01	0.58	0.40	0.14	0.11	0.03	0.03	0.01	0.01
	B	Gravelly Guy (rivet)	OAU	0.00	0.01	0.02	98.87	0.00	0.39	0.30	0.24	0.11	0.02	0.01	0.03	0.00
	B	Gravelly Guy (pommel rivet)	OAU	0.05	0.01	0.01	98.07	0.03	0.49	0.96	0.00	0.25	0.06	0.05	0.01	0.01
	B	Gravelly Guy (pommel rivet)	OAU	0.10	0.01	0.02	97.65	0.01	1.09	0.77	0.02	0.28	0.02	0.01	0.00	0.02
41	B	Eynsham, Oxfordshire	Ash 1953.111B	0.00	0.00	0.04	89.68	0.00	1.10	0.05	9.06	0.05	0.02	0.00	0.00	
	B	Seafeld West	CFA	0.03	0.01	0.00	90.11	0.00	0.17	0.00	9.34	0.21	0.01	0.01	0.11	
48	MM	Merthyr Mawr, Mid Glamorgan	NMGW 01.361.2	0.02	0.00	0.14	89.48	0.00	1.14	0.00	9.17	0.05	0.00	0.00	0.00	
53	MM	Rosedale, N Yorkshire	BM	0.05	0.00	0.12	88.06	0.00	0.15	0.00	11.60	0.02	0.00	0.00	0.00	
60	M	Auchnacree, Angus	NMS X.DQ.259	0.01	0.00	0.00	98.31	0.00	0.89	0.52	>10.00	0.27	0.00	0.00	0.00	
62	EK	East Kennet, Wiltshire	BM P1964.12-1.52	0.03	0.00	0.01	83.85	0.00	1.00	0.50	14.40	0.20	0.02	0.00	0.00	
	EK	East Kennet (rivet)	BM P1964.12-1.52	0.01	0.00	0.13	97.81	0.00	2.00	0.03	0.00	0.02	0.01	0.00	0.00	
63	EK	Radley (barrow 3), Oxfordshire	Ash 1945.112	0.10	0.01	0.05	90.19	0.00	0.35	0.02	9.25	0.00	0.02	0.01	0.00	
	EK	Radley (barrow 3)	Ash 1945.112	0.01	0.00	0.02	88.70	0.00	0.70	0.00	10.45	0.00	0.08	0.04	0.00	
	EK	Radley (barrow 3) (rivet)	Ash 1945.112	0.01	0.03	0.04	94.29	0.01	0.05	0.00	5.43	0.12	0.01	0.01	0.00	
	EK	Radley (barrow 3) (rivet)	Ash 1945.112	0.00	0.01	0.04	94.01	0.02	0.05	0.00	5.74	0.05	0.01	0.07	0.00	
65	EK	Auchnacree, Angus	NMS X.EQ.260	0.03	0.00	0.00	98.66	0.00	0.70	0.37	>10.00	0.24	0.00	0.00	0.00	
66	EK	Amesbury G85, Wiltshire	Salisbury 97/1930	0.01	0.00	0.04	86.23	0.04	2.06	0.00	11.60	0.01	0.01	0.00	0.00	
69	EK	Wimborne St Giles G9, Dorset	Devizes DM1070	0.00	0.00	0.01	92.65	0.00	0.20	0.24	6.70	0.20	0.00	0.00	0.00	
	EK	Rameldry, Fife	NMS X.EQ.1098	0.05	0.01	0.01	87.08	0.02	0.24	0.26	12.12	0.10	0.04	0.07	0.00	
	EK	Do. (rivet)	NMS X.EQ.1098a	0.03	0.00	0.01	88.00	0.01	0.22	0.26	11.30	0.11	0.00	0.03	0.01	0.02
70	Mas v	Masterton, Fife	NMS X.EQ.640	0.00	0.00	0.04	99.34	0.02	0.01	0.01	≈10.00	0.16	0.00	0.38	0.00	0.04
84	Mas v	Collessie, Fife	NMS X.EQ.52	0.01	0.00	0.06	84.49	0.00	0.10	0.27	11.88	1.01	0.00	1.95	0.02	0.21
86	mfb	Aylesford, Kent	Maidstone	0.03	0.00	0.06	88.66	0.00	1.40	0.00	9.70	0.08	0.00	0.07	0.00	
88	mfb	Cowbridge, S Glamorgan	NMGW 20.435	0.00	0.00	0.05	88.99	0.00	0.85	0.00	10.11	0.00	0.00	0.00	0.00	
	mfb	Cowbridge (rivet)	NMGW 20.435	0.00	0.01	0.00	91.53	0.00	0.10	0.00	8.37	0.00	0.00	0.00	0.00	
90	mfb	Whitford, Clwyd	NMGW 23.195.1	0.00	0.01	0.24	79.83	0.00	3.07	0.27	16.14	0.15	0.00	0.00	0.30	
	mfb	Whitford (rivet)	NMGW 23.195.1	0.00	0.01	0.14	86.61	0.00	3.33	0.11	9.37	0.00	0.00	0.20	0.24	

Key: Types: B = Butterwick; MM = Merthyr Mawr; M = Milston; EK = East Kennet; Mas v = Masterton, variant; mfb = miscellaneous flat blade.  
Museums: BM = British Museum; NMGW = National Museums & Galleries of Wales; OAU = Oxford Archaeological Unit; Ash = Ashmolean; CFA = Centre for Field Archaeology; NMS = National Museums of Scotland. Numbers in italics indicate result affected by corrosion.

databases of Irish Early Bronze Age analyses confirms this in that 'F' metal is present in a significant proportion of 'Type Derryniggin' and other flanged axes, the most recent types of the Irish Early Bronze Age. The production of 'F' metal is also currently of interest; the radiocarbon dates from the mine on Ross Island, Co Kerry show production of ore continuing until about 1800 BC, probably after production of 'A' metal ceased. The lead isotope signature for the Toormore objects can be matched with the 'Blue Hole' at Ross Island and suggests a possible source for 'F' metal towards the middle of the first half of the millennium. The range of compositions of the ores from Ross Island certainly makes possible the production of at least some metal with the very low antimony of the 'F' type (Northover et al 2001). Thus, an 'F' metal composition is not inconsistent with the most probable date range for the Seafield West dagger, even though that date is late in relation both to the Irish Bowl Food Vessel and the probable date range for the manufacture of Butterwick daggers.

We may now examine how this dagger blade compares with others of its type, and also with other flat dagger types (Tables 4 & 5). To date seven Type Butterwick daggers have been analysed. Of these, three (Butterwick, North Yorkshire; Hundleston, Dyfed; and the aforementioned Gravelly Guy dagger) have an 'A' metal (As/Sb/Ag) impurity pattern, although with varying arsenic contents. The Gravelly Guy dagger has a radiocarbon date range of 2200–2010 BC which agrees very well with the combination of an 'A' bronze blade with 'A' copper rivets, and the associated Step 6 Beaker. A fourth, fragmentary blade from Darowen, Powys has an 'A' composition with a slightly raised nickel content and is probably also of Type Butterwick. The two daggers remaining, beside that from Seafield, are a second dagger from Darowen and one from Eynsham, Oxfordshire. Both have impurity patterns that can be connected with the 'F' group but have lower silver and higher arsenic than the Seafield West dagger. Both groups have broadly similar tin contents, the range being 7.8%–11.4%, with the Seafield West dagger in the middle. Other flat dagger types also show similar impurity patterns and tin contents, although a small number have a 'B' impurity pattern with arsenic and nickel as the main impurities.

When attention is specifically focused on Scottish flat daggers, 'A' and 'F' metals have the same

prominence with 'A' metal in the Type Milston dagger from Auchnacree, Angus (Gerloff 1975, no 60), the Type East Kennet dagger from Rameldry, Fife (Northover, 2003) and the Masterton variant from Collessie, Fife (Henshall 1968), while a very similar As/Ag pattern with 0.16% silver was identified in the blade from Masterton, Fife itself (*ibid*). The range of tin contents is again similar to that in the Type Butterwick daggers.

### *Conclusions*

The Seafield West dagger is made from a medium tin bronze with 9.3% tin and has an As/Ag impurity pattern (Group 'F'). This metal can be associated with production in Ireland in the first half of the second millennium BC. In the early part of this period Ross Island may have been a source for 'F' metal but had ceased to be by 1800 BC, by which time other sources would have been active. None of this is inconsistent with the date of the Seafield West scabbard which, in any case, may not have been as old as the dagger. However, the date is late by the yardstick of the best dated flat daggers of Butterwick and other types. Even the use of 'F' metal could be seen as late for Type Butterwick, placing the Seafield West dagger at the end of the production life of that type. The 'F' composition also suggests an Irish connection for the source of the metal, a connection perhaps reinforced by the presence of the Irish Bowl Food Vessel.

### THE SCABBARD

Thea Gabra-Sanders, Michael Cressey & Ciara Clarke

Vestigial traces of a composite organic scabbard were found attaching to the blade. Enough survived to demonstrate that it had had an inner, rigid layer made of thin laths of oak, and an outer layer of animal skin. Several fragments of the latter had sets of small, closely-spaced holes running in a straight line, and the discovery of a c 21mm long detached fragment of tightly twisted two-ply animal fibre (almost certainly sinew), 0.7mm wide (*illus* 12), may represent the thread that had been sewn through these holes. Unfortunately, the animal skin fragments are too small to allow us to determine whether the sewing was simply to join the ends of a sheet or sheets of skin, to fix the skin to the wood,



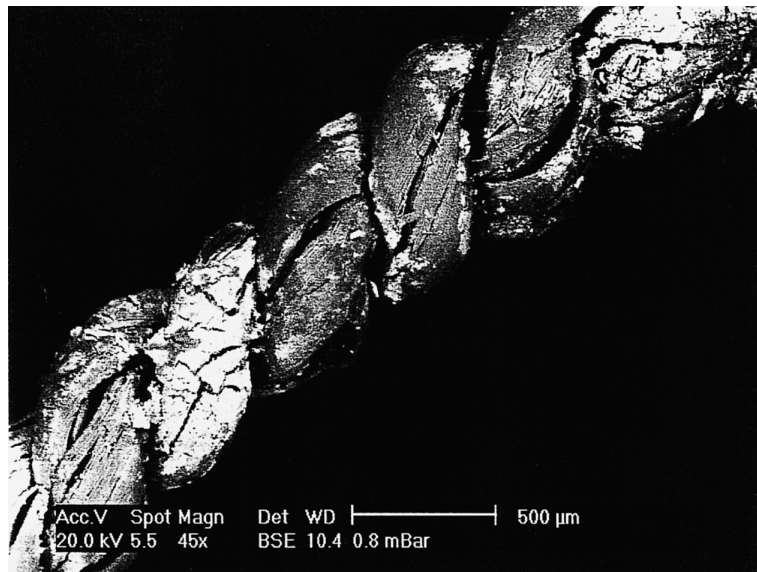

ILLUS 12 Photomicrograph of the sinew thread from the dagger scabbard  
(Copyright University of Edinburgh)

or for decorative effect (cf Ashgrove: Henshall 1964; 1968), or indeed any combination of these.

A small fragment of animal skin from the scabbard was found to have retained some hairs on one side, and this was subjected to detailed examination (by TG-S) after scanning electron microphotographs had been taken (illus 13). The hairs, which are straight, have been examined for diameter measurements. These provide a mean diameter of 51 μm and a hair diameter range of 26–70 μm. Using the micrographs, the scale pattern was compared with Appleyard’s pictures of cattle hair and the hairs are suggested to be ‘bovine’ (Appleyard 1978). Ryder (pers comm) would prefer to say primitive cattle hair. The diameter range of 26–70 μ strongly suggests that a primitive coat (M Ryder, pers comm) was used in the manufacture of the dagger scabbard.

Table 6 compares this result with those obtained from three Scottish Early Bronze Age dagger scabbards/sheaths (from Ashgrove, Masterton and Collessie, Fife: Ryder 1964a). Comparative data are also provided by a Late Bronze Age sword scabbard from Pyotdykes, Tayside (Ryder 1964b), and a Middle Bronze Age ‘mystery object’ consisting partly of matted cattle hair found in 1991 at Sheshader, Lewis (Ryder, forthcoming).

TABLE 6

Comparisons of cattle hair measurements from the scabbard and from other Scottish Bronze Age artefacts. Measurements for Seafield West provided by T G-S; all others by M L Ryder (pers comm)

	Mean diameter (μm)	Diameter range (μm)
‘Bovine’		
Ashgrove	18	18–46
Masterton	19	8–42
Pyotdykes	14	6–48
Seafield West	51	26–70
‘Ox’		
Collessie	49	10–108
	Mean and std dev (μm)	
‘Bovine’		
Sheshader	59.2 ± 12.9	40–80, 86, 100

## POTTERY

### Alison Sheridan

#### THE FOOD VESSEL FROM THE PLANK-BUILT COFFIN

An intact bipartite Irish Bowl Food Vessel (SF 17; illus 10.2) was found upright towards the eastern end of the coffin, close to several flint artefacts. The bowl is 95mm high, with a rim diameter of

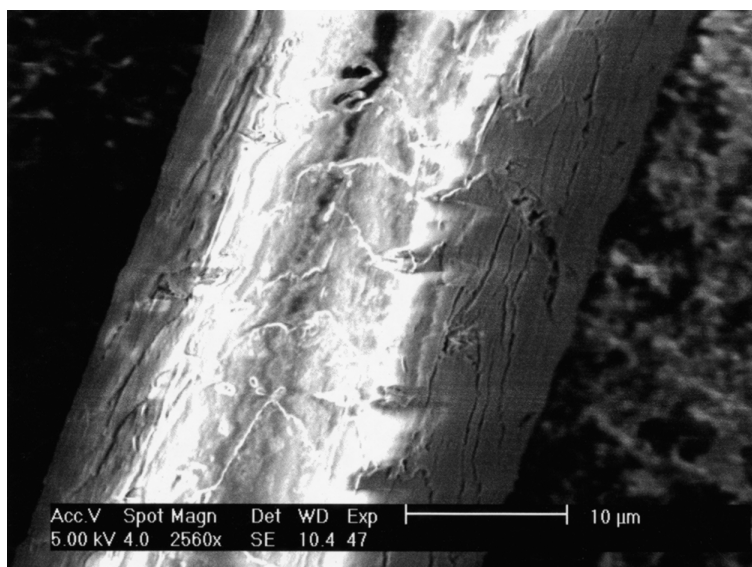

ILLUS 13 Photomicrograph of the cattle hair from the dagger scabbard (Copyright University of Edinburgh)

128–38mm (the pot's shape being not truly circular), and wall thickness of c 8mm. The rim is bevelled internally; the body is waisted at mid-height; and the base is dished. The bowl is decorated with impressions of thin twisted cord. On the rim bevel, these occur as very faint transverse lines, while on the body they are arranged into two zones, divided at the waist by a band of diagonal lines. The upper zone consists of a triple running chevron design, fringed at the top and bottom by sets of four and three horizontal lines respectively; the lower panel has an upper fringe of four horizontal lines, and a repeat of the chevron design.

The bowl's exterior surface is a mottled light brown, buff and orange-buff; the core colour is not visible. The interior is a darker version of the exterior colour, with traces of a crumbly blackish-brown encrustation – almost certainly the organic residue left from the evaporation of the pot's former, liquid, contents – extending between the base and rim. (Further, tiny patches of this encrustation were also originally present on the exterior, but crumbled away.) The fabric is fine-textured and fairly soft, and the surfaces have been carefully smoothed. The pot contains numerous small angular grits, up to 2.5 x 2.5mm in size and at a density of 10–15%, including a shiny mineral (probably feldspar or quartz) and mica platelets.

A sample of the organic residue produced a radiocarbon date of  $2625 \pm 45$  BP (900–560 cal BC, AA-29063).

This is a classic example of an Irish Bowl Food Vessel, comparable in shape and decoration with several Irish examples (eg Grange, Co Roscommon; Newry, Co Down; 'Ireland': Ó Ríordáin & Waddell 1993, nos 55, 46, no locality 8), and with examples from Barsloisnoch and Dunchraigaig from the Kilmartin area of Argyll (Christison & Anderson 1905; RCAHMS 1988, pl 22a, d). Its presence in north-east Scotland is remarkable, because pots of this type are uncommon in Scotland as a whole, and are particularly rare outside Argyll. Food Vessels of any kind are markedly less common than Beakers in the North-East (see, for example, Walker 1966), and no other example of an Irish Bowl is known from this part of Scotland.

A recent project undertaken by Brindley and Lanting to radiocarbon date Irish Early Bronze Age pottery (Brindley 1995; 2001; Lanting & Brindley 1998) has established that Bowl Food Vessels are likely to have been in use there around 2200–1950 BC. For example, human bone associated with two bipartite Bowls from a pit grave at Keenoge, Co Meath, has been dated to  $3685 \pm 45$  BP (2200–1930 cal BC at  $2\sigma$ , GrN-12272), while Bowl-associated dates of between  $3770 \pm 70$  BP

(2460–1970 cal BC at 2 $\sigma$ , OxA-2664) and 3600  $\pm$  40 BP (2130–1770 cal BC at 2 $\sigma$ , GrA-13331) have been obtained from the Grange cemetery. More specifically, Bowls with the running chevron design as seen at Seafield West tend to date to c 2000 BC (A Brindley, pers comm). The date obtained from the organic encrustation of the Seafield West pot is therefore clearly anomalous.

The fact that both the Food Vessel and the dagger from the adjacent grave have unmistakable Irish connections raises the question of the nature of the contact with Ireland. This will be discussed in the final section of this paper.

#### THE BEAKER FROM CIST 2

A very slender, long-necked Beaker (SF 32; illus 10.3), which may originally have stood upright in the cist but was on its side when found, with the upper part of one side crushed inwards by the ingress of pebbly sand into the cist at some point in the past. The pot is 175mm high, with diameters at rim, belly and base of 102, 101 and 65mm respectively and a wall thickness of c 8.5mm. The rim is internally bevelled and the neck is straight and slightly angled, kinking out to a well-defined belly around half way down the pot. The base is slightly dished on its exterior and slightly domed inside. The exterior of the vessel is decorated from the neck to the base with impressions made by two rectangular-toothed combs, one (used for horizontal lines) c 30mm long, the other (used for herringbone and criss-cross designs) c 10mm long. The overall design consists of two panels of herringbone, each framed above and below with pairs of spaced horizontal lines and fringes of a loose criss-cross pattern.

The exterior is a mottled light brown-buff-orange-brown, with one dark brown patch; the core black; and the interior mid- to dark grey-brown. There are no obvious signs of any encrustation, other than tiny discontinuous black patches on the interior just above the base, and traces of a brownish matter on the exterior in a similar position. The surfaces have been carefully smoothed prior to decoration, and the exterior has a slip-like appearance, possibly made by wet-smoothing. Inclusions are angular, small (up to 3x2mm), abundant (10–15% density) and similar to those seen in the Food Vessel, including numerous mica platelets.

This pot has no very close parallels, but in its shape and decoration it is nearest to Clarke's 'Late

Northern Long-Necked Beakers – N3(L)' (Clarke 1970) and to those of steps 5–6 in the schemes of Lanting and van der Waals (1972, fig 4) and Shepherd (1986, illus 20). Comparative dating evidence is very sparse. The British Museum Beaker radiocarbon dating programme (Kinnes et al 1991) produced two dates for 'N3(L)/step 6 Beakers from Angus: Cookston Farm, 3800  $\pm$  50 BP (2460–2040 cal BC at 2 $\sigma$ , BM-2523) and Middle Brighty Farm, 3730  $\pm$  50 BP (2290–1970 cal BC at 2 $\sigma$ , BM-2524); but concluded that no neat typochronological sequence for Beaker pottery as a whole could be defined.

#### FRAGMENTS OF POSSIBLE URN AND ACCESSORY VESSEL FROM PIT 7

These comprise one large sherd (SF 45; not illustrated), forming over half of the base of a large, friable, coarse pot plus a handful of other sherds, fragments and crumbs from the same area of this pot. Also present is one rimsherd (formerly in four pieces) plus a fragment, which appear to represent a second, smaller pot.

The basal pieces come from a large vessel whose diameter at this point is 90mm and whose maximum thickness is 30mm. The wall flares and decreases rapidly in thickness from 22mm at the wall-base junction to 12mm at a point 35mm above this. The fabric is pinkish-brown to buff-brown throughout, and is friable, with a hackly fracture. The surfaces are fairly smooth, with a slip-like appearance that may have been produced by wet-smoothing; there is no decoration. Inclusions comprise angular and sub-angular fragments of stone up to c 10 x 4mm; most are of a hard, blackish, speckled type of rock, with shiny minerals.

The rimsherd, also undecorated, comes from a vessel whose rim diameter is unlikely to exceed 180mm. The rim is gently squared off and, judging from the sherd's curvature, must have sloped inwards. The wall thickness is 9–12mm. The fabric is a paler, more buff colour than that of the base sherds, although it is similarly friable; the exterior and interior surfaces are darker than the core. The surfaces may have been wet-smoothed. Inclusions are similar in size and type to those seen in the base sherd.

That more than one pot is represented is suggested by the diameters of the vessels: the splay on the first pot suggests that its rim diameter would

have exceeded 180mm. It was a cinerary urn of some kind, but one cannot determine which type, beyond confirming that it is unlikely to have been a Bucket Urn, even though it had probably been deposited upright. In view of its findspot, context and intimate association with the urn, the smaller pot could have been a large accessory vessel; examples of such an association include one found inverted inside a Collared Urn from Westwood, Fife (Jervise 1867). However, the near-complete destruction of these pots makes any further comment unwise.

## ANTLER AND BONE ARTEFACTS

Michael Cressey & Alison Sheridan

### THE ANTLER PIN FROM PIT 2

The fragmentary remains of a burnt antler pin (SF 35; illus 14.1) were found during specialist examination of the cremated bone from Pit 2. It was recovered in five pieces, none of which fit together, but an overall length of c 150mm can be estimated. The head, unperforated, is 7mm wide. Burnt pins of bone and antler have been found with Bronze Age cremation deposits, both urned and un-urned, in Britain and Ireland (eg at Moncreiffe, Perthshire: Close-Brooks 1985). As they are invariably burnt, they are assumed to have been fasteners for funerary garments worn during cremation.

### THE BONE TOGGLE FROM PIT 3

A complete, flat, elongated lozenge-shaped bone toggle with two perforations, 25mm long and 9mm wide, burnt, was recovered during dry sieving (SF 37; illus 14.2). A close parallel for this object comes from the nearby site of Raigmore, c 700m west of Seafield West, and was associated with cremated remains inside a Cordoned Urn (Simpson 1996, illus 18.3). Other toggles of this and other shapes, made of bone and antler, have been found with Bronze Age cremation deposits elsewhere in Britain and Ireland, associated with various urn types (eg Piggott 1958; Close-Brooks 1985; Barnatt 1994; Simpson 1996, 74). The Seafield West specimen is unusual only in coming from an un-urned deposit. Since all the examples from these contexts have been burnt, they are assumed to have been fasteners for funerary garments – an alternative form of fastener to the pin. (At Moncreiffe, uniquely, both

types of fastener were found together in a Cordoned Urn: Close-Brooks 1985.) Whether the flat perforated examples had been used as toggles as such, or as sliders for draw strings, is unclear, but the other variants are likely to have functioned as toggles.

Some indication of the date of bone toggles has been provided by the National Museums' of Scotland *Dating Cremated Bones Project*, supported by the Society of Antiquaries of Scotland and the University of Groningen (Sheridan 2001; 2002a). Three dates have so far been obtained from cremated bone directly associated with bone toggles. The example most similar to the Seafield West toggle, a four-perforation example from Kinneil Mill, Stirling (Marriott 1968, fig 4), is dated to  $3420 \pm 45$  BP (1880–1600 cal BC at  $2\sigma$ , GrA-19425). A collared toggle from Mains of Carnousie, Turriff, Aberdeenshire (Longworth 1984, 305, no 1903, pl 238) dates to  $3520 \pm 45$  BP (1960–1690 cal BC at  $2\sigma$ , GrA-19049); and a bow tie-shaped example from Beech Hill House, Coupar Angus, Perth & Kinross (Stevenson 1995, illus 10), to  $3665 \pm 45$  BP (2200–1910 cal BC at  $2\sigma$ , GrA-19426). This suggests that toggles had a currency of several centuries.

## THE CHIPPED STONE

Graeme Warren

Nineteen artefacts from Seafield West were presented for analysis. The surface collections from field-walking and further surface material held in Inverness Museum, considered by Bill Finlayson to indicate Mesolithic activity, were not included. Unfortunately three stratified pieces (SF 13, 20 and 27) are recorded as lost.

The assemblage consists solely of flint and includes three distinct themes: a residual Mesolithic assemblage; a set of burnt barbed and tanged arrowheads deposited with a cremation burial; and finally some large, mostly retouched, flakes deposited within the plank-built coffin. The individual pieces are described in Table 8.

### MESOLITHIC ACTIVITY

The Mesolithic material is represented, in the main, by patinated and edge-damaged material. Although the overall number of finds is small they include two microliths and a microburin, as well as blades, regular flakes and a small, heavily worked blade core. The raw material appears to have been small

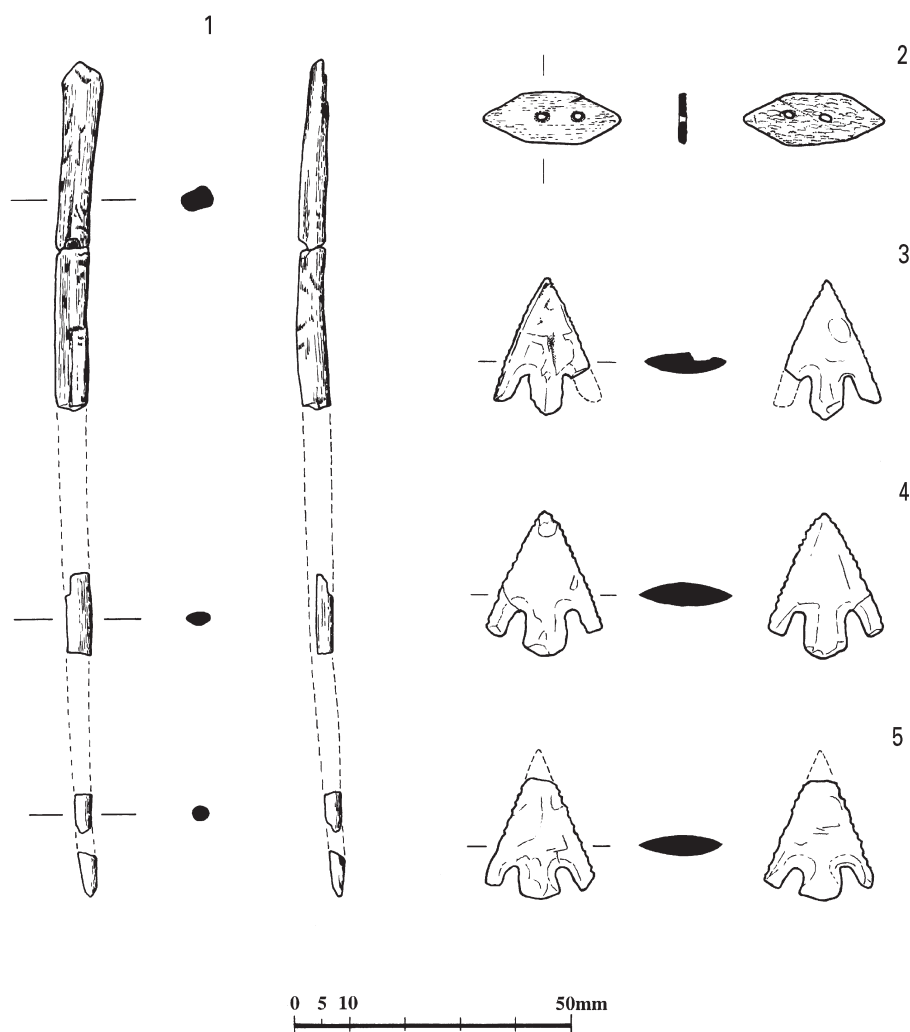

ILLUS 14 Finds from the cremation burials, all burnt: 1 Antler pin fragments from Pit 2 (SF 35); 2 Bone toggle from Pit 3 (SF 37); 3-5 Barbed and tanged arrowheads from the cremation burial inside the ring ditch (SF 24-6)

TABLE 7  
Condition of flint by type

	Burnt	Fresh	Patinated	Total
Blade			1	1
Core			1	1
Flake, irregular	1		4	5
Flake, regular	1	1	1	3
Retouched	3	3	3	6

rolled pebbles and a number of removals demonstrate platform preparation and small neat platforms. The core has been heavily worked, with

a second platform replacing an exhausted first. The microliths are both narrow-blade: one (SF 31) is an unusual form, akin to a scalene triangle but with a hinge fracture forming the short blunted edge; the other (SF 29) is fragmentary. The latter, recovered alongside three burnt arrowheads from within the cremation grave inside the ring-ditch, is fresh rather than patinated, presumably reflecting local depositional conditions. A light scraper, on a fine flake (SF 9), is also presumably Mesolithic in date. This material is clearly residual, and provides further

TABLE 8

## The chipped stone

SF No	Size (mm)	Context/ illus no	Notes
Mesolithic flints			
5	20x9x7	cairn	Grey, tertiary irregular flake. Patinated, edge damaged
6	12x3x3	cairn	<i>Microburin</i> : white tertiary blade with notching retouch. Patinated, edge-damaged. Proximal microburin two notches to right, break facet below second. Break facet is complex to left hand side. Platform small, indicates some isolation (4x1mm)
7	18x13x2	cairn	White, patinated, edge damaged proximal fragment of irregular flake split through the platform.
8	31x10x5	cairn	White, patinated, edge damaged secondary blade fragment. Distal portion of overshoot blade with small area of rolled cortex at extreme distal.
9	20x15x4	cairn	<i>Scraper: convex, end of flake, thin</i> : white-blue patinated regular tertiary flake. Very light flake with curving blunting retouch at distal. Retouch fine, and generally short, forming convex scraper edge with slight shoulder. Overall form is slightly irregular. Platform demonstrates neat isolation and is small (3x1mm).
10	21x11x5	cairn	Cream-white highly patinated irregular flake with blade-like feel (possible mis-hit/flawed removal?). Platform demonstrates careful isolation and is small (4x1mm).
11	12x11x2	fill of plank-built coffin	Cream distal fragment of a patinated edge-damaged regular tertiary flake – broken since patination.
12	19x21x13	fill of plank-built coffin	<i>Core: 2 platform</i> : white grey part patinated/part fresh secondary core. On a small pebble of grey flint, partly patinated and with small area of battered cortex visible. The two platforms are at c 90 degrees to each other, on opposite sides of pebble; one appears to have succeeded the other. Removals mainly small flakes and irregular blades, some difficulties with hinging noted.
19	22x12x6	fill of log-coffin grave	White patinated edge-damaged irregular tertiary flake. Long, thin platform 7x2mm. Some preparation.
28	17x11x4	pit with cremation deposit within ring-ditch	White-grey, burnt, regular secondary flake fragment with one small area of thin, rolled exterior.
29	8x4x2	pit with cremation deposit within ring-ditch	<i>Microlith: indeterminate</i> : honey retouched tertiary blade fragment. Distal fragment of triangular sectioned microlith with retouch along one side. Possibly backed blade
31	17x5x2	pit (context 253) within ring-ditch	<i>Microlith: scalene?/backed blade</i> : white patinated edge-damaged retouched tertiary blade fragment. Unusual small microlith. Of scalene form but retouch runs along hypotenuse and short arm made up of hinge fracture at distal of parent blade/flake. Slight edge damage towards tip on unblunted angle, but not at tip itself.
38	18x14x3	Pit 3	Thermal flake
Barbed and tanged arrowheads from cremation grave inside ring-ditch			
24	25x17x3	illus 11.3	White, heavily burnt regular tertiary flake with extensive invasive retouch and with developed lustre from heat. Heat fractures removed from one face near tip. One barb missing. Central tang rounded and elongated, surviving tang angular. Edges very straight.
25	26x21x4	illus 11.4	White, heavily burnt regular tertiary flake with extensive invasive retouch. Almost complete, with one refitting break to a barb. Central tang is square with a slightly rounded end, barbs slightly angular. Edges very straight
26	22x19x4	illus 11.5	White, heavily burnt regular tertiary flake with extensive invasive retouch. Tip missing (lost SF 27 may be missing tip). Central tang flares slightly, and is longer than the two rounded barbs. Straight edges.

## Artefacts deposited in the plank-built coffin

13			Flint flake; lost
14	57x44x10	illus 11.1	<i>Knife</i> : grey regular secondary flake with edge damage and retouch. Large flake of high-quality grey flint from rolled pebble source. Large platform (9x24mm) indicating soft hammer. Retouch along left hand side neat and formal, forming long straight knife-edge. Smaller ventral flakes either anticipate final form of artefact or are removed after the main flake, making piece very ergonomic.
15	45x41x12	illus 11.2	<i>Scraper</i> : <i>convex, irregular</i> : cream honey regular secondary flake with edge damage and retouch. Large flake of flint from rolled pebble; identical material to SF 16. Platform cortical. Irregular retouch along right difficult to distinguish from edge damage, more regular curved scraper edge formed at 'distal' – although termination is not even and large area to the left of the scraper edge is of unusual form. Retouch short and overall feel of the artefact not one of high formality.
16	36x29x5	illus 11.3	<i>Flake</i> : cream-honey fresh regular tertiary flake of identical material to SF15

confirmation of the Mesolithic activity on site indicated by the surface collections. No structural evidence of Mesolithic activity was identified. The significance of this material will be discussed in the final part of this paper.

#### BARBED AND TANGED ARROWHEADS FROM THE CREMATION GRAVE INSIDE THE RING-DITCH

These three fine arrowheads are very well burnt, with a glossy sheen. They have light damage to tips and tangs, which may well result simply from burning, and it is not clear that they have been used; indeed high quality pieces like this may well have been made specifically for symbolic uses (Edmonds 1995). A single burnt flake and a small microlith fragment found in the cremation grave are likely to be residual or to result from disturbance, and the three arrowheads seem to have been a deliberate funerary deposit, possibly burnt on the pyre with the dead.

Finds of Early Bronze Age barbed and tanged arrowheads, especially in association with Beaker burials, are relatively common throughout Britain and numerous examples are known from north-east Scotland, for example at Tavelty Farm, Kintore (Ralston 1996), where two barbed and tanged arrowheads were discovered with an inhumation dating to  $3710 \pm 70$  BP (2300–1880 cal BC at  $2\sigma$ , GU-2169). Barbed and tanged arrowheads have often been considered to form part of a package of archery-related objects closely tied into male identity during the Early Bronze Age (Edmonds & Thomas 1987, 192–5; Edmonds 1995, 141ff). Some of these artefacts are exceptionally fine: for example a Beaker-associated male inhumation from Culdu-thel, Inverness included examples that 'may reflect

the labour of people who were accorded a measure of status as specialists' (ibid, 143). The deposition of three fine artefacts onto the funeral pyre, and their incorporation into the funerary deposit indicates the importance of these objects to the definition of the identity of the dead by the community of the living.

#### ARTEFACTS DEPOSITED IN THE PLANK-BUILT COFFIN

Leaving aside the residual Mesolithic flake and core (SF 11, 12) accidentally incorporated in the grave fill, four flint artefacts in this coffin appear to represent original grave goods (illus 15). The raw material used is much larger than for the Mesolithic finds, and indicates significantly different routines of procurement. Traditions of working have also changed, the large platform on SF 14 for example indicating the use of direct soft hammer percussion. It is difficult to interpret the reasons for the deposition of these particular artefacts in the burial, although similar objects have been found with other Food Vessel-associated burials (eg Simpson 1968). Although the knife is a fine artefact the other pieces are not especially elaborate (although it should be noted that SF 15 and 16 may have been struck from the same parent material). In any case their deliberate incorporation in this deposit indicates the explicit symbolic manipulation of stone-craft as part of the funerary ritual.

#### THE CREMATED HUMAN BONE

Jacqueline I McKinley

#### INTRODUCTION

Cremated bone from 18 contexts was received for analysis. Two of these were associated with the

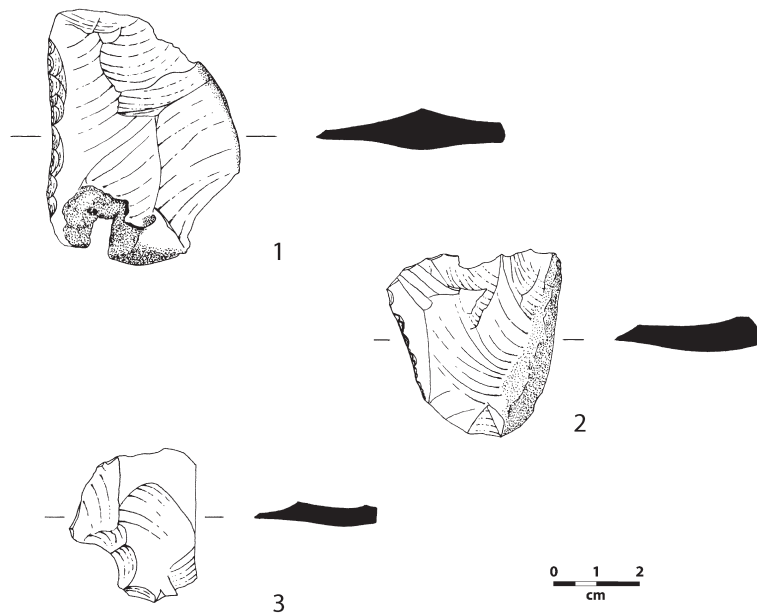

ILLUS 15 Flints from the plank-built coffin. 1 Edge-retouched knife (SF 14); 2 Convex scraper (SF 15); 3 Flake from the same parent cobble as SF 15 (SF 16)

cremation grave inside the ring-ditch. Most of the others derived from the cluster of pits to the west of the ring-ditch. The remainder were recorded from the fills of the ring-ditch and the cairn, where a small amount of scattered bone was found. Some unstratified cremated bone, found during the evaluation phase in the area of the pit cluster, was also examined.

#### METHODS

All cremation-related contexts were subject to 100% soil recovery and wet sieved to 1mm fraction size. The cremated bone together with any other archaeological inclusions were separated from the >4mm fraction residues in post-excavation. Osteological analysis followed the writer's standard procedure for the examination of cremated bone (McKinley 1989; 1994a). The <4mm fraction residues were scanned to extract any identifiable skeletal elements. Fragments of animal bone and pyre goods were extracted. Age was assessed from the stage of skeletal and tooth development (van Beek 1983; McMinn & Hutchings 1985; Webb & Suchey 1985) and the general degree of age-related changes to the bone (Bass 1987). Sex was ascertained from the

sexually dimorphic traits of the skeleton (Gejvall 1981; Bass 1987). A combination and scoring of traits were used in order to overcome any methodological bias. Levels of reliability reflect the quantity and quality of available traits on which to base the assessment. Pathological lesions and morphological variations were recorded and diagnoses suggested where appropriate. Anatomical terminology is in accordance with Gray (1977) and McMinn and Hutchings (1985).

#### RESULTS

Table 9 summarizes the results. Full details of all the identified bones, together with tabulated data on bone weights and percentages by fraction size and identified skeletal element groups, are available in the archive report.

The features within the ring-ditch appeared to be intact. However, the surrounding area had been subjected to intensive ploughing over a prolonged period and, consequently, it is probable that the features outside the ring-ditch will have experienced an unknown level of truncation, and hence potential loss of bone. The condition of the bone was variable. Of the four contexts where unstratified



TABLE 9  
Summary of results from skeletal analyses of the cremated bones

Context	Type	Total wt. (g)	Age	Sex	Pathology
Ring ditch fill	r	1.2	subadult/adult		
Pit 1	?un b/rpd	112.6	adult	??female	
Pit 2	un b	550.0	adult 18–45 yr	?male	pitting – T ap
Pit 3	un b	812.7	adult 18–30 yr		cut-marks — vault; m v — wormian bone
Pit 4	un b	615.2	adult 30–45 yr		o p — atlas, axis, T/L body, auricular surface; pitting – auricular surface
Pit 5	rpd	1.2	subadult/adult		
Pit 6	rpd	0.2	subadult/adult		
Pit 7	un b	351.1	adult	?female	hypercementosis
Pit 8	?rpd	0.4	subadult/adult		
Pit 9	?rpd	2.7	subadult/adult		
C2–6	u/s;r	8.1	adult		
C047	un b	1154.9	adult 18–45yr		Sch. — T/L; m.v. – metopic suture
C11/13					

KEY: C2–6= from area of pit C047 within ring ditch, found during evaluation phase; C047, C11/13= pit inside ring ditch (11/13 = upper fill and covering stones); u/s = unstratified; r = redeposited; un b = un-urned burial; rpd = redeposited pyre debris; ?? possible, ? probable; o p = odontoid process; Sch. = Schmorl's node; m v = morphological variation; T = thoracic; L = lumbar; ap = articular process; FAS = fuel ash slag

bone was found (2–6, in the area of the pit cluster), only the bone from context 6 appeared worn, which suggests a different origin from the rest of this redeposited bone. Bone from four of the graves in the pit cluster showed varying degrees of degradation, that from Pits 1, 3 and 4 being slightly worn, that from Pit 2 being moderately worn. Such bone degradation is the result of high soil acidity and is not unexpected where the soil matrix is of a sandy nature and the bone unprotected (for example, by an urn). The inclusion of large quantities of charcoal within the fills (see below) should have had some neutralizing effect. However, there is no noticeable decrease in degradation to charcoal-stained bone (indicative of the close proximity of the two archaeological components within the burial environment), with that from Pit 1 being heavily stained, that from Pits 2 and 3 moderately and slightly stained respectively. The bone from the pit grave within the ring-ditch (047) was not stained and appeared unworn. Further evidence of the adverse effects of the acid soil is the noticeable lack of spongy bone (articular surfaces, vertebrae etc) among the fragments from Pit 3. Spongy bone is more prone to disintegration during excavation as a result of degradation in acid soils (McKinley 1997a, 245).

A minimum of five, possibly six individuals can be confirmed from the analysis of all the cremated bone. All were adults, with a minimum of one male

and one, possibly two, females. It cannot be confidently confirmed or refuted that the other features within the cluster of pits represent graves (see below), but the bone within them does not indicate the presence of any infants or juveniles. It is, however, possible that immature bone may have suffered preferential destruction in the acid soil. Given the likelihood of truncation, it is not impossible that more, shallow, graves have been completely lost, but there is no reason to suppose that such graves would contain the remains of immature individuals. None of the contexts contained the remains of more than one individual.

A limited number of pathological lesions was observed; most were associated with some form of degenerative joint disease (Rogers & Waldron 1995). One small fragment of cranial vault (c 9.3mm square) from Pit 3 has two parallel cut marks 2.5mm apart across the exocranial surface. The cuts are sharp, with a steeper angled edge on one side, and appear to have been inflicted in green bone (that is, prior to cremation). It was not possible to conclude whether the marks were made pre- or post-mortem. As it was not possible to ascertain the exact location of this small skull fragment within the parietal or frontal vault, interpretation of the probable cause of the cuts is difficult, but the absence of similar marks on any of the 75 other vault fragments recovered suggests no extensive

involvement of the skull as might be expected, for example, in scalping (Mays & Steele 1996).

The bone was almost uniformly buff-white in colour, indicative of a high degree of oxidation (efficient cremation). The only burial which may confidently be described as undisturbed, from within the ring-ditch, contained a high weight of bone, representing a large proportion (c 70%) of what would have been the total weight of bone after cremation (McKinley 1993). The relatively high bone weight may well be associated with the position of this burial within the confines of the ring-ditch for ritual as well as, or rather than, practical purposes (McKinley 1997b). Many factors may affect the size of bone fragments (McKinley 1994b). In this instance, the high soil acidity and un-urned form of burial will have contributed to a reduction in bone fragment size, the largest recorded fragment being 66mm. There is no evidence to support deliberate breakage of bone prior to burial. In each burial, bone elements from each skeletal area were present, there being no apparent deliberate selection of particular bones for burial.

Fragments of cremated worked antler and bone pyre goods were recovered from two burials (see above). Fragments of cremated animal bone, also comprising pyre goods, were recovered from two, possibly four, burials, one of which also contained fragments of unburnt animal bone. The recovery of cremated animal bone from Bronze Age cremation burials is not unusual, including c 13% of those previously analysed by the writer (c 190 burials). The species (dog/fox size carnivore) in the burial within the ring-ditch is, however, unusual.

### *Discussion*

The burial within the ring-ditch and all the cremation-related features within the western group contained some re-deposited pyre debris, incorporating both fine grain and coarser grained carbonized wood. The presence of pyre debris in the features indicates the close proximity of the pyre sites to the place of burial, and is a relatively common theme in the Bronze Age cremation ritual (McKinley 1997b). The pyre debris in a grave fill and the burial generally represent remains from the same cremation.

The fills of Pits 2 and 3 (illus 9) are noticeably different from the others in the group. In Pit 3, most of the grave was first filled with pyre debris,

including fragments of cremated bone not collected for burial, prior to deposition of a concentration of bone ('the burial') in the upper fill. Unfortunately, since the bone from the concentration and that from the rest of the fill were recovered as one context, the relative proportions of bone in the concentration and that in the rest of the fill is not known. A similar mode of deposition was noted in Pit 2, though in this instance the burial appears to have been made first – probably in some form of organic container – then pyre debris incorporated in the backfill around it.

Since pyre debris commonly includes fragments of cremated bone and pyre goods not collected for burial, and cremation burials sometimes include some fragments of charcoal, it can be difficult, in some instances, to ascertain whether the fill of a feature represents the remains of a burial or a deposit of pyre debris. Generally, a burial will be represented by a concentration of bone, whereas cremated bone in pyre debris will be dispersed and mixed with the other archaeological components. The fills of some of the features in the pit cluster have the appearance of re-deposited pyre debris as opposed to actual burials. However, it is not improbable that these pits did represent graves, the burials within which have been removed by ploughing, leaving only the base of the cut with its primary fill of pyre debris. The factors which would lend support to this interpretation are: pyre debris was recovered from features which clearly are graves; in at least one grave the 'burial' was located above the primary fill of pyre debris; and there is known to have been some level of truncation within this area of the site.

## CHARCOAL IDENTIFICATION

Michael Cressey

Charcoal identification was undertaken, firstly, to determine the overall species composition of the types of wood used in cremation pyres, secondly, to obtain an insight into local woodland cover and, finally, to identify suitable specimens for radiocarbon dating. The results are shown in Table 10.

### IDENTIFICATION

Charcoal was collected by hand during excavation and by post-excavation flotation of bulk soil

TABLE 10  
Charcoal species and weight from the pyre deposits

Charcoal species	Total weight (g)	% weight	Context
Hazel ( <i>Corylus avellana</i> )	155	71.3	Pits 1, 2, 3, 4, 7, 8
Oak ( <i>Quercus sp</i> )	31.6	14.5	Pits 1, 5, pit in ring ditch (047)
Birch ( <i>Betula sp</i> )	18.8	8.6	Pits 3, 4, 5, 6, 8
Cherry ( <i>Prunus</i> type)	5.7	2.6	Pit 1
Alder ( <i>Alnus glutinosa</i> )	5.2	2.3	Pit 3
Pine ( <i>Pinus sylvestris</i> )	0.5	0.2	Fill of plank-built coffin
Apple ( <i>Pomoideae</i> type)	0.41	0.1	Pit 4
Total	217.2		

samples. Identifications were made using a binocular microscope at magnifications ranging between x10–40. Generally identifications were carried out on transverse cross-sections on charcoal measuring between 4–6mm. Anatomical keys listed in Schweingruber (1990), and in-house reference charcoal and slide-mounted micro-sections were used to aid identification. Asymmetry and morphological characteristics were recorded. Large samples of charcoal (over 100g) were split in a riffle-box to produce sub-samples in order to speed up the sampling process. Extraneous non-charcoal material such as cinder and modern plant debris was removed during analyses. Heavily mineralized and vitrified charcoal was discarded owing to the limitations on identifying this material. In this report ‘roundwood’ is used to refer to branch wood.

#### ANALYSES OF RESULTS

The results of charcoal analyses from the pyre debris deposits have been grouped together to provide a broad overview of the species used as pyre fuel. Approximately 200g of charcoal have been examined from the pyre deposits, providing a 10% sample. The charcoal from individual pits is shown by species in Table 10.

The charcoal was derived from roundwood. Pits 1 and 2 contained hazel charcoal with a diameter of 40mm; the other contexts contained small roundwood (on average 10–20mm diameter). Pit 8 contained a piece of hazel charcoal with a diameter of 25mm and a 5mm diameter transverse bore hole. The function of this object prior to cremation cannot be determined, but it is clear that the hole is not a natural feature.

The charcoal assemblage from the pit cluster provides a very rough indication of the type of wood that was available for exploitation in the vicinity of Seafield West. Hazel is the most abundant

species, followed by birch. These species, along with oak, cherry and pine, were probably exploited from the drier areas around the site while alder would certainly have been obtained from the margins of a stream or mire within the floodplain south-west of the fluvio-glacial terrace.

#### PLANT REMAINS FROM THE CREMATION-RELATED DEPOSITS

##### Mike Church

Nine samples were submitted for analysis, all of which produced small numbers of carbonized plant macrofossils. The results are presented in Table 11.

#### METHOD

The bulk samples were taken from the pit fills when the excavator deemed this necessary, a strategy known as ‘judgement sampling’ (Jones 1991). Though ‘judgement sampling’ does not statistically represent the sampled population (that is, the archaeological contexts across the site) the samples processed can present a qualitative picture of the type of plant macrofossils found within the pit fills and presumably the plants used as pyre fuel and pyre goods.

The bulk samples were processed using a flotation tank (Kenward et al 1980) with the residue held by a 1.0mm net and the flot caught by 1.0mm and 0.3mm sieves respectively. All the flots and residues were dried and sorted using a low-powered stereo/binocular microscope at x15–80 magnification. All identifications were checked against botanical literature and modern reference material from collections in the Department of Archaeology, University of Edinburgh. Nomenclature follows *Flora Europaea* (Robinson 1998) with ecological information taken from Clapham et al (1989), Stace (1991) and Grime et al (1988).

TABLE 11  
Carbonized plant macrofossils

Context		C047	Pit 1	Pit 2	Pit 3	Pit 4	Pit 5	Pit 6	Pit 7	Pit 9
Sample volume (litres)		4	10	11	16	11	17	11	9	8
<i>Cultivated species</i>	<i>Plant part</i>									
<i>Hordeum</i>										
H. sp	caryopsis				1					
H. hulled	caryopsis						14			
H. naked	caryopsis						2			
Cereal indeterminate	caryopsis						2			
Cereal/monocotyledon (>2mm)	culm node								11	5
Cereal/monocotyledon (<2mm)	culm node		1				2	2		5
Cereal/monocotyledon (>2mm)	culm base		1	7	2	3	18	4	8	1
Cereal/monocotyledon (<2mm)	culm base		1	4			36	2	1	3
Indeterminate (>2mm)	rhizome						1			
<i>Wild species</i>										
<i>Polygonum</i> sp	fruit			4						
<i>Polygonum aviculare</i> type	fruit			4				1	1	2
<i>Chenopodium album</i> type	fruit	26		13			1	9		3
<i>Euphorbia helioscopia</i> L	seed			2						1
<i>Stellaria media</i> (L) Vill	seed			1			1			
<i>Poaceae</i> undiff (medium)	caryopsis			2			3			
Indeterminate	seed/fruit			4			1			
Fungal sclerotia	sclerotia			p				p		p
<i>Quantifiable components</i>		26	3	41	3	3	81	18	21	20

Key: C047 = pit inside ring ditch; p = present

## RESULTS AND DISCUSSION

Table 11 presents the carbonized plant macrofossils recovered from the samples. Each sample was similar in composition and was taken from a similar context type (a deposit with cremated remains) and so the analysis is made for the assemblage as a whole. It is likely that the charcoal-rich fills of the pit grave cluster contain the charcoal and plant macrofossils preserved during the burning of plant material as fuel for the cremation.

The assemblage is dominated by culm bases and nodes of cereal/monocotyledon type, which presumably represent the burning of grasses and weeds during the cremation. Cereal plant macrofossils are rare with a single poorly-preserved grain of barley (*Hordeum* sp) recovered from Pit 3, and a few slightly better preserved grains of naked and hulled barley recovered from Pit 5. These could represent the deliberate placement and burning of foodstuffs as part of the cremation ceremony. However, it is also possible that the grain represents the likely surviving remains from the burning of straw with parts of the ear still attached, the straw acting as an effective starter fuel for cremation. Also, Fat Hen (*Chenopodium album* type) has been proposed as a crop in its own right, especially in times of famine

(Dimbleby 1978), and so may again represent the deliberate placement and burning of foodstuffs as part of the cremation rite. The recovery of both naked and hulled barley, as well as Fat Hen, is consistent with the Bronze Age archaeobotanical evidence for Scotland, as outlined by Boyd (1988).

The fruit and seeds from wild plants include knotgrass (*Polygonum* spp), the aforementioned Fat Hen (*Chenopodium album* type), Sun Spurge (*Euphorbia helioscopia* L), Common Chickweed (*Stellaria media* (L) Vill) and grasses (*Poaceae* undiff). These genera and species are common on cultivated or disturbed ground or open grasslands and therefore support the evidence of the culm bases and nodes for the burning on the cremation pyre of whole plants of weeds and grasses. It is interesting to note that there is a certain amount of uniformity across the contexts with a couple of plants, such as Fat Hen and knotgrass, recovered from four or five different contexts. This may represent the gathering of plants from a single habitat, such as a cultivated field or managed grassland, as part of a repeated and established cremation rite. The possible use as fuel of grass material from the borders of cultivated ground or grassland was also noted by Dickson (1997) from

the pyre debris deposits of a Bronze Age cairn at Sketewan, Perth & Kinross and by Robinson (1988) from other Bronze Age graves with cremated remains across Britain. In this context, it is interesting to note that all of the genera and species recovered from the pit grave cluster seed from mid- to late summer, which may represent the season in which the cremations took place. However, it must be noted that the lack of diversity and low counts of plant macrofossils preclude definite conclusions. Also, hay and straw can be stored following harvesting in late summer, to be used, and in this case burnt, at other times of the year.

## POLLEN ANALYSES

Ciara Clarke

Due to the presence of well-preserved organic remains in the two coffin burials and the Beaker, palynological analysis on sediments from these features was undertaken. Samples were analysed from: the vegetative material around the dagger in the log-coffin; the basal fill of the log-coffin; the blackish encrusted deposit and the sandy sediment inside the Food Vessel; and the sandy fill of the Beaker.

## METHOD

Sub-samples were subjected to standard palynological preparation procedures (Moore et al 1991). Statistically robust counts of c 300 grains (Maher 1981) were targeted for each sample. Pollen and spore identification was aided by the pollen keys of Moore et al (1991), Bennett (1994) and Bennett et al (1994), and by consultation of type material held in the Department of Archaeology, University of Edinburgh. Nomenclature follows Bennett et al (1994). Fungal spores were recorded according to Clarke (1994). Pollen preservation was recorded according to Cushing (1967).

## RESULTS

### *Log-coffin burial* (dagger sample)

Using a stereo microscope nine samples for pollen analysis were examined from the vegetative material around the dagger. All the samples comprised at least 90% bracken spores (*Pteridium aquilinum*). It is likely that the material surrounding the dagger consisted predominantly of bracken fronds with

other pollen taxa encountered representing background species. To the author's knowledge, botanical material of this precise nature has not been recovered from other Scottish dagger burials.

### *Log-coffin burial* (basal fill)

It was anticipated that the superb preservation of the botanical material in the area of the dagger might be mirrored in other areas of the coffin. In particular it was hoped that palynological analysis of material from the floor of the feature might enhance our knowledge of flora associated with Bronze Age burials. The paucity of the skeletal remains meant that the position of the body could only be approximated. Therefore, it was not possible to sample for pollen in relation to the original location of the corpse (cf Clarke 1999). Instead the floor of the coffin was gridded into 0.2m squares and samples for palynological analysis were taken from each square. Samples were taken from both inside and outside the area of the coffin stain and also from the subsoil around the feature. Fifteen samples were analysed, 14 from the log-coffin floor and one sample from subsoil around the feature. Of these, six yielded pollen sums of c 300 grains. All samples outwith the area of the stain were barren, as was one sample from the interior and the sample of the subsoil.

The six palynologically productive samples came from the area circumscribed by the coffin stain. The pollen assemblage was dominated by cf dogwood (*Cornus*), buttercup (*Ranunculus* undiff), alder (*Alnus glutinosa*), hazel/myrtle (*Corylus avellana* type) and bracken (*Pteridium aquilinum*). Pollen of grasses (*Poaceae*) was present at low levels in some samples. Other taxa were present in trace amounts. Holocene vegetation evidence from north-east Scotland suggests pressure on the landscape from grazing with increasing blanket mire development as a result of climatic deterioration around this time (Tipping 1994b, 24–33). While the pollen taxa from the cist floor could derive from an open landscape, the low level of *Poaceae* and the virtual absence of dominant heathland vegetation such as *Calluna*, coupled with the dominance of a restricted number of taxa, suggests that some selection process has operated on the coffin pollen assemblage. Previous explanations for distinctive pollen assemblages from Bronze Age cists include a food or drink spilt from a vessel (Dickson 1978); a

covering or mat of vegetation; body contents; and floral tributes (Whittington 1993; 1997; Tipping 1994a; Clarke 1999). In this instance the absence of a Food Vessel or a Beaker from the log-coffin burial suggests that the pollen derives from a vegetation covering, body contents, a mat or a floral tribute.

#### *Organic residue within the Food Vessel*

The interior of the Food Vessel contained traces of a crumbly blackish-brown organic encrustation extending between the base and the rim. The material is thought to derive from the original evaporated contents of the vessel, rather than burnt-on material. The radiocarbon determination from the Food Vessel residue suggests that contamination of the sample is a strong possibility. Nonetheless, pollen analysis of the residue was considered worthwhile, as intrinsic pollen assemblages would remain unaffected by carbon exchange of the pollen-supporting matrix with external sources, the exception being if contamination occurred from a pollen-bearing source. However, control sampling from outside the pot and from various levels of the internal fill was designed to detect external sources of pollen contamination. The pollen count and estimated pollen concentration from the sample of organic residue was extremely low, yielding a total of five identifiable pollen grains and 65 *Lycopodium* marker grains. The poor results preclude any meaningful interpretation of the sample.

Conversely, samples of the sandy sediment fill of the vessel, originally intended as a control for the pollen analysis of the organic residue, yielded statistically robust spectra in terms of pollen sum. The assemblage was dominated by dogwood (cf *Cornus*), buttercup (*Ranunculus* undiff), alder (*Alnus glutinosa*), bedstraw (*Rubiaceae*) and hazel/myrtle (*Corylus avellana* type), with lesser amounts of other taxa including grasses (*Poaceae*), bracken (*Pteridium aquilinum*) and plantain (*Plantago* indet). There are similarities between this assemblage and that from the log-coffin floor; the major difference is that in these samples, bedstraw is present and bracken virtually absent. The taphonomy of this pollen assemblage is uncertain. It is possible that it derives from anthropogenic activities relating to the burial. A covering of planks or branches of alder and hazel with the other vegetative elements used as padding (cf Mapleton 1878; Abercromby 1905), or perhaps as a decorative

element, could explain the assemblage. The potential significance of the vessel fill was not apparent at the outset and control samples to assist taphonomic interpretation were not available.

#### *Beaker*

Three samples from the sandy fill of the Beaker from Cist 2 were examined, but only trace elements of pollen were found. Alder pollen dominated all three samples with lower amounts of hazel/myrtle present. No indications of past pot use were apparent from the three samples.

A more detailed account of the results from pollen analyses with accompanying graphs is in the site archive.

### PHOSPHATE ANALYSES

Ciara Clarke & Michael Cressey

Samples for phosphate analysis were taken from sediments within the plank-built coffin and log-coffin stains using a random and grid sample strategy in order to assess the inorganic phosphate component present. The results of the analyses are expressed as P  $\mu\text{g/g}$ . The analytical technique used in this study is an adaptation of the methods devised by Jackson (1958) and Hamond (1983). The results support the suggestion of the former presence of a body in each of the coffins.

#### *Plank-built coffin*

A mean of 3415  $\mu\text{g/g}$  P was calculated from 14 randomly placed samples from the interior of the coffin's rectangular soil stain. The highest value attained was 7028  $\mu\text{g/g}$  which is considered anomalous when compared to a control average of 2613  $\mu\text{g/g}$ . The high P values from within the coffin reflect local increases in P that might possibly be attributed to the position of a body or some other organic material. Although only a limited amount of work was undertaken on the coffin samples the results do confirm anomalous P values within its interior and strongly suggest enrichment either by human remains or some other organic material that left no visible traces in the soil.

#### *Log-coffin*

The acidic nature of the soil has led to the degradation of the human bone, with only the more resilient

TABLE 12  
Radiocarbon determinations

Feature	Sample	Laboratory no	Date BP	Cal BC at 2σ
Pit with cremation inside ring ditch	Pyre debris (oak charcoal)	AA-29062	3845 ± 50	2470–2190 (91.5%) 2170–2140 (3.9%)
Plank-built coffin	Organic residue from Food Vessel	AA-29063	2625 ± 45	900–750 (89.7%) 690–660 (2.7%) 630–590 (2.0%) 580–560 (1.0%)
Log-coffin	Cattle skin from dagger scabbard	AA-29064	3385 ± 45	1870–1840 (2.1%) 1780–1520 (93.3%)
Pit 3	Pyre debris (hazel charcoal)	GU-7590	3360 ± 50	1750–1510 (95.4%)

tooth enamel and fragments of a femur and one other bone surviving. The survival of organic traces of skin and hair surrounding the dagger blade provided a P value of 7676µg/g. The elevated organic content of the log-coffin’s internal fill attained a mean of 2688µg/g (n = 10), in accordance with the presence of human remains.

THE RADIOCARBON DATES

Michael Cressey & Alison Sheridan

Four samples (charcoal from the cremation burial within the ring-ditch and from Pit 3, organic residue from the interior of the Food Vessel, and a fragment of the skin from the dagger scabbard) were submitted to the Scottish Universities Research Reactor Centre (SURRC) for accelerator dating. The dates (Table 12) have been calibrated using OxCal v3.5 (Bronk Ramsey 2000), using atmospheric data from Stuiver et al (1988), and are cited at 2σ; all other dates cited in this report have been calibrated in the same way.

There seems to be no reason to doubt the validity of the charcoal-derived dates; the hazel roundwood from Pit 3 would not have been old, and the oak charcoal used to date the cremation burial from within the ring-ditch derived from a branch, rather than from heartwood. Unless bog oak had been used, there is no reason to assume the use of old wood here. The significance of these results is discussed below.

As mentioned above, the two dates from the coffin graves are suspect. That from the scabbard is a few centuries later than expected, while the Food Vessel organic residue date is over a millennium later than expected. No obvious sources of contamination are evident; the scabbard sample, for example, was kept cool to prevent mould growth.

DISCUSSION AND CONCLUSIONS

Alison Sheridan, Michael Cressey & Graeme Warren

The excavations at Seafield West have revealed evidence for human activity over a considerable time depth and, together with the evidence from Raigmore, c 700m to the west (Simpson 1996), have highlighted the importance of this sand-and-gravel ridge as a locus for Bronze Age funerary activity. The presence of wooden coffins is an extremely rare phenomenon in Scotland, and the Irish connections of their associated artefacts require explanation. These, together with the overall sequence of funerary activities, will be discussed below.

MESOLITHIC ACTIVITY

The Seafield material indicates some activity on a ridge immediately above the main post-glacial transgression cliff on the south shore of the Moray Firth. Unfortunately, dating this phase of activity is very difficult as narrow-blade assemblages are used widely throughout the Mesolithic and are well known in the region. A narrow-blade assemblage including a range of microlith types, blades and small cores was found at Castle St, Inverness, in a hollow in a ravine on the west of Castle Hill (Wordsworth 1985). Two horizons are identified, but are indistinguishable in date and indicate activity at some stage before the post-glacial maximum sea level in the area: 7275 ± 235 BP (6600–5650 cal BC at 2σ,

GU-1376) and  $7800 \pm 85$  BP (7050–6450 cal BC at  $2\sigma$ , GU-1377).

Survey of the Moray coast to the east (Bradley 2000) has demonstrated that Mesolithic scatters have a very strong tendency to be coastal or riverine, and the importance of coastal resources to Mesolithic communities of the region is also indicated by the shell midden at Muirtown, immediately to the east of Inverness (Myers & Gourlay 1991). Charcoal from within the midden dates to  $5365 \pm 65$  BP (4340–4040 cal BC at  $2\sigma$ , GU-1473). Finds of microliths and midden deposits are also noted from Milton of Culloden (Wordsworth 1992) but no details are available. However, the indications are that Mesolithic settlement in this area is very widespread. Stepping away from the immediate region a number of Mesolithic sites in eastern Scotland are located near the coast, often on well-drained ridges above lower-lying land (for example, Wickham-Jones & Dalland 1998; for overall review see Warren 2001) and Seafield also fits into this context. The Mesolithic artefacts from Seafield, then, provide another confirmation of the extensive use of the coast by gatherer-hunter communities in the region, but they do not add much detail to this discussion.

#### THE SEQUENCE OF EARLY BRONZE AGE FUNERARY ACTIVITIES

The paucity of dates, and the unreliability of two key dates, make it impossible to present a definitive account, although it seems clear that the pit cluster cemetery post-dates the ring-ditch cemetery, probably by several centuries. Establishing a sequence of events for the ring-ditch cemetery is problematical, not least because the two wooden coffin graves – which one would expect to be the primary features – are not in the centre of the area enclosed by the ring-ditch. More nearly central is the pit 019, which could conceivably be a truncated inhumation pit grave. Nevertheless, an association between the wooden coffin graves and

the ring-ditch seems likely in view of the evidence from Bowthorpe, Norfolk (Lawson 1986), where a boat-shaped log-coffin was the central, primary grave inside a ring-ditch (and where subsequent graves included plank-built coffins). That the two wooden coffins were not deposited simultaneously is suggested by the fact that they occupy discrete but adjacent pits, so close to each other that they cannot have been dug simultaneously; but whether the ‘dagger grave’ came first, and what interval separated them, cannot be determined. All that can be said is that both are likely to date to between 2200–1950 BC, and that their juxtaposition suggests a significant relationship between their occupants.

The date of  $3845 \pm 50$  BP (2470–2140 cal BC) obtained for the cremation burial within the ring-ditch – if accepted at face value – suggests that this grave is likely to pre-date the wooden coffin graves. Furthermore, if one accepts the admittedly minimal comparative dating evidence relating to the step 5/6 Beaker from Cist 2, this cist could also pre-date the wooden coffin graves and be roughly contemporary with the cremation. This raises the possibility that the coffin graves and ring-ditch were established within a pre-existing, unenclosed cemetery. Unfortunately, there are too many ‘unknowns’ and uncertainties to speculate further.

#### THE WOODEN COFFINS

The presence of not one but two wooden coffins, and the fact that one had been a hollowed-out log in the shape of a boat while the other had been plank-built, is of considerable significance, as prehistoric wooden coffins are extremely rare in Scotland. In reviewing the Scottish evidence, Mowat (1996, 83–107 *passim*, 137 ff) lists five examples of prehistoric log-coffins: one each from Dalrigh near Oban, Argyll & Bute (his no A57), Dumglow, Perth & Kinross (A17) and Williamston, Aberdeenshire (A71); and two from Cairngall, Aberdeenshire (A9). Elgee and Elgee (1949) had



claimed that a grave from Bishopmill, Moray had been a log-coffin, but others (for example, Henshall 1968) have made it clear that it was a stone cist.

Where their lengths have been recorded, these five log-coffins are comparable with the Seafield example (1.8–2.2m compared with 2.0m). None is boat-shaped, although the Dalrigh example was originally described as a ‘canoe’ (Mapleton 1879; RCAHMS 1975, 60, no 98(5)) and may have been adapted from such a use (Mowat 1996, 102). Apart from hazelnuts, shells and charcoal in the Dalrigh coffin, the only grave good recorded is an ‘urn’ from Williamston. A fragment of a sewn birch-bark cover from the Dalrigh coffin has recently been dated to  $3555 \pm 60$  BP (2040–1690 cal BC at  $2\sigma$ , OxA-6813; Sheridan 2002b).

Around 35 other prehistoric log-coffins are known from the rest of Britain (Elgee & Elgee 1949; Ashbee 1960; Dent 1983; Lawson 1986; Powlesland 1986; Smith 1994), with concentrations in north-east England and in and around Wessex (Ashbee 1960, fig 26). A minority of these – most famously the ‘canoe’, coffin and coffin-cover from Loose Howe, Yorkshire (Elgee & Elgee 1949) – is boat-shaped, and the Elgees claimed that at least one of these had originally been a serviceable vessel. However, in discussing the example from Bowthorpe, Norfolk, Heal (1986) pointed out that the presence of bark and sapwood on the Loose Howe ‘canoe’ made it unlikely that it had been serviceable; all three items were more likely to be evocations of boats. This arguably contrasts with the evidence from an Early Bronze Age cemetery on the coast at Barns Farm, Fife, where at least one framed skin coracle appears to have been used as a coffin; its occupants were accompanied by fish bones, and in their lifetime they may well have spent much time fishing (Watkins 1982). Whether or not the boat-shaped log-coffins had been actual boats, the potential symbolic significance of despatching the deceased to the afterlife in a boat-like coffin is obvious.

The British log-coffins seem to have been used over several centuries. The earliest dated examples, from Cartington, Northumberland (associated with a Beaker) and Dysgwlyfa Fawr, Dyfed, are dated to  $3790 \pm 65$  BP (2460–2030 cal BC at  $2\sigma$ , GU-1648) and  $3860 \pm 70$  BP (2500–2130 cal BC at  $2\sigma$ , HAR-2187) respectively while the latest, from Hove, Sussex, dates to  $3189 \pm 46$  BP (1600–1310 cal BC at  $2\sigma$ , BM-682) and is associated with a ‘Wessex 2’, Aldbourne–Edmondsham type grave assemblage (Mowat 1996, 140). In common with many of the south Scandinavian log-coffin burials of the 15th to 13th century BC (Kähler Holst et al 2001), the British examples appear to have been used for high-status burials. Not only would the process of making the coffin have involved considerable effort, but often precious grave goods have been found in them, including items of gold (Stoborough, Dorset), amber and jet (Elgee & Elgee 1949). Daggers and knife-daggers have been found in no fewer than nine instances, and although in most cases the human remains were not sexable, at Gristhorpe, Yorkshire, the dagger was definitely associated with a male (ibid). In general, Bronze Age daggers appear to be a male association (Henshall 1968; Gerloff 1975), and it is therefore quite possible that the occupant of the Seafield log-coffin had been a male.

With the exception of the recently-excavated examples from Bowthorpe, Norfolk (Lawson 1986) and Wether Hill, Northumberland – the latter dated to c 2200–1880 BC and associated with two Beakers (Topping 2001) – Bronze Age composite plank-built coffins are generally less well documented, particularly in Scotland. A possible example is known from Culsalmond, Aberdeenshire, where a ‘decorated urn’ was found in a coffin consisting of two sides, two ends, a bottom and a lid (Ellis 1845). That plank-built coffins may have been a prototype for the grooved and rebated stone cists of Argyll and the Scillies has long been recognized (Ashbee 1960, 91).

#### THE SIGNIFICANCE OF THE IRISH CONNECTIONS

The fact that the bronze dagger in the log-coffin had been made using copper probably from an Irish source, and that the Food Vessel is of a distinctively Irish type not otherwise found in this part of Scotland, requires explanation. The answer may well relate to the fact that, as Northover has pointed out above, Ireland was an early producer and exporter of metal. Among the earliest metal objects in north-east Scotland are thick-butted flat axeheads made of Irish copper, which may have been imported from as early as c 2400/2300 BC (Brindley 1995). And although it may have been metalworkers from across the North Sea, rather than from Ireland, who introduced the practice of tin-bronze manufacture to north-east Scotland around 2200 BC (Cowie 1988, 7–9; Northover 1999; cf Pare 2000 on the dating), nevertheless the importation of Irish copper seems to have continued, as the composition of the Seafield West dagger indicates. One obvious route from Ireland, with a history of Neolithic use, is via the Kilmartin area of Argyll, and up the Great Glen along Loch Ness. The use of the Great Glen route for two-way movement of material is well (if indirectly) illustrated by the ceremonial deposits of Migdale axeheads and Type Milston daggers at Dail na Caraidh, Highland (Barrett & Gourlay 1999). An entrepreneurial role in such a ‘trade’ by the inhabitants of Mid Argyll may explain both the wealth of the funerary monuments in that area – with some cists adorned with carvings of metal flat axeheads (RCAHMS 1988) – and the presence there of Irish-style Food Vessels. A link with Argyll could account for the presence of the Irish Bowl Food Vessel at Seafield West (and perhaps also for the fact that the dagger there is of the same type as the one found at Cleigh: RCAHMS 1975, 53, no 57(4)); and the boat represented or evoked in the Seafield log-coffin is of a type suited to inland, rather than seaborne navigation – in other words, the kind

of craft that could have plied up and down Loch Ness (Mowat 1996). Whether the occupants of the wooden coffins were themselves Irish, or were local people displaying their prestigious exotic possessions, cannot be determined.

#### CONCLUSIONS

The Mesolithic inhabitants of the Seafield West area appear to have formed part of a broader regional pattern of coastal exploitation, while their Bronze Age successors also conformed to a widespread pattern, by siting their burials on a sand-and-gravel ridge (cf, for example, McAdam 1974, Ralston 1996, Simpson 1996).

The evidence from the ring-ditch cemetery indicates that, around the end of the third millennium BC, the inhabitants of Seafield West enjoyed wide-ranging contacts. These contacts allowed some members of the community to employ funerary practices which may, in a local context, have appeared exotic; and to underline their status using grave goods with strong Irish connections.

#### ACKNOWLEDGEMENTS

Michael Cressey would like to thank Mr Gordon Milne of the Inverness Business and Retail Park for funding the excavation and later phases of work at the site; the National Museums of Scotland for their assistance with the post-excavation work; and Dr John Craven of the University of Edinburgh Geology Department for his SEM work on the cattle hair. John Wood and Dorothy Low of the Highland Archaeology Service provided advice during the excavation; Mark Eliot helped with on-site conservation; and Julie Franklin assisted during the excavation. Alison Sheridan thanks Anna Brindley for providing valuable information on Irish Food Vessels, and Dr Brendan O’Connor for his advice. Both authors thank Graham Ritchie and Ian Shepherd for their useful comments on the text.

#### REFERENCES

Abercromby, J 1905 ‘Report on excavations at Fethaland and Trowie Knowe, Shetland; and

- of the exploration of a cairn on Dumglow, one of the Cleish hills, Kinross-shire', *Proc Soc Antiq Scot*, 39 (1904–5), 171–84.
- Appleyard, H M 1978 *Guide to the Identification of Animal Fibres*. Leeds.
- Ashbee, P 1960 *The Bronze Age Round Barrow in Britain*. London.
- Baker, L, Sheridan, J A & Cowie, T G 2003 'An Early Bronze Age "dagger grave" from Rameldry Farm, near Kingskettle, Fife', *Proc Soc Antiq Scot*, 133, 85–123.
- Banks, I 1993 'West Seafield Farm (Inverness and Bona parish): Cropmarks', *Discovery Excav Scot* 1993, 44.
- Barclay, G J & Russell-White, C J 1993 'Excavations in the ceremonial complex of the fourth to second millennium BC at Balfarg/Balbirnie, Glenrothes, Fife', *Proc Soc Antiq Scot*, 123, 43–210.
- Barnatt, J 1994 'Excavations of a Bronze Age unenclosed cemetery, cairns, and field boundaries at Eagleston Flat, Curbar, Derbyshire 1984, 1989–90', *Proc Prehist Soc*, 60, 287–370.
- Barrett, J C & Gourlay, R B 1999 'An early metal assemblage from Dail na Caraidh, Inverness-shire and its context', *Proc Soc Antiq Scot*, 129, 161–87.
- Bass, W M 1987 *Human Osteology*. Missouri.
- Beek, G C van 1983 *Dental Morphology: an Illustrated Guide*. Bristol, London & Boston.
- Bennett, K D 1994 *Annotated Catalogue of Pollen and Pteridophyte Spore Types of the British Isles*. Cambridge. (<http://www.kv.geo.uu.se/pc-intro.html>)
- Bennett, K D, Whittington, G & Edwards, K J 1994 'Recent nomenclatural changes and pollen morphology in the British Isles', *Quaternary Newsletter*, 73, 1–6.
- Boyd, W E 1988 'Cereals in Scottish Antiquity', *Circaea*, 5.2, 101–10.
- Bradley, R J 2000 *The Good Stones: a New Investigation of the Clava Cairns*. Edinburgh (=Soc Antiq Scot monogr, 17).
- Brindley, A L 1995 'Radiocarbon, chronology and the Bronze Age', in Waddell, J & Twohig, E S (eds) *Ireland in the Bronze Age*, 4–13. Dublin.
- Brindley, A L 2001 'Tomorrow is another day: some radiocarbon dates for Irish bronze artefacts', in Metz, W H, van Beek, B L & Steegstra, H (eds) *Patina: Essays Presented to Jay Jordan Butler on the Occasion of his 80th Birthday*, 145–60. Groningen.
- Bronk Ramsey, C 2000 *OxCal Version 3.5*. Oxford.
- Christison, D & Anderson, J 1905 'Report on the Society's excavations of forts on the Poltalloch Estate, Argyll', *Proc Soc Antiq Scot*, 39 (1904–5), 259–322.
- Clapham, A R, Tutin, T G & Moore, D M 1989 *Flora of the British Isles*, 3rd edn. Cambridge.
- Clarke, C M 1994 *Fungal Spores as Palaeoenvironmental Indicators of Anthropogenic Activity*. PhD thesis, Univ Edinburgh.
- Clarke, C M 1999 'Palynological investigations of a Bronze Age cist burial from Whitsome, Scottish Borders, Scotland', *J Archaeol Sci*, 26, 553–60.
- Clarke, D L 1970 *Beaker Pottery of Great Britain and Ireland*. Cambridge.
- Close-Brooks, J 1985 'Appendix 1: the prehistoric finds', in Stewart, M E C, 'The excavation of a henge, stone circles and metal working area at Moncreiffe, Perthshire', *Proc Soc Antiq Scot*, 115, 142–3.
- Cowie, T G 1988 *Magic Metal: Early Metalworkers in the North-East*. Aberdeen.
- Cressey, M 1996 *Archaeological Site Evaluation at Seafield West, Inverness, Highland Region. Centre for Field Archaeology, University of Edinburgh. Data Structure Report No 273*. Edinburgh.
- Cushing, E J 1967 'Evidence for differential pollen preservation in Late Quaternary sediments in Minnesota', *Rev Palaeobotany Palynology*, 4, 87–101.
- Dent, J 1983 'A summary of the excavations carried out in Garton Slack and Wetwang Slack 1964–1980', *East Riding Archaeologist*, 7, 1–14.
- Dickson, C A 1997 'Plant remains', in Mercer, R J & Midgley, M S, 'The early Bronze Age cairn at Sketewan, Balnaguard, Perth & Kinross', *Proc Soc Antiq Scot*, 127, 318–22.
- Dickson, J H 1978 'Bronze Age mead', *Antiquity*, 42, 108–13.
- Dimbleby, G 1978 *Plants in Archaeology*. London.
- Edmonds, M 1995 *Stone Tools and Society: Working Stone in Neolithic and Bronze Age Britain*. London.
- Edmonds, M & Thomas, J 1987 'The Archers: an everyday story of country folk', in Brown, A G & Edmonds, M (eds) *Lithic Analysis and Later*

- British Prehistory: Some Problems and Approaches*, 187–99. Oxford.
- Elgee, H W & Elgee, F 1949 'An Early Bronze Age burial in a boat-shaped wooden coffin from north-east Yorkshire', *Proc Prehist Soc*, 15, 87–106.
- Ellis, F 1845 'Culsamond Parish', *New Statistical Account of Scotland*, 12, 732–33.
- Gejvall, N G 1981 'Determination of burnt bones from prehistoric graves', *OSSA Letters*, 2, 1–13.
- Gerloff, S 1975 *The Early Bronze Age Daggers in Great Britain*. Munich.
- Gerloff, S 1993 'Zu Fragen mittelmeerländischer Kontakte und absoluter Chronologie der Frühbronzezeit in Mittel- und Westeuropa', *Prähistorische Zeitschrift*, 68.1, 58–102.
- Gray, H 1977 *Anatomy*. New York.
- Grime, J P, Hodgson J G & Hunt R 1988 *Comparative Plant Ecology: a Functional Approach to Common British Species*. London.
- Grinsell, L V 1959 *Dorset Barrows*. Dorchester.
- Hamond, F W 1983 'Phosphate analyses of archaeological sediments', in Reeves-Smyth, T & Hamond, F W, *Landscape Archaeology in Ireland*, 47–80. Oxford.
- Heal, V 1986 'Comment on the form of the central grave coffin', in Lawson, A J, *Barrow Excavations in Norfolk, 1950–82*, 45–7. Dereham.
- Henshall, A S 1964 'A dagger-grave and other cist burials at Ashgrove, Methilhill, Fife', *Proc Soc Antiq Scot*, 97 (1963–4), 166–79.
- Henshall, A S 1968 'Scottish dagger graves', in Coles, J M & Simpson, D D A (eds) *Studies in Ancient Europe*, 173–95. Leicester.
- Jackson, M L 1958 *Soil Chemical Analyses*. London.
- Jervise, A 1867 'Account of the discovery of a circular group of cinerary urns and human bones at Westwood, near Newport, on the Tay', *Proc Soc Antiq Scot*, 6 (1866–7), 388–94.
- Jones, M 1991 'Sampling in palaeoethnobotany', in Zeist, W van, Wasylkova, K & Behre, K E (eds) *Progress in Old World Palaeoethnobotany*, 53–62. Rotterdam.
- Kähler Holst, M, Breuning-Madsen, H & Rasmussen, M 2001 'The south Scandinavian barrows with well-preserved oak-log coffins', *Antiquity*, 75, 126–36.
- Kenward, H K, Hall, A R & Jones, A K G 1980 'A tested set of techniques for the extraction of plant and animal macrofossils from waterlogged archaeological deposits', *Science Archaeol*, 22, 3–15.
- Kinnes, I A, Gibson, A, Ambers, J, Bowman, S, Leese, M & Boast, R 1991 'Radiocarbon dating and British Beakers: the British Museum programme', *Scott Archaeol Rev*, 8, 35–68.
- Lanting, J N & Brindley, A L 1998 'Dating cremated bones: the dawn of a new era', *J Irish Archaeol*, 9, 1–8.
- Lanting, J N & Waals, J D van der 1972 'British Beakers as seen from the Continent: a review article', *Helinium*, 12, 20–46.
- Lawson, A 1986 'The excavation of a ring-ditch at Bowthorpe, Norwich, 1979', in Lawson, A J, *Barrow Excavations in Norfolk, 1950–82*, 20–49. Dereham.
- Longworth, I H 1984 *Collared Urns of the Bronze Age in Great Britain and Ireland*. Cambridge.
- Maher, L J 1981 'Statistics for microfossil concentration measurements employing samples spiked with marker grains', *Rev Palaeobotany Palynology*, 32, 153–91.
- Mapleton, R J 1879 'Notice of the discovery of an old canoe in a peat-bog at Oban', *Proc Soc Antiq Scot*, 12 (1878–9), 336–8.
- Marriott, J W 1968 'A Bronze Age burial site at Kinneil Mill, Stirling', *Proc Soc Antiq Scot*, 100 (1967–8), 86–99.
- Mays, S & Steele, J 1996 'A mutilated human skull from Roman St Albans, Hertfordshire, England', *Antiquity*, 70, 155–61.
- McAdam, E 1974 *Some Aspects of Early Bronze Age Short Cists in Scotland*. MA diss, Univ Edinburgh.
- McKinley, J I 1989 'Cremations: expectations, methodologies and realities', in Roberts, C A, Lee, F & Bintliff, J (eds) *Burial Archaeology: Current Research, Methods and Developments*, 65–76. Oxford.
- McKinley, J I 1993 'Bone fragment size and weights of bone from modern British cremations and its implications for the interpretation of archaeological cremations', *Internat J Osteoarchaeology*, 3, 283–7.
- McKinley, J I 1994a *The Anglo-Saxon cemetery at Spong Hill, North Elmham, Part VIII: The Cremations*. Norwich (= East Anglian Archaeol monogr, 69).
- McKinley, J I 1994b 'Bone fragment size in British cremation burials and its implications for pyre

- technology and ritual', *J Archaeol Sci*, 21, 339–42.
- McKinley, J I 1997a 'The cremated human bone from burial and cremation-related contexts', in Fitzpatrick, A P, *Archaeological Excavations on the Route of the A27 Westhampnett Bypass, West Sussex, 1992. Volume 2: the Cemeteries*, 55–72, 244–52. Salisbury.
- McKinley, J I 1997b 'Bronze Age "barrows" and the funerary rites and rituals of cremation', *Proc Prehist Soc*, 63, 129–45.
- McMinn, R M H & Hutchings, R T 1985 *A Colour Atlas of Human Anatomy*. London.
- Moore, P D, Webb, J A & Collinson, M E 1991 *Pollen Analysis*. Oxford.
- Mowat, R 1996 *The Log-Boats of Scotland*. Oxford.
- Myers, A M & Gourlay, R B 1991 'Muirtown, Inverness: preliminary investigation of a shell midden', *Proc Soc Antiq Scot*, 121, 17–25.
- Needham, S P 1998 'Radley and the development of early metalwork in Britain', in Barclay, A & Halpin, C, *Excavations at Barrow Hills, Radley, Oxfordshire. Volume I: The Neolithic and Bronze Age Monument Complex*, 186–92. Oxford.
- Northover, J P 1980 'Analyses of Welsh Bronze Age metalwork', Appendix in Savory, H N, *A Guide Catalogue to the Bronze Age Collections, Cardiff National Museums, Wales*. Cardiff.
- Northover, J P 1999 'The earliest metalworking in southern Britain', in Hauptmann, A, Pernicka, E, Rehren, T & Yalçın, Ü (eds) *The Beginnings of Metallurgy: Proceedings of the International Conference, 'The Beginnings of Metallurgy', Bochum, 1995*, 211–26. Bochum.
- Northover, J P 2003 'The dagger: metallurgical analysis', in Baker, L, Sheridan, J A & Cowie, T G, 98–9.
- Northover, J P forthcoming 'Analyses of the Early Bronze Age metalwork from Gravelly Guy', in Allen, B, Healy, F & Lambrick, G, *Gravelly Guy: the Development of a Prehistoric and Romano-British Landscape*. Oxford.
- Northover, J P, O'Brien, W & Stos, S 2001 'Lead isotopes and metal circulation in Beaker/Early Bronze Age Ireland', *J Irish Archaeol*, 10, 25–46.
- O'Brien, W 1999 *Sacred Ground: Megalithic Tombs in Coastal South-West Ireland*. Galway.
- O'Brien, W, Northover, J P & Cameron, C 1990. 'An Early Bronze Age metal hoard from a wedge tomb at Toormore, Co Cork', *J Irish Archaeol*, 5 (1989–90), 9–17.
- Olivier, A C H 1987 'Excavation of a Bronze Age funerary cairn at Manor Farm, near Borwick, North Lancashire', *Proc Prehist Soc*, 53, 129–86.
- Ó Riordáin, A B & Waddell, J 1993 *The Funerary Bowls and Vases of the Irish Bronze Age*. Galway.
- Pare, C F E 2000 'Bronze and the Bronze Age', in Pare, C F E (ed) *Metals Make the World Go Round*, 1–30. Oxford.
- Piggott, S 1958 'Segmented bone beads and toggles in the British Early and Middle Bronze Age', *Proc Prehist Soc*, 24, 227–9.
- Powlesland, D 1986 'Excavations at Heslerton, North Yorkshire, 1978–82', *Archaeol J*, 143, 53–173.
- Ralston, I B M 1996 'Four short cists from north-east Scotland and Easter Ross', *Proc Soc Antiq Scot*, 126, 121–55.
- RCAHMS 1975 *Argyll: An Inventory of the Ancient Monuments. Volume 2: Lorn*. Edinburgh.
- RCAHMS 1988 *Argyll: An Inventory of the Monuments. Volume 6: Mid Argyll and Cowal, Prehistoric and Early Historic Monuments*. Edinburgh.
- Robinson 1988 *Flora Europaea*. Edinburgh. (<http://www.rbge.org.uk/forms/fe.html>)
- Rogers, J & Waldron, T 1995 *A Field Guide to Joint Disease in Archaeology*. Chichester.
- Ryder, M L 1964a 'Report on hair and skin remains from Ashgrove Farm, Methil, Fife, and other Bronze Age sites', in Henshall, A S, 'A dagger-grave and other cist burials at Ashgrove, Methilhill, Fife', *Proc Soc Antiq Scot*, 97 (1963–4), 174–6.
- Ryder, M L 1964b 'Report on the skin from Pyotdykes', in Coles, J M, Coutts H & Ryder M L, 'A Late Bronze Age find from Pyotdykes, Angus, Scotland, with associated gold, cloth, leather and wood remains', *Proc Prehist Soc*, 30, 193–7.
- Ryder, M L forthcoming 'Examination of the fibres', in Sheridan, J A, Cunningham, C & Ryder, M L, 'The Sheshader "Thing": an organic peatbog find of Bronze Age date from Sheshader, Isle of Lewis'.
- Schweingruber, F H 1990 *Microscopic Wood Anatomy*. 3rd edn. Berne & Stuttgart.

- Shepherd, I A G 1986. *Powerful Pots: Beakers in North-East Prehistory*. Aberdeen.
- Sheridan, J A 2001 'The National Museums of Scotland Dating Cremated Bones Project', *Discovery Excav Scot*, NS 2, 129.
- Sheridan, J A 2002a 'The National Museums of Scotland dating programmes: results obtained during 2001/2', *Discovery Excav Scot*, NS 3, 154–5.
- Sheridan, J A 2002b 'National Museums of Scotland dating programme: 1994–98', in Bronk Ramsey, C, Higham, T F G, Owen, D C, Pike, A W G & Hedges, R E M, 'Radiocarbon dates from the Oxford AMS system: *Archaeometry* Datelist 31', *Archaeometry*, 44 (3, Suppl 1), 55–61.
- Sheridan, J A, Hunter, F J & Saville, A 1995 'Organic artefacts from the collection of the National Museums of Scotland', in Hedges, R E M, Housely, R A, Bronk Ramsey, C & van Klinken, G J, 'Radiocarbon dates from the AMS system: *Archaeometry* datelist 20', *Archaeometry*, 37.2.
- Simpson, D D A 1968 'Food Vessels: associations and chronology', in Coles, J M & Simpson, D D A (eds) *Studies in Ancient Europe*, 197–211. Leicester.
- Simpson, D D A 1996 Excavation of a kerbed funerary monument at Stoneyfield, Raigmore, Inverness, Highland, 1972–3, *Proc Soc Antiq Scot*, 126, 53–86.
- Smith, M J B 1994 *The Excavated Bronze Age Barrows of North East Yorkshire*. Durham.
- Stace, C 1991 *New Flora of the British Isles*. Cambridge.
- Stevenson, S 1995 'The excavation of a kerbed cairn at Beech Hill House, Coupar Angus, Perthshire', *Proc Soc Antiq Scot*, 125, 197–235.
- Stuiver, M, Reimer, P J, Bard, E, Beck, J W, Burr, G S, Hughen, K A, Kromer, B, McCormac, G, van der Plicht, J & Spurk, M 1998 'INTCAL98 Radiocarbon Age Calibration, 24000–0 cal BP', *Radiocarbon*, 40.3, 1041–83.
- Tipping, R 1994a "'Ritual" floral tributes in the Scottish Bronze Age – palynological evidence', *J Archaeol Sci*, 21, 133–9.
- Tipping, R 1994b 'The form and fate of Scotland's woodland', *Proc Soc Antiq Scot*, 124, 1–54.
- Topping, P 2001 'A Beaker/Food Vessel assemblage from the Northumberland Cheviots', *Antiquity*, 75, 263–4.
- Walker, I C 1966 'The Counties of Nairnshire, Moray and Banffshire in the Bronze Age', *Proc Soc Antiq Scot*, 98 (1964–6), 76–125.
- Warren, G M 2001 *Towards a Social Archaeology of the Mesolithic in Eastern Scotland: Landscapes, Contexts and Experience*. PhD thesis, Univ Edinburgh.
- Watkins, T 1982 'The excavation of an Early Bronze Age cemetery at Barns Farm, Dalgety, Fife', *Proc Soc Antiq Scot*, 112, 48–141.
- Webb, P A O & Suchey, J M 1985 'Epiphyseal union of the anterior iliac crest and medial clavicle in a modern multiracial sample of American males and females', *American J Phys Anthropol*, 68, 457–66.
- Whittington, G 1993 'Palynological investigations at two Bronze Age burial sites in Fife', *Proc Soc Antiq Scot*, 123, 211–3.
- Whittington, G 1997 'The environment of Upper Kenly', 'The environment' & 'The environment', in Proudfoot, E V W, 'Short-cist burials from Fife. Upper Kenly Farm, Belliston Farm and Dalgety Bay', *Tayside Fife Archaeol J*, 3, 4–5, 8–9, 17–18.
- Wickham-Jones, C R & Dalland, M 1998 'A small Mesolithic site at Fife Ness, Fife, Scotland', *Internet Archaeol*, 5 ([http://intarch.ac.uk/journal/issue5/wickham\\_index.html](http://intarch.ac.uk/journal/issue5/wickham_index.html)).
- Wordsworth, J 1985 'The excavation of a Mesolithic horizon at 13–24 Castle Street, Inverness', *Proc Soc Antiq Scot*, 115, 89–103.
- Wordsworth, J 1992 'Milton of Culloden', *Discovery Excav Scot* 1992, 42.

*This paper is published with the aid of a grant from Inverness Retail Park Ltd*