

## I.

### THE CHAMBER TOMB OF UNIVAL, NORTH UIST.

BY SIR LINDSAY SCOTT, F.S.A., F.S.A.Scot.

The long delay in the publication of this excavation calls for an explanation. The work was begun in 1935 with the consent of the then trustees of the estate,<sup>1</sup> and a brief preliminary report, indicating the importance of the pottery finds which had been made, appeared in December of that year.<sup>2</sup> Thereafter the trustees were moved to withdraw their consent and, as time passed without prospect of the completion of the work, a fuller note was published of the most interesting of the vessels found.<sup>3</sup> It was not till 1939 that the late Mr A. J. H. Edwards, who had then succeeded to the Directorship of the National Museum, and to whom I am much indebted, was able to take action to get consent restored, and the work was completed in the summer of that year. The events of the succeeding years precluded any work on archæology, and the report which is now submitted must, it is feared, suffer from the effect of the vicissitudes to which it has been subject.

#### *The Site.*

Unival is an isolated hill rising to a height of 450 feet out of the central plain of North Uist. From the western foot of the hill the land slopes gently to a sandy shore which, having regard to the then higher level of the land,<sup>4</sup> must have been more than three miles distant from the tomb and beyond the now half-tide islands of Baleshare and Kirkibost. The hill, composed of gneiss which outcrops freely, is now covered with peat, as is most of the land between it and the present shore; no peat underlies the tomb, and none underlies the chamber tomb which lies on the slope of Cletraval, four miles to the north-west,<sup>5</sup> and it may be assumed that, when the tombs were built, the land between the hills and the sea was largely peat-free. There must also have been considerable tree growth, since Neolithic levels produced willow, hazel, oak, pine, and possibly birch charcoals, while Cletraval produced at these levels birch charcoal, and Eilean an Tighe, a Neolithic site by a loch in the north of the island, birch, hazel and some willow. By Iron Age times peat had replaced wood as fuel, and the only timber found at Unival was willow, and at Cletraval willow and Scots fir.

The tomb lies on the south-western shoulder of the hill on an uneven

<sup>1</sup> I should like to acknowledge the kindness of Captain McErlich of Lochmaddy, then factor to the estate, who throughout gave all assistance in his power. The estate has subsequently been bought by the Duke of Hamilton.

<sup>2</sup> *P.P.S.*, 1935, 142.

<sup>3</sup> *P.S.A.S.*, lxi, 480 ff.

VOL. LXXXII.

<sup>4</sup> *Ibid.*, 1938, 336-7.

<sup>5</sup> *Ibid.*, 1948, 70, 71.

terrace just above the 250-foot contour. South-west of the tomb, and 23 feet beyond the nearest point of the peristalith, is a large and conspicuous standing-stone 5 feet in width and standing 10 feet above the original ground-level with its face towards the centre of the mound.<sup>1</sup> This stone is believed to form an element in the tomb structure. The stones of the cairn had been used in the Iron Age to build a small house and, probably, outbuildings, but apart from these the only visible structures in the neighbourhood of the tomb are the mounds of a hamlet at the foot of the hill a quarter of a mile to the south-east which, to judge from stray sherds, cannot be earlier than the Iron Age. It should be noted, though without suggesting that it need be other than a coincidence, that from the standing-stone and from the centre of the mound, but not from the mound's north-eastern edge, the conspicuous chamber tombs of Cletraval and Barpa Langass are both visible simultaneously on their respective hills.

The successive occupations of the site were these. The first use was as a tomb, a number of burials having been made accompanied with Neolithic pottery, and other burials with Early Bronze Age pottery.<sup>2</sup> The next occupation was in the Iron Age, when a small house and storeroom were built in the north-east corner of the cairn; the disturbed areas on the west side of the cairn, which were not excavated, probably contain the remains of slighter outbuildings belonging to this house. In the building of this house a number of façade and peristalith orthostats were removed and broken up or otherwise reused; while the tomb chamber was unroofed and taken into use as a cooking-pit. After an interval, later Iron Age people made casual use of the site, probably for summer shielings, and the tomb chamber was again employed as a cooking-pit. There were no indications of Dark Age or later use, save those casual rearrangements of stones to provide temporary shelters which are made by herdsmen of any period. There was nothing in the vicinity to show that stone had ever been removed from the site, and it is most unlikely that this was at any time attempted. The structures found must therefore be interpreted in the light of the material on the site without resort to the convenient hypothesis that material has been removed from it.

#### *The Iron Age House.*

The house extended from the north side of the tomb chamber to the northern edge of the cairn, where its construction had involved the destruction of a section of peristalith (fig. 1).<sup>\*</sup> It consisted of two more or less

<sup>1</sup> The stone circle reported in *R.C.A.M., The Outer Hebrides, Skye and the Small Isles*, No. 228, is the peristalith of the tomb.

<sup>2</sup> The terms "Neolithic pottery" and "Early Bronze Age pottery" are used purely conventionally to describe pottery types, and without any implication that these types belonged to "Neolithic" or "Early Bronze" ages.

\* Fig. 1 appears opposite p. 48.

rectangular rooms opening out of each other, and had been hollowed out of the cairn and founded on a foot or more of cairn material. The inner facing walls, which revetted the cairn material behind them, were of dry masonry of poor quality and stood to an average height of 2 feet 6 inches, their original height having probably been little greater. Two entrance passages passed through the thickness of the walls and opened into the living-room on opposite sides of the fire, an arrangement found in recent times in beehive houses and permitting of the weather door being kept closed and the lee door open. The western entrance passage had at its inner end a sill stone built into the wall at either side, and at its outer end a displaced peristalith orthostat had served as a jamb and outer facing wall. Neither passage was wide enough to admit cattle, and it may be presumed provisionally, in the absence of excavation, that the slighter structures within the disturbed areas on the west side of the cairn had provided shelter for animals.

The living-room (Pl. II, 1) was roughly rectangular, 8 feet by 6 feet 6 inches, with its north wall bowed outwards, leaving room to pass round the hearth. At its south-east corner was an indeterminate recess, into which the south wall had in part slipped; at its south-west corner was an aumbry, 9 inches high, 12 inches wide and 18 inches deep, set 6 inches above the base of the wall. The floor, which was at the level of the bottom of the facing walls, was of compacted earth, red-brown in colour and containing patches of thin pan; it was nowhere paved. The hearth was indicated by a pile of ochreous peat, some 2 feet in diameter and containing indeterminate bone fragments, set upon boulders and without a kerb. On and in the floor, but not in the cairn boulders below it, was a scatter of sherds, animal bones, and winkle- and cockle-shells. On the floor beside the aumbry there was a pile some 15 inches in diameter of red-brown clay. In the light of the use of clay for luting stonework observed in other Iron Age houses, this clay may have been intended for lining the aumbry for use as a place of storage.

From the south-east corner of the living-room a passage 3 feet long and 2 feet broad led into the second room. Many sherds and some bones were found on the floor of this passage, and a quantity of slabs may indicate that it was roofed with a corbelled barrel vault. The inner room was roughly rectangular, 9 feet by 5 feet 6 inches, but its north wall, like that of the living-room, was bowed outwards. The southern part of the room was paved with slabs set in thin earth upon cairn boulders at a level of 1 foot above the rest of the floor. North of this dais, and near the centre of the room, was a pile of ochreous peat-ash some 3 feet 6 inches in diameter and 5 to 6 inches thick at the centre, set upon cairn boulders and having no kerb. The dais slightly overlapped the area of peat-ash, but appeared none the less to be an original feature, the intrusion of the ash beneath it

being due to the remaking from time to time of its weak and ill-supported edge. No bones, sherds or other artifacts were found among the peat-ash, or elsewhere in the room, and it is clear that the fire was not used for cooking and that the pile was not a dump of ashes from a cooking-fire. The arrangement of hearth and dais was similar to that currently adopted in the Faeroes in rooms specially built for drying grain,<sup>1</sup> and, although no grain had survived or was identified, this room probably served a similar purpose. Stains

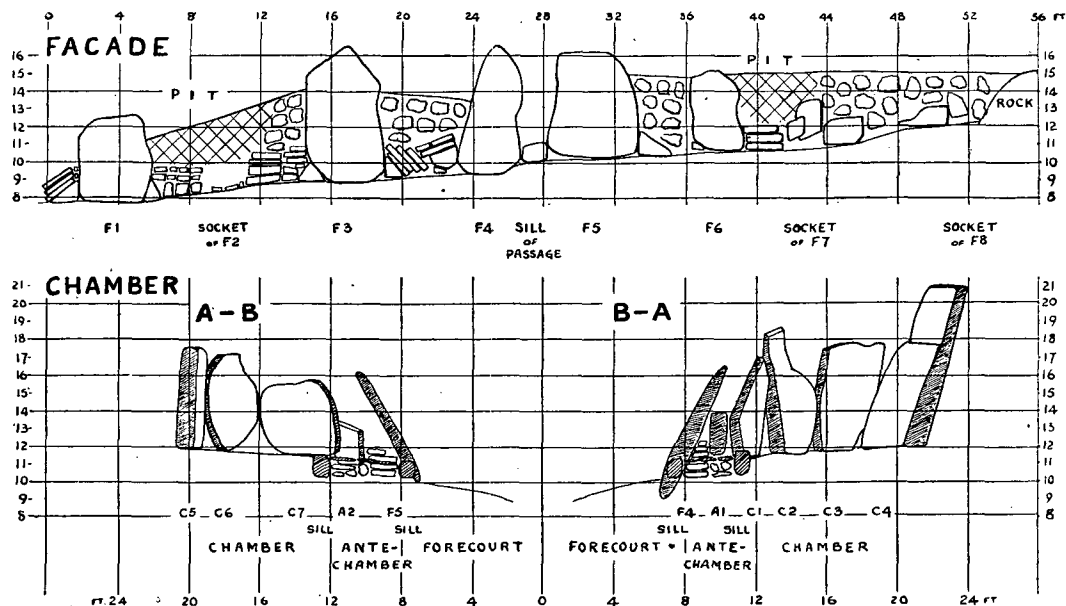

Fig. 2. Façade Elevation, and Sections of Chamber.

of charcoal in the floors of both rooms are likely to represent roofing materials, and the roofs of both may be assumed to have been timber-framed and covered with thatch or turf.

Two deep pits had been left in the cairn when the orthostats F2 and F7 were removed: their size and position are shown in fig. 2. These had been used as rubbish pits and had subsequently become filled by the growth of peat. The F2 pit contained Iron Age sherds and fire-reddened clay; the F6-7 pit contained Iron Age sherds, bone fragments, and a quantity of winkle- and cockle-shells, which were clearly refuse from the house.<sup>2</sup> The

<sup>1</sup> K. Williamson, *The Atlantic Islands*, 206 ff. Half of the room is occupied by a low rack, on which the grain is spread on a layer of straw, and a peat fire is lit contiguous with this in the middle of the room, which is kept closed to keep the heat in. The other half of the room serves as a threshing floor, and the whole serves at other times for storage. Mr Williamson's book contains many valuable data on material culture and on practices which have died out in the Shetlands, Orkneys and Hebrides without more than casual record, but were once common to all the islands.

<sup>2</sup> For the classification of finds see Appendix II.

unroofed tomb chamber had been used as a cooking-pit; a heavily burned layer 2 to 3 inches thick (shown by the broad black bands in the profiles in fig. 5) had been laid down over the funerary deposits and was composed of earth, peat-ash, some charcoal, and numerous Iron Age sherds. At a subsequent stage the surviving long roofing slab had fallen to its present position as shown in fig. 5, and was embedded in the burnt layer; a quantity of small slabs had also fallen and earth had accumulated. This upper stratum of fallen and accumulated material also contained Iron Age sherds, and within it, in the part of the chamber east of the roofing slab, at 14 feet to 14 feet 3 inches above datum, there was a further compacted burnt layer containing red and yellow peat-ash, charcoal and sherds. Scattered Iron Age sherds were also found in the turf throughout the areas adjacent to the central part of the tomb façade, and also in the vicinity of the section of the peristalith excavated at the south-west corner of the cairn. A flint with fairly steep flaking along one edge came from the upper Iron Age level in the chamber, and two thermally fractured pieces with cortex showing them to be derived from beach pebbles from other Iron Age contexts.

*The Iron Age Pottery.*—The rims and decorated sherds are shown in fig. 3, and the pottery has been briefly discussed in a study of the sequence of Iron Age wares within the area occupied by the aisled round-house culture.<sup>1</sup> The quantity is small and the distinctive sherds few. The ware from the house is comparable in shape with that of the second stage of Jarlshof Village, while the finger-nail decoration on the rims corresponds with the finger-tip decoration there. Horizontal furrows below the rim occur at Scarborough,<sup>2</sup> and are characteristic of what is still regarded as an early stage at All Cannings Cross, but they may be centuries later in the north and indeed occur in a Class II broch in Orkney which can hardly have been built much before A.D. 100.<sup>3</sup> The second stage at Jarlshof—or at least the introduction of the round-houses which belong to that stage—has been dated to the first century A.D. in the study of the aisled round-house culture mentioned above and, making all allowance for the extreme remoteness of the Shetlands, the Unival house cannot well be dated earlier than the first century B.C.

The pit contiguous with the house, and the lower Iron Age stratum in the tomb chamber (F6-7 and A7 in fig. 3), each produced one sherd of more or less distinctive shape, and both are consistent with belonging to the ware used in the house. In contrast with these the pottery from the upper Iron Age stratum in the tomb chamber (A6 in fig. 3) includes two sherds belonging to the aisled round-house culture: a sharply everted rim and a much abraded example of the undulating line pattern executed in relief technique. One scrap from pit F2, and possibly a second, belong to the

<sup>1</sup> *P.P.S.*, 1948, 58.

<sup>3</sup> Midhowe, *P.S.A.S.*, lxxviii. 505, fig. 50, 10.

<sup>2</sup> *Arch.*, lxxvi. pl. xxi, 6, and fig. 55.

same pot as the latter, and three rim sherds from the vicinity of the southern façade (F3-4 and F4-5 in fig. 3) are perhaps more likely to belong to this

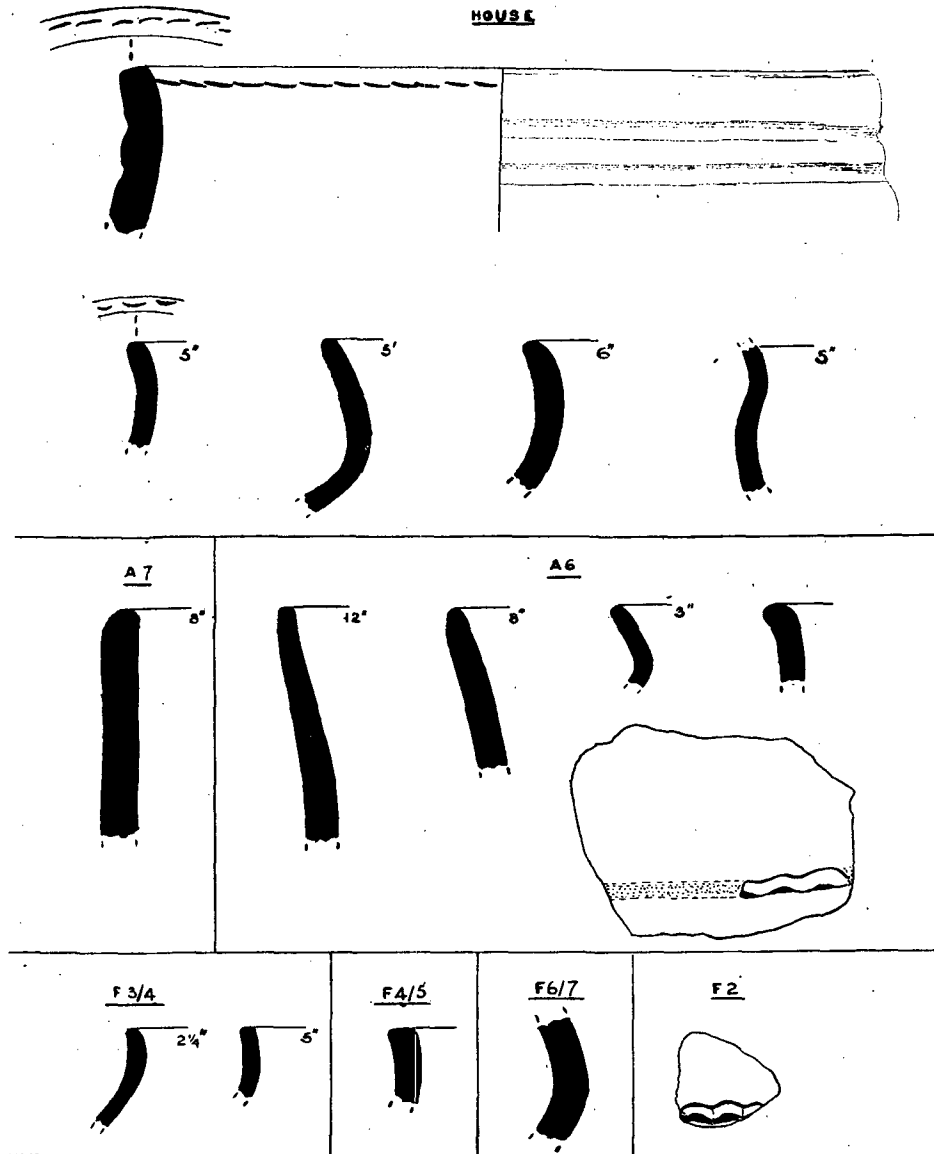

Fig. 3. Iron Age Pottery (†).

occupation than to the earlier one. The second Iron Age occupation of the house accordingly fell within the period of the aisled round-house culture,

though perhaps late in that period, and within the early centuries of the present era.

*Character of the Iron Age Occupations.*—In a house with a paved floor broken pottery is almost entirely removed by sweeping, but this house was unpaved, and the paucity of the pottery finds from its floor and the near-by rubbish pit argues a low level of culture. The slightness of the building itself argues a short life. The main occupation may be assumed to have been cattle farming, and the only identifiable bones were a lower molar of a small ox from the house and two premaxillæ of a small ox from the neighbouring pit; sheep farming was not evidenced either by bones or by textile working tools.<sup>1</sup> Nor were there fish-bones or fishing equipment, though a moderate quantity of shells show occasional visits to the fairly distant shore to dig cockles and gather winkles. Agriculture has been inferred from the arrangement of the storeroom for grain-drying, but at the altitude of the site it must have been secondary to cattle farming. The house may therefore be concluded to have been that of a neatherd living at a low level of culture and probably a little prior to the arrival of the aisled round-house culture in the later first century B.C., though the survival of a primitive settlement such as this into the period of that advanced culture is not to be excluded.

The second Iron Age use of the site fell within the period of that culture. As no structural remains were identified, the site may merely have been used as a place for temporary shielings occupied for the summer pasturing on the hill of animals belonging to the farms on the fertile machair land along the shore.

#### *The Structure of the Tomb.*

The chamber lies within a wedge-shaped tomb enclosure, which, however, does not depart very widely from a square (fig. 1 and Pl. I). The façade, which forms the eastern side of this enclosure, is not quite straight but bowed gently outward in the middle. A portal in the centre of the façade opens into a small antechamber, and this in turn into the chamber. The chamber, antechamber and façade are not co-axial the one with the other, but, for simplicity of description, the axis of each will be conventionally taken as east-west.

The portal is composed of two orthostats divided by a sill, the one 8 feet in height and standing 5 feet 6 inches above the sill, the other shorter and standing slightly lower (fig. 2 and Pl. II, 2). The antechamber is walled on each side by a small orthostat supplemented by well-built dry masonry. A second sill divides it from the chamber, which is egg-shaped, with diameters of 7 and 6 feet. This is walled with large orthostats set contiguously, their

<sup>1</sup> I am greatly indebted to Dr F. C. Fraser of the British Museum (Natural History) for examining the animal bones from the Iron Age levels.

feet resting on, but not in, the floor; they are maintained in positions nearly, but not quite, vertical by the pressure of the cairn behind them and by their lateral pressure the one upon the other. Small gaps between their feet had been filled with rough dry walling, now collapsed. The western orthostat

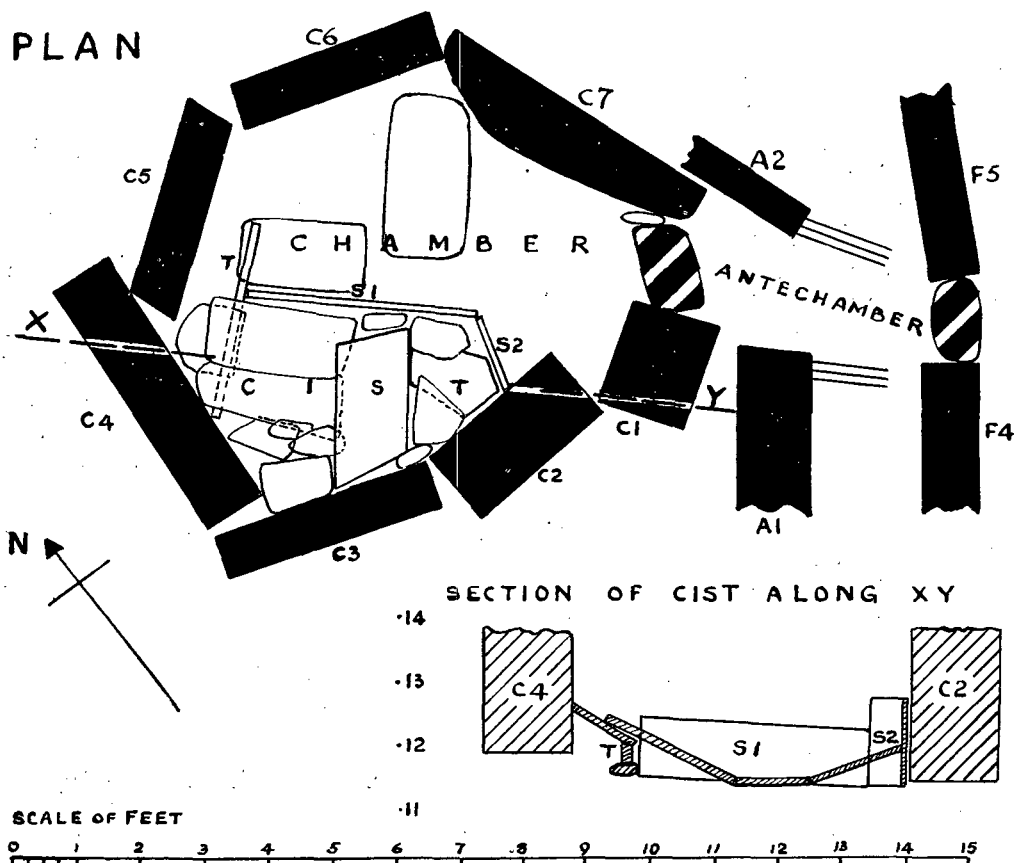

Fig. 4. Plan of Chamber, and Section of Cist.

C4 has a broad ledge on its inner face at 6 feet above the floor and rises 3 feet above that. In the south-west corner of the chamber is a burial cist with steeply sloping head and foot which is very carefully built with thin slabs (plan and section in fig. 4 and Pl. III, 1).

Nothing survived of the roof except small fallen slabs and the long lintel shown in fig. 5. The roof of the antechamber had presumably been level with the tops of A1 and A2 and about 2 feet 6 inches above the floor. One end of the long lintel rests on the wall orthostat C7; the other end was found resting on the filling of the east end of the cist and had originally been supported on the shoulder of C2, bearing against C3. The lower face



of this lintel, originally some 4 feet above the floor, must have determined the level of the roof over the eastern part of the chamber. The height of the roof over the main part of the chamber is determined by the heights of the broad ledge on C4 and of the tops of the neighbouring orthostats at 6 feet above the floor. If this western part of the chamber had been spanned from wall to wall by single slabs, these would have been considerably larger than the long lintel which survives, and it is rather improbable that the Iron Age house builders should have broken up and taken away such larger slabs and left the long lintel untouched. The quantity of slabs at the base of the deposit in the chamber containing Early Bronze Age pottery points to fallen corbelling. In the light of these considerations, and of local practice as exemplified in other (unexcavated) round-chambered tombs, the western part of the chamber may probably have been roofed with a circular corbelled vault springing from C3, C5, C6, the ledge of C4 and the long lintel.

Since the roof was thus tripartite, at 2 feet 6 inches, 4 feet and 6 feet above the floor, it is arguable that the western part of the chamber would most correctly be referred to as the "chamber," the eastern part as the "antechamber," and the antechamber as the "passage." This terminology would get some support from the evidences of ritual discussed below. Such considerations must, however, be somewhat speculative, and it has not seemed necessary in this report to alter the terminology used in the course of the excavations.

The façade is composed of orthostatic slabs, which increase in height towards the portal, and of panels of well-built, though now slipped, dry masonry (fig. 2). Of the orthostats, F2, F7 and F8 had been disturbed by the Iron Age activities already mentioned; the sockets of F2 and F8 were precisely determined, that of F7 only approximately. F2 is missing; part of F7 lies horizontal on cairn material as shown in fig. 1, its eastern part having apparently been broken off with a maul and removed; F8 lies intact, fallen forward over the vertically set slab which had secured its foot. The other five orthostats survive uninjured. They stand with their feet on, and not in, the original ground surface, tilted back from the vertical and resting against the steeply piled face of the cairn. Behind they are supported by massive stone abutments built into the cairn face, and are wedged out by large slabs inserted between themselves and these abutments. In front, their feet are secured from slipping outward by a tight pavement formed of slabs laid horizontally, and of small blocks or vertical slabs jammed between these and the orthostat foot. Above this layer are small slabs set generally upwards and inwards (Pl. II, 2), mixed with a few long blocks similarly set as struts, and some small boulders. The whole is compacted with small stones and earth to form a low containing bank not more than 18 inches high. The lateral stability of the orthostats is secured

by triangular gusset blocks set laterally against their feet, sometimes supplemented by slabs set diagonally (Pl. III, 2). The latter make a sort of herring-bone dry walling, and compose, together with horizontally built dry walling, the low panels of masonry that intervene between the orthostats (fig. 2).

The peristalith which walls the other three sides of the tomb enclosure was found, where excavated, to be constructed generally similarly to the façade. In the south-west corner P7 and P9 were found lying horizontal in front of their abutments; P8 is missing, but its socket is defined by an undisturbed lateral gusset slab to the east. In the south-east P10 is erect, with its lateral gusset abutment to the east of it, but beyond this the wall has been largely removed and it is not clear whether P11, of which the head is sheered off, is a peristalith orthostat set contiguously with P12, as shown in fig. 1 or whether both P11 and P12 served as the abutments for a larger orthostat. In the north-east P4 and P3 are erect, P2 is displaced to form a jamb and outer wall-face to the house and; beyond the house, P1 lies fallen forward on its face in front of its rear abutment. Throughout this much robbed section there is no trace of dry-built masonry, and the evidence from the other excavated sections is too incomplete to establish that the peristalith orthostats were regularly joined by lengths of built walling: it is very probable from the analogy of other tombs that they were, but it remains a possibility that the rough revetting of the cairn face was accepted as a sufficient wall.

Façade and peristalith had originally been fully visible features. The cairn had first been built and its faces revetted to a steep angle with slabs which formed the orthostat abutments; the orthostats had then been erected and, apart from the low containing bank which secured their feet in front, the cairn had not extended outside them. Accordingly, when orthostats subsequently fell forward they lay horizontal on their faces on the turf, and were in due course grown over with peat. As is seen from the contours in fig. 1, the depth of cairn over the western part of the tomb enclosure is slight, and over the eastern part is insufficient to reach the tops of the façade and chamber orthostats. It nowhere exceeds 4 feet and, while the disturbance caused by the building of the house makes it impossible to be sure that it was not originally mounded higher round the chamber, it can hardly have covered the roof and certainly did not reach the top of the tall western chamber orthostat C4.

The detached standing-stone is 11 feet 3 inches in total height and must have stood some 10 feet clear of the original surface. Its irregular base is supported underneath with chock stones, and its stability secured by layers of slabs laid horizontally to form a tight pavement all round the foot of the stone and bearing on the lower part of its vertical faces. The method being the same as that used to secure the feet of the façade orthostats, it seems

safe to conclude that the stone forms part of the tomb structure, despite the fact that in excavating it no finds were made.

Thus the original aspect of the tomb was a broad wedge-shaped enclosure with a conspicuous detached stone near its south-west corner, its eastern face forming a slightly bowed façade rising in height to a central portal. This façade was built of orthostats alternating with panels of carefully built masonry; the other three faces of the enclosure were walled with smaller orthostats joined by possibly rougher masonry. The contained cairn formed a more or less level platform, filling the enclosure to a height a little below the top of the façade at the eastern side, and mounded up on the southern, but standing to no more than one to two feet on the west and north. The chamber, which opened through the portal in the middle of the façade, was largely concealed, but its roof was in all probability visible and conspicuous, and its tall western orthostat certainly was.

#### *Deposits in the Chamber.*

The filling of the chamber was as follows:—

- (1) The undisturbed greenish-yellow clay which overlies the solid rock.
- (2) Except in the cist, a sterile layer 2 inches thick of charcoal-stained earth, not distinguishable in character from (4) but containing no funerary deposits.
- (3) In the cist, immediately upon the slab flooring, dark brown sticky material; this was sterile as regards its lowest two inches but above contained considerable bone remains.
- (4) Above (2) outside the cist, and above the bone layer in the cist, up to a general level of 12 inches above the clay floor, fairly finely divided earth and some small fallen slabs; the earth was dark brown in colour except where blackened by charcoal. This layer contained, outside the cist, slight bone remains.
- (5) Above (4) a considerable quantity of fallen slabs and brown earth free of charcoal. No bone was preserved in this layer.
- (6) Above (5) a layer 2 to 3 inches thick of heavily burned material consisting of earth, peat-ash and some charcoal. This layer contained Iron Age sherds, and represented the use of the partially unroofed chamber as a cooking-pit by the people who built the house. This layer is shown by a broad black band in the sections in fig. 5.
- (7) Immediately overlying (6) was the fallen roofing slab which still remains and a considerable quantity of small slabs.
- (8) Earth containing further occupational debris of the Iron Age and, in the eastern part of the chamber, a layer of peat-ash and charcoal at 14 feet to 14 feet 3 inches above datum.
- (9) A layer of peat and then the modern turf.

The cist was built on the undisturbed clay and was an original feature of the chamber (fig. 4 and Pl. III, 1). Its side slab, S1, was set in a cutting 3 inches deep in the clay, and this contained charcoal-blackened earth to its bottom. This might indicate that the debris of fires littered the floor at the time of construction but is sufficiently explained by subsequent infiltration. The space under the sloping end slabs of the cist had for some time remained hollow, since it contained three fragments, one a large one, of the vessel 10 and the indeterminate bone scraps B5 and B6 (App. I). In the course of the centuries it had filtered up and was full of the blackened earth which had silted into it from above. The end slab of the cist, S2, was not fixed, but rested against the side slab, S1.

Outside the cist the floor of the chamber was not paved. A long thin slab lay on the clay floor beside the cist at its western end, and a larger thin slab sloped slightly upward from the east end of the cist to the north wall of the chamber, where it was supported on blocks some 6 inches above the floor; bone fragments were found under its upper end and it may or may not be original. In the eastern part of the chamber a few small slabs lay erratically on the clay floor. The antechamber, on the other hand, had been levelled up with blocks of stone to the height of the chamber floor and roughly paved above this block filling.

One object was found in stratum (2) lying directly on the clay floor, a large stone ball. Stone balls have been found in other chamber tombs in positions which suggested that they were foundation deposits, and this may be such, but it could equally be a tool used in the tomb's construction; it does not appear to be a funerary deposit. Apart from the ball this stratum was sterile and may be taken to be the trampled layer resulting from the building of the tomb. Such sterile layers are normal in chamber tombs, and are recorded to have been artificially laid in some tombs in north-east Ireland.

Stratum (4), which belongs to the period of funerary use accompanied by Neolithic pottery, was heavily impregnated with charcoal, but very unequally. In the cist the filling was saturated with charcoal, and much large charcoal overlay the surviving skeleton; in the centre and west part of the chamber darkening was general, but completely blackened soil occurred in layers, which no doubt consisted of the scattered debris of successive fires; in the eastern part of the chamber there was relatively little charcoal. There was no peat-ash in this stratum, and the woods which were identified were willow, hazel, oak, pine and possibly birch; in stratum (6), which represented Iron Age use, there was much peat-ash and the only wood occurring was willow.<sup>1</sup>

<sup>1</sup> Where willow is mentioned there is the possibility that the wood may really be poplar, the two woods not being distinguishable. I am greatly indebted to Mr M. Y. Orr of the Royal Botanic Garden, Edinburgh, for the identification of the charcoals.

There was a fair number of small slabs in stratum (4), particularly near the walls; these were presumably stones used as dry walling to fill up interstices between orthostats, or to level their tops, which had worked loose and slipped down. The fact that they lay in some cases under or over pots or groups of bones lying near the west and north walls need indicate no more than that slabs already fallen might be placed to support or protect the pot or group of bones when that was placed in its present position. In the antechamber there was a considerable quantity of slabs; they were relatively evenly laid, and overlay fragments of a believedly early pot and underlay sherds of other pots which, from their stratification elsewhere, were regarded as comparatively early. It is thought that these slabs were the lower part of the blocking of the entrance after the first interment, which were not removed when the tomb was opened for the second one. A substantial number of blocks and slabs lying in the south-east corner of the chamber between C1, C2 and S2 may be either fallen dry walling or blocking material pushed inwards at the first re-opening of the tomb.

A considerable quantity of slabs at the base of stratum (5) is likely to represent some partial collapse of the corbelling of the roof upon the silted-up floor formed by the surface of stratum (4).

The thick burned layer, stratum (6), effectively sealed the funerary contents of the tomb. At the time of its laying down the still surviving roofing slab of the chamber was in place, for when it fell it was embedded in this layer; but the chamber must have been otherwise unroofed, since it was in use as a cooking-pit by the neighbouring Iron Age dwellers. The latter probably improved their shelter by building loosely on the top of the orthostats, for the immediate succeeding layer, stratum (7), was composed of a quantity of fallen small stones, as well as the then fallen roofing slab. Above this, in stratum (8), was further Iron Age occupational debris, including, in the eastern part of the chamber, the remains of further fires.

#### *The Sequence of Burials.*

A report on the surviving bones by Dr A. E. J. Cave, to whom the writer is much indebted, is given in Appendix I. In the strongly acid soil bone had survived only if heavily burned and also situated in a well-drained spot, and the sole substantial group of bones found, B3 (1, 2, 3), were those on the sloping head slabs of the cist. This group represented the extremely decayed remains of the upper half of the skeleton of a mature woman, the last burial to be made in the cist. The bones were in order, so far as could be judged in their state of dissolution, and the body had lain on the right side with head to the west.<sup>1</sup> Though much distorted by fire these bones had

<sup>1</sup> The dissolution of the bones was such that it was necessary to remove them on a trowel with the earth and to dry them in the air. This was done section by section, but, owing to a misunderstanding, the three sections were associated into a single group when examined (B3 (1, 2, 3) in App. I).

not been cremated, and their condition must be due to the piling of burning charcoal on them as they lay in the cist. Since it would be impracticable to light and maintain a substantial fire in so cramped and ill-ventilated a spot, the charcoal must have been brought into the tomb already burning, and tipped out upon the cist. Even so, the heat generated would not have sufficed to consume the flesh and heavily to burn the bones within; we must therefore suppose that the flesh was already decayed when the burning took place.

From this consideration, and from the fact that the bones had not been subsequently disturbed, it follows that, contrary to the usually accepted view, the introduction of fire into the tomb occurred at a late stage in the funerary ritual, and not as the first stage of a new funerary cycle when the tomb was being cleared for a new burial. Presumably the bringing in of the fire constituted the last stage of the funerary ritual, and was designed to drive the ghost away from its then decomposed body, and from the tomb, in order that it might take its departure to the place appropriated to disembodied spirits. It may also be inferred that the removal of the bones from the cist did not take place at this stage, but later, at the beginning of a new funerary cycle.

With the bones of the woman in the western part of the cist were found also a handful of rib bones of smaller size, and these, though much fire-distorted, can be identified as those of a younger human individual under age twenty-one. The smallness of the cist excludes the possibility that the mature woman and the younger individual were deposited simultaneously, and also the possibility that the body of the former was laid upon the skeleton of the latter. We may therefore infer that the handful of rib bones represented an earlier burial of which the remains had not been quite completely removed from the cist. In the centre and the eastern part of the cist no bones had survived save the indeterminate fragment B3 (4). Under the head and foot slabs respectively were the slight fragments B3 (5) and B3 (6); it has already been suggested that these had filtered into the hollow spaces from the slabs above.

Outside the cist the only significant groups of surviving bones are B0, B1 and B2, all lying near the west or north walls of the chamber. The group at B0 outside the cist and close to the orthostat C5 seems to be the slight residue of a detached skull. The miscellaneous collection at B1 near the middle of C6 cannot have derived from a skeleton deposited complete, but is the remains of a disordered pile of bones of which the most heavily burned and best drained parts have survived. The unidentifiable fragments found at two levels at B2 in the angle between C6 and C7, and separated from one another by the flooring slab which sloped up to the north wall, where its end was supported 6 inches above the floor, offer no significant evidence that complete burials had been made at the places where they now

lie. The most probable view is that all these bones represent bodies which had originally been buried in the cist, had been partially burned after decomposition there, and had been subsequently removed and piled against the north or west wall of the chamber. The relative absence of the debris of fires in the north part of the chamber is additional evidence that bones surviving there owed their burning to their earlier presence in the cist. The evidence provided by the pottery distribution (below) shows that piles of debris had accumulated against the chamber walls, and principally against the north wall; this, it would seem, was the normal place of disposal of removed bones, and there, with accumulated earth, they had gradually piled up to a height of not less than a foot.

A single unidentifiable chip of bone (B4) was found outside the cist at the junction of its walling slabs S1 and S2, and another (B5) in the corner between the orthostats C1 and C2.

#### *The Sequence of Pottery Deposits.*

Fourteen Neolithic<sup>1</sup> and three Early Bronze Age<sup>1</sup> vessels were deposited in the tomb; of these, one was complete, eleven have been restored, and the profiles of the other five can with varying degrees of conjecture be reconstructed (figs. 6 and 7 and Pls. IV-IX).<sup>2</sup> In addition, ten sherds survive of a cordoned vessel of uncertain type, and about twenty miscellaneous and very small sherds not attributable to identified pots. Some sherds show decomposition as a result of heat, while trampling in the centre of the chamber may have reduced some to grit; substantial parts of some pots are however missing, and as they were not found in the forecourt it must be supposed that sherds were deliberately taken away from the site, perhaps as amulets, during the period of funerary use of the tomb.

Fig. 5 shows in plan and elevation the positions of pots of which substantial parts were found associated in a group; the position is indicated by the number of the pot and, where substantial parts of a pot were found in each of two different places, each place is marked, as 1A and 1B. Reference to other sherds will be by the areas and strata shown in fig. 5; thus A1, 11 will indicate a position in area A1, stratum 11 (*cf.* Appendix II).

To save repetition, a schedule is here given of the data regarding the seventeen pots which are relevant to the succeeding discussion. In this schedule, anticipating the discussion, the pots are classified in groups representing the most probable order of their original deposition in the tomb. This classification should be understood to be tentative inasmuch as absolute stratification is, in the circumstances of the use of the tomb, an unreliable guide. Broadly the criteria which seem valid to determine relative date

<sup>1</sup> In the senses stated on p. 2 note 2.

<sup>2</sup> I am greatly indebted to Professor Stuart Piggott for the drawings in figs. 6 and 7

of deposition are: relative stratification of groups of sherds lying near one another against the wall of the chamber; relative stratification in the antechamber of sherds found there and belonging to vessels of which the main parts were in the chamber; relationship to successive clearings of the cist. These criteria, as will be seen, are far from sufficient to determine a complete time sequence.

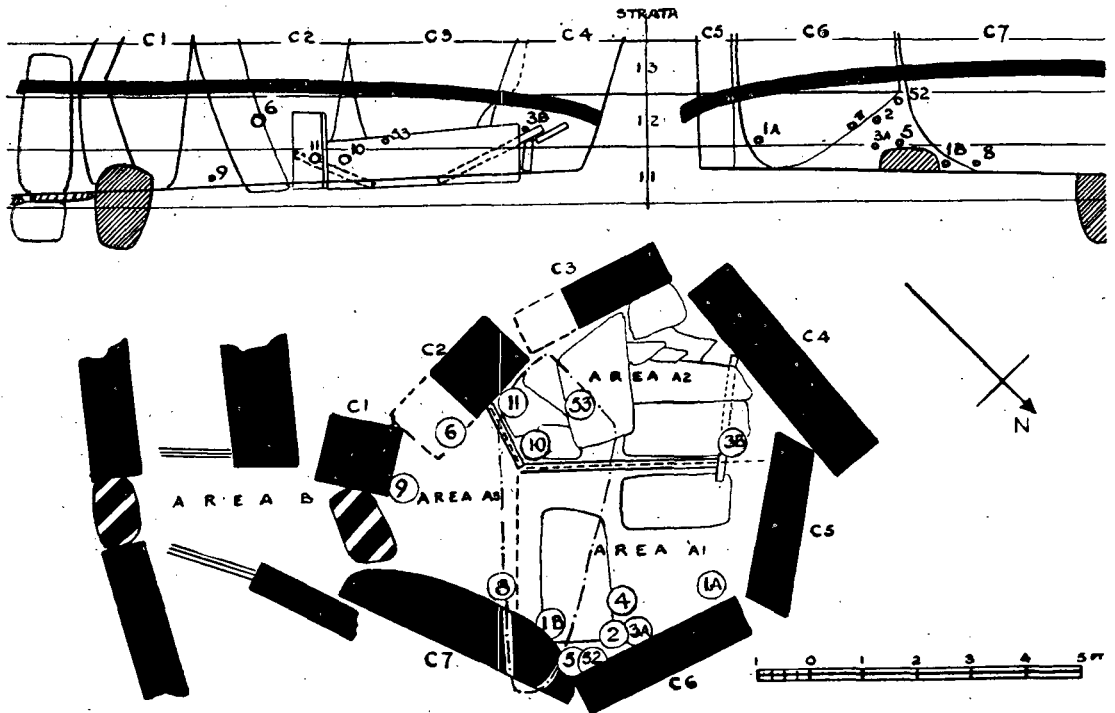

Fig. 5. Pottery Find Plan.

*Group (i).*

Pot 13. Small part surviving. Scattered in antechamber, B11, under the unremoved blocking of the entrance. Probably belonging to the first burial in the tomb.

Pot 9. Nearly complete. Main fragments at 9 at 2 inches above floor; others in A3, 11 and two in cist. Possibly belonging to the first burial.

*Group (ii).*

Pot 8. More than half surviving. Main fragments at 8 at 2 inches above floor; others in A3, 11; two in antechamber, B11, stratified over



the unremoved blocking of the entrance. Belonging to second burial at earliest.

Pot 1. Almost complete. Half at 1A at 7 inches above floor and half at 1B at 2 inches above floor. The second half had been deposited before debris had accumulated at 1B; the first half was in the pile at 1A of which the surviving bone remains are the mixed collection B1. Belonging to second burial at earliest, unless the half at 1A was placed there with the bones of the earliest burial when these were removed from the cist.

*Group (iii).*

Pot 5. Complete. This stood intact, wedged between the orthostats C6 and C7 at 6 inches above the floor and at the level of the upper end of the sloping floor slab. Being intact and wedged in the cranny, it might have been placed in its present position before debris had accumulated to a depth of 6 inches against the wall; it may therefore belong to an earlier group.

Pot 3. More than half surviving. Main fragments at 3A at 6 inches above floor; other sherds on the head slabs of the cist at 3B. The latter sherds had presumably been left behind when the main part of the pot was removed to 3A, and the position in the time order is to be judged from the level to which debris had accumulated there.

*Group (iv).*

Pot 12. Half surviving. Fragments scattered in A1, 12 except one in A1, 11.

Pot 14. Round base and part of wall and hollow neck surviving; no rim or decorated sherds surviving. Fragments scattered in A1, 12 and A3, 12 and one in A3, 11. Many sherds decomposed, apparently by reburning, and surface shaled off. (Not illustrated.)

Pot 7. Nearly complete. Main fragments in the disturbed earth<sup>1</sup> in stratum 12 against the orthostat C5; other sherds scattered in A1, 12. The pot had been heavily reburned.

Pot 51. Almost complete. All sherds were in the disturbed material in stratum 12 beside the orthostat C5, near which the pot must have been deposited. Owing to the disturbance it cannot be said whether or not this pot was stratified over pot 7, but the vertical distance between the two must have been slight. The pot may however belong to Group (vi).

Pot 2. Two-thirds surviving. Main fragments at 2 at 12 inches above floor; others scattered in A1, 12. Stratified over pots 3 and 5.

<sup>1</sup> A shepherd boy, who had watched the digging, returned and dug a small hole, limited to stratum 12, beside the orthostat C5; thence he extracted one sherd of pot 7 and two of 51. He washed these, as he had seen done, and left them beside the washing-hole on the turf. His intention was helpful, but as the remaining sherds of 51, and some of the sherds of 7, were found among the earth disturbed by his digging, the relative stratification of these two pots was most unfortunately lost.

Pot 4. Half surviving. All sherds found in a group at 4 at 9 inches above floor and probably deposited intact there. Stratified over pots 3 and 5.

Pot 6. Nearly complete. Main fragments at 6 at 12-15 inches above floor resting on a tilted slab, itself supported on fallen blocks; all other sherds among the blocks at levels down to 6 inches above the floor. Presumably intact when placed on the slab; when broken the sherds had fallen to the then level of accumulation of debris. The date of deposition was not earlier than the date of this accumulation. Stratified over pot 9.

*Group (v).*

Pot 11. Nearly complete. All sherds in a group lying on the sloping foot slabs of the cist at 11. The pot belonged to the last burial in the cist.

Pot 10. Two-thirds surviving. Main fragments in a group lying on the sloping foot slabs of the cist at 10; three sherds, including one large one, silted down under the foot slabs; three sherds in the antechamber in B, 12 and B, 13. These last were stratified over sherds of pots 8 and 13 and under sherds of pot 53. Presumably belonging to the last burial in the cist.

*Group (vi).*

Pot 53. Flat base and large part of one side and small part of rim surviving. Lower part found crushed but in order at 53 at 8 inches above the floor in the filtered earth with which the cist had by then become filled to the brim; two rim sherds and one other sherd lying alongside at the same level and two sherds in the antechamber in B, 13. These last were stratified over sherds of pots 8, 11 and 13. The part of the pot at 53 had been crushed under the lower edge of the fallen roofing slab, the great weight of which had pressed it down into the loose filling of the cist on which it had been lying, and had pressed on top of it the thick burned layer representing the first Iron Age use of the chamber as a cooking-pit.

Pot 52. Small part surviving. Flat base at 52 at 15 inches above floor; two rim sherds and one other sherd scattered in A1, 12. Stratified over pots 1, 2, 3, 4, 5 and 8. This pot appears to be the latest funerary deposit in the tomb.

*Distribution of Surviving Sherds.*—Fig. 5 shows, from the plan, that pots were deposited either in the cist or against the walls of the chamber; and, from the profiles, that the accumulation of debris against the walls had been greatest on the north side against the orthostat C6 and in the corner between C6 and C7. It has already been suggested that this growth of debris resulted from use of this part of the chamber for piling bones removed from the cist. That the accumulation here formed a solid pile we can infer from the fact that sherds of the pots of which the main fragments were against

this wall had not filtered down to lower levels. This is in contrast to the position in the south-east corner of the chamber where, though the main fragments of pot 6 were at a high level on a slab resting on fallen blocks, sherds of the pot had filtered down among the blocks to a level of 6 inches above the floor, a level which evidently was that of the accumulation of debris at the time. This uneven rate of accumulation must be borne in mind in judging stratification.

The indications of the disturbance of pots and the scattering of sherds must also be considered. There is ample evidence of the disturbance of pots in the cist. Against the north wall and in the south-east corner, on the other hand, there can have been little disturbance, for pots 4, 5 and 6, though two of them were broken, remained unscattered. In the centre of the chamber there had been heavy trampling and all the sherds found were small. In the eastern part, area A3, three pots had been deposited against the walls, but apart from these no sherds were found except a few of pot 14, the slight remains of which were divided between areas A3 and A1. It would seem that, outside the cist, pots had remained very much where they were put, whether on original deposition against the walls or on removal from the cist and disposal against the walls.

In the antechamber, under the 6-inch layer of slabs which, it has been suggested, represented unremoved blocking, were the surviving parts of pot 13; above that layer were two sherds of pot 8, and above these three of pot 10, and above these two of pot 53. The total depth of deposit containing sherds, including the slab layer, was 20 inches, the greater depth of deposit as compared with the chamber being due to the downward slope of the chamber floor towards the door and to water-silting of earth against the door blocking. The presence in the antechamber of two to three sherds of each of the pots 8, 10 and 53, and particularly the presence of sherds of pot 10, of which the remainder was wholly on or under the sloping foot slabs of the cist, can hardly be attributed to chance. An explanation, which would account also for the loss of some part of nearly all the pots in the chamber, is that parts of pots were taken from the tomb as amulets, and that some of these sherds were dropped in wriggling out of the narrowly constricted entrance. In the light of the evidence of the last burial, to which pot 10 belonged, this would have occurred at the final stage in the funerary ritual when burning charcoal was placed on the cist and, as has been supposed, the ghost was driven from the tomb.

*Deposit of Pots in the Cist.*—We have seen that there were probably two pots, 10 and 11, which were placed in the cist with the last burial there. There is positive evidence that pots 3 and 9 had originally been deposited in the cist and later, when broken, removed thence, since sherds of each were found there. There is presumptive evidence that some other pots had originally been in the cist. Thus, in the case of pot 1, it appears a good

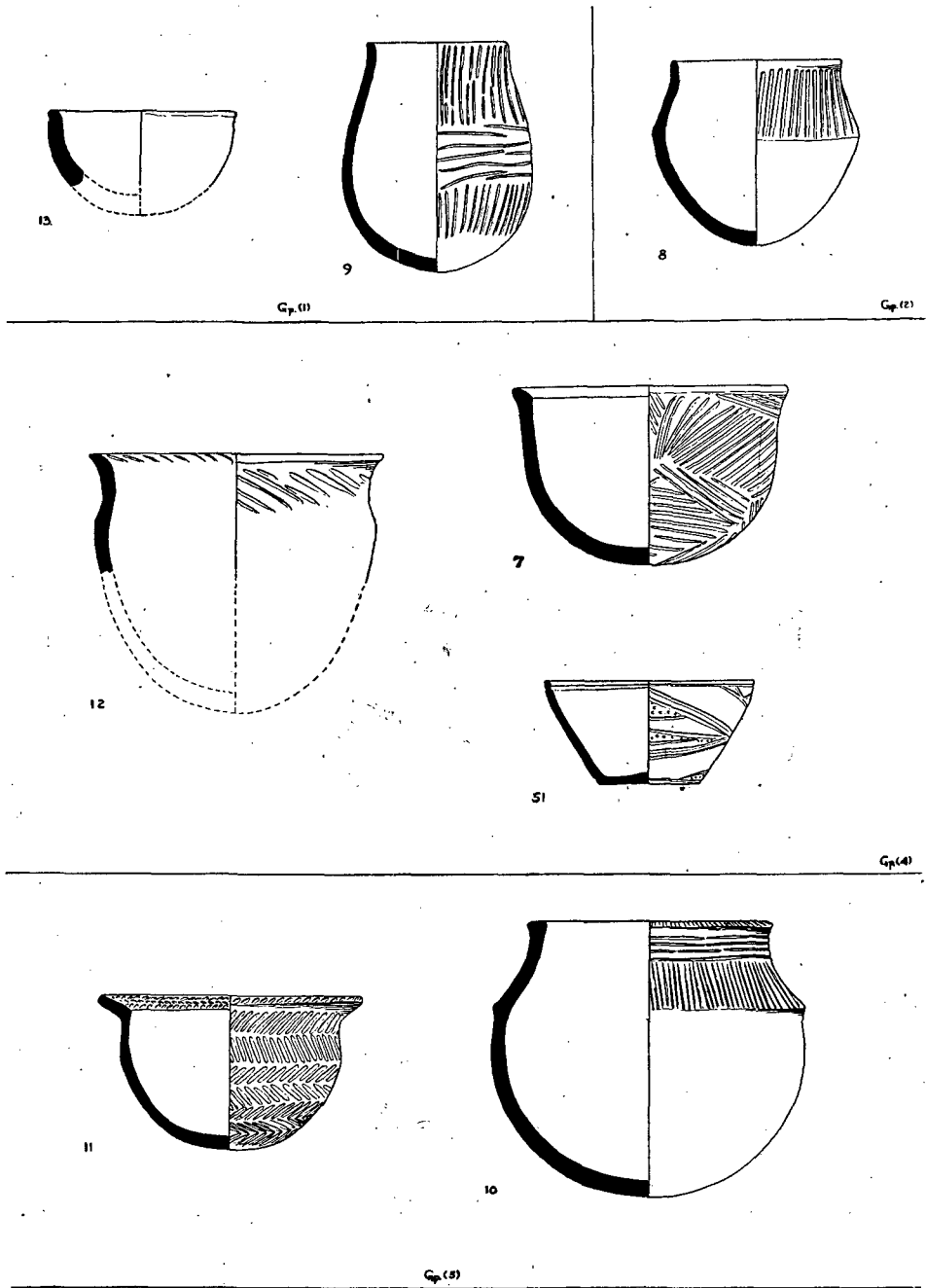

Fig. 6. Reconstruction of Funerary Pottery.

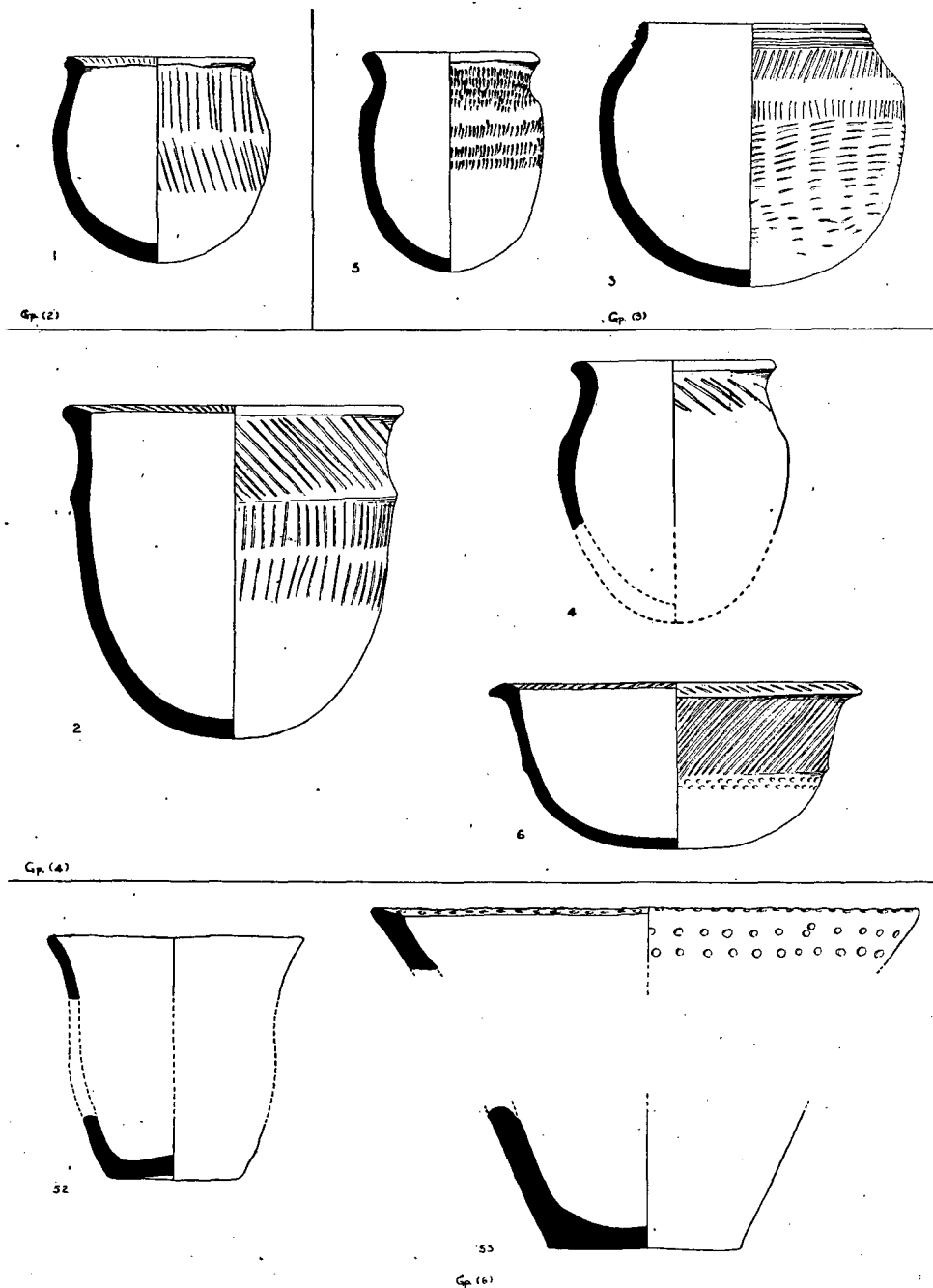

Fig. 7. Reconstruction of Funerary Pottery.

deal more likely that the pot was broken when in the cist, and the two halves removed to 1A and 1B, than that, originally deposited at (say) 1B, it was broken there into two and one-half systematically removed to 1A. The best explanation of the scattering of some of the sherds of pot 2 in area A1 is that this occurred in the course of shovelling out debris from the cist, the main part of the pot being at that time placed against the north wall; for it is placed behind the undisturbed vessel 4 in a position in which the chance scattering of a part of the pot is not likely. Again it is more probable that pot 7, which was heavily reburied, was so reburied in the cist than in its present position against the west wall of the chamber.

No good grounds appear however for supposing that the ritual contemplated that all pots should be deposited in the cist. On the contrary it is unlikely that pot 5, which is intact, and pots 4 and 6, which were probably intact when deposited in their present positions, were first deposited in the cist; for the last burial shows that pots were not removed from the cist before burning charcoal was placed there, and it is not at all probable that such pots would come through both unbroken and without showing signs of reburial. It would seem, therefore, that the ritual allowed of pots being placed either in the cist with the body, or against the chamber walls; or, alternatively, that it required them to be placed in both places. If the latter, and if the practice of the last burial of placing two pots in the cist was typical, three or more vessels might be devoted to the dead, and the total number of burials in the tomb accompanied with Neolithic pottery need not have been more than four or five. This is not incompatible with the stylistic development shown by the pottery: the pottery kilns successively in use at Eilean an Tighe, North Uist, have produced a series of vessels showing a longer stylistic development, yet their use cannot plausibly be spread over much more than a century.<sup>1</sup>

*The Ritual.*—On these data the ritual may be tentatively reconstructed as follows. The first stage (except in the case of the first burial) would be the clearance of the cist: the substantial bones would be piled against the wall, normally the north wall, of the chamber; the large parts of broken pots would be removed from the cist and placed against the walls of the chamber; the residuum of earth, decayed matter, charcoal, small bones and small sherds would be shovelled out on to the chamber floor alongside the cist. The next stage would be burial in the empty cist: one or more pots, perhaps normally two, would be placed with the body in the cist; one or more pots might also be placed for the use of the dead against the chamber wall. The third stage would occur at some determinate time after the burial when the body was decomposed: burning charcoal would be piled upon the

<sup>1</sup> A preliminary report on this site was made to the Royal Anthropological Institute in January 1939, and a brief note on this is in *Man*, March 1939. A verbal report was made to the Society in February 1949.

cist to drive the now disembodied ghost from the tomb; sherds, and perhaps bones also, might be taken away as amulets.

*The Later Burials.*—The ritual which it has been attempted to reconstruct above continued in use throughout the period of use of Neolithic pottery; pot 9, which is stratigraphically one of the earliest in the tomb, had been deposited in the cist, and pots 10 and 11 had accompanied the body last deposited there. During this period, and during the time that occurred before any later burial was made, earth had silted through the roof, and debris had accumulated, to a depth of generally 12 inches above the floor, while the cist had silted to the brim. The overlying stratum (5) was composed of brown earth, free of charcoal or other signs of burning, and no traces of bones were preserved. Over the middle of the cist and 8 inches above the floor, pressed down into its loose filling by the great weight of the fallen roofing slab, of which the edge lay upon it, was the Rinyo II type pot 53. Against the north wall at 15 inches above the floor, and separated from the highest Neolithic pot by 3 inches of accumulated deposit, was the Beaker type pot 52, which is stratigraphically the latest in the tomb. In the eastern part of the chamber at 12 inches above the floor was the pumice pendant in the shape of a flat axe shown in Pl. IX, 4.

Clearly a change had taken place in the ritual. The cist was no longer used; fire was no longer brought into the tomb; and bodies were laid on the level floor of the silted-up chamber, accompanied apparently by a single vessel. Assuming the pendant to have been hung from the neck, the burial it accompanied was laid with the head to the east. Since at this stage the level of the floor of the antechamber was certainly too high to allow a corpse to be brought in through the door, the body must have been introduced by removing part of the roof. Entry could be obtained either by lifting off the capstone of the corbelled vault or by removing a sector of the vaulting; neither process need disturb the vault's stability, and many corbelled vaults stand incomplete to-day. In entering the chamber and lifting down a heavy body a good many slabs might however get displaced, and the quantity of fallen slabs at the base of stratum 5 may reflect such efforts.

*The Time Order of Deposition.*—In the schedule on pp. 16–18 the pots are arranged in groups believed, on a balance of probabilities, to represent the time order of deposition, and the data available for forming a judgment are set down. Only an incomplete, and manifestly tentative, assignment to successive burials is possible. Pots 13 and 9 (Group i) may with some probability be assigned to the first burial, pots 8 and 1 (Group ii) to the second. The second pot in each of these two groups had probably been originally in the cist, while the first pot may or may not have been; either burial may have been accompanied by a pot or pots placed against the chamber wall, but there is no sufficient evidence to identify these. Pots

11 and 10 (Group v) accompanied in the cist the last burial made there. The pots in Groups iii and iv are likely to have belonged to intermediate burials, though, of those that were originally deposited against the walls, pot 5 may have been an accessory vessel belonging to an earlier burial, and pots 4 and 6, accessory to the last burial. Owing to the accident already described the position of pot 51 relative to pot 7 is unknown, and it may be that it should be attributed to an intermediate burial or that it was an accessory vessel deposited against the west wall with the last burial in the cist. If we relied on accepted stylistic grounds it would be natural to attribute it to a burial after Neolithic pottery had gone out of use; but such grounds are unsafe, and the small depth of deposit in the vicinity of the orthostat C5 below the sealing burnt-layer in the upper part of stratum 12 makes it questionable to allot it to a group other than Group iv with pot 7.

*Food Deposits.*—There were no surviving animal bones, but scrapings from the interior of two pots, one from the Neolithic pot 14 and one from the Rinyo II type pot 53, were examined in the British Museum laboratory and were reported probably to be the remains of food.<sup>1</sup>

### *The Pottery.*

A schedule of the pottery is given in the preceding section, and the form and decoration of the pots are shown in the illustrations. A descriptive catalogue of the individual vessels would add little or nothing, and a full analysis of the Hebridean pottery sequence can best await the publication of the much larger and more representative series from the kiln site of Eilean an Tighe, where the Unival vessels were probably made. It will suffice here to note briefly the data derivable from the tomb itself.

The Neolithic pottery is thin, hard and well baked, with crushed rock grits, mostly small. It is well formed and smoothed, sometimes highly burnished, but the surface has in part disintegrated. The colour, both on the surfaces and internally, is predominantly grey, but verging into either black or brown. Some sherds which have been reburned are brick-red, and their surface has become dusty and easily rubbed off. A test

<sup>1</sup> I am much indebted to Dr Plenderleith for examining the two samples, on which he reports as follows: "I consider that they are certainly not from cinerary urns owing to the absence of phosphate and of calcium in any quantity, and they are probably therefore the remains of food."

#### *Scrapings from Pot 14.*

Colour: black.  
Partly organic.  
Residue after incineration = 17.12 per cent.  
Composition of ash: mostly sand and some iron oxide with traces of alkaline salts. No phosphate or calcium.

#### *Incrustation from Pot 53.*

Colour: deep brown.  
Partly organic.  
Residue after incineration = 20.44 per cent.  
Composition of ash: mostly sand and some iron oxide with traces of calcium, sulphate and chloride. No phosphate.

I should say that the sand and iron oxide have come from the pot most likely."



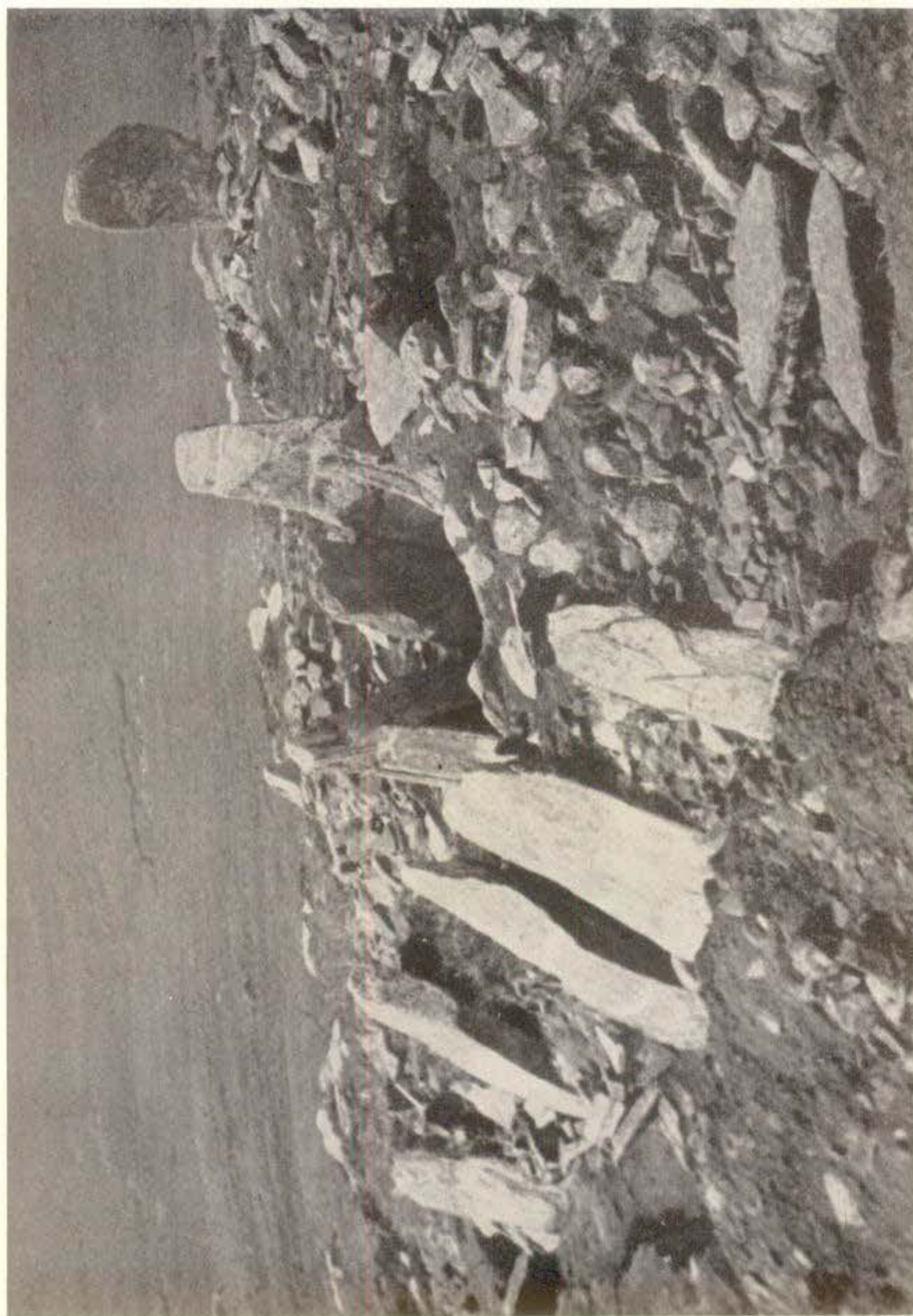

General view of tomb. Excavated chamber in centre; façade partially excavated below;  
independent standing stone top right.



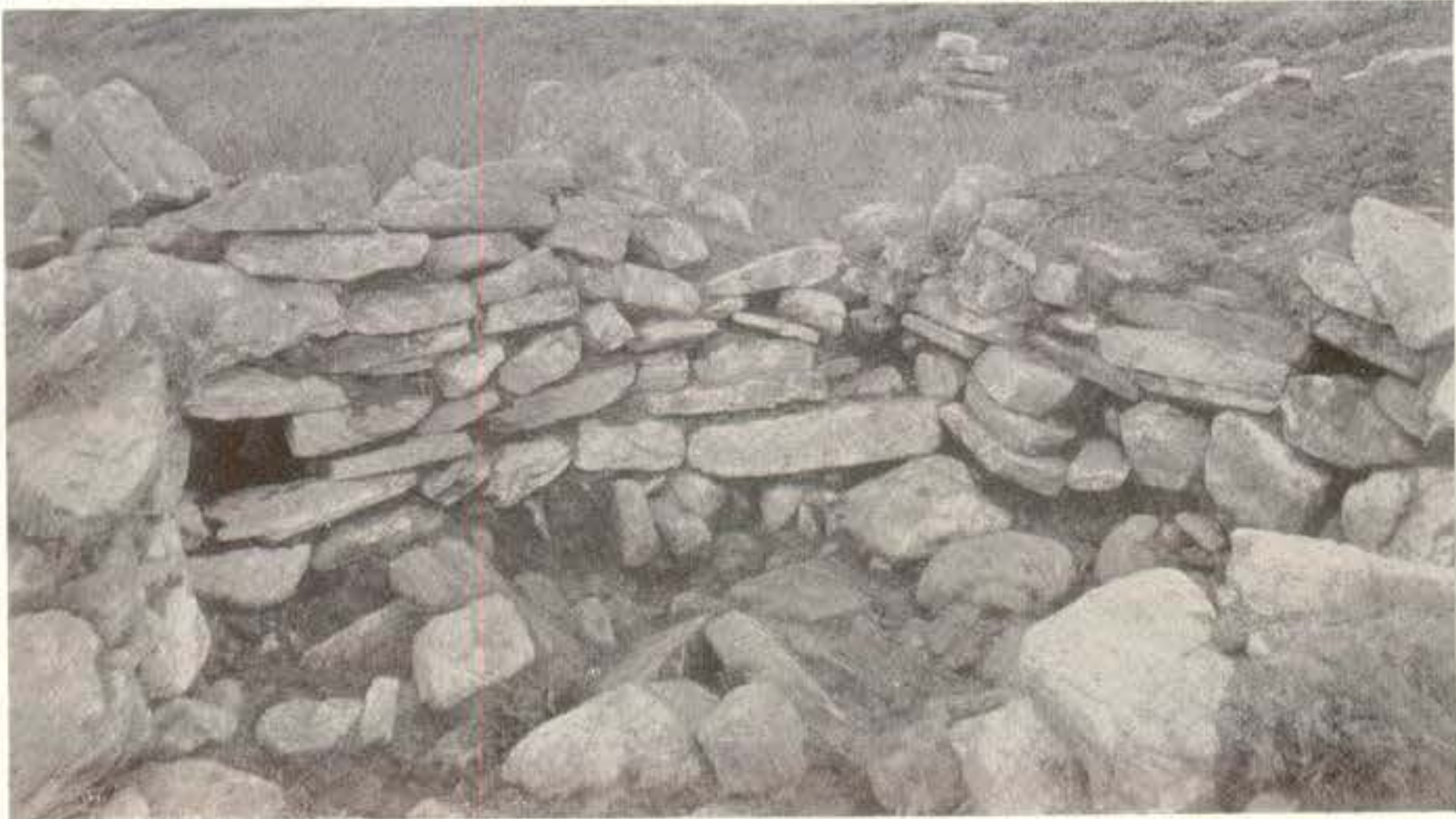

1. Iron Age House, looking north.



2. Portal of tomb, with part of retaining ramp in right foreground.

SIR LINDSAY SCOTT.





2. Southern end of façade showing triangular gusset block and diagonal walling.

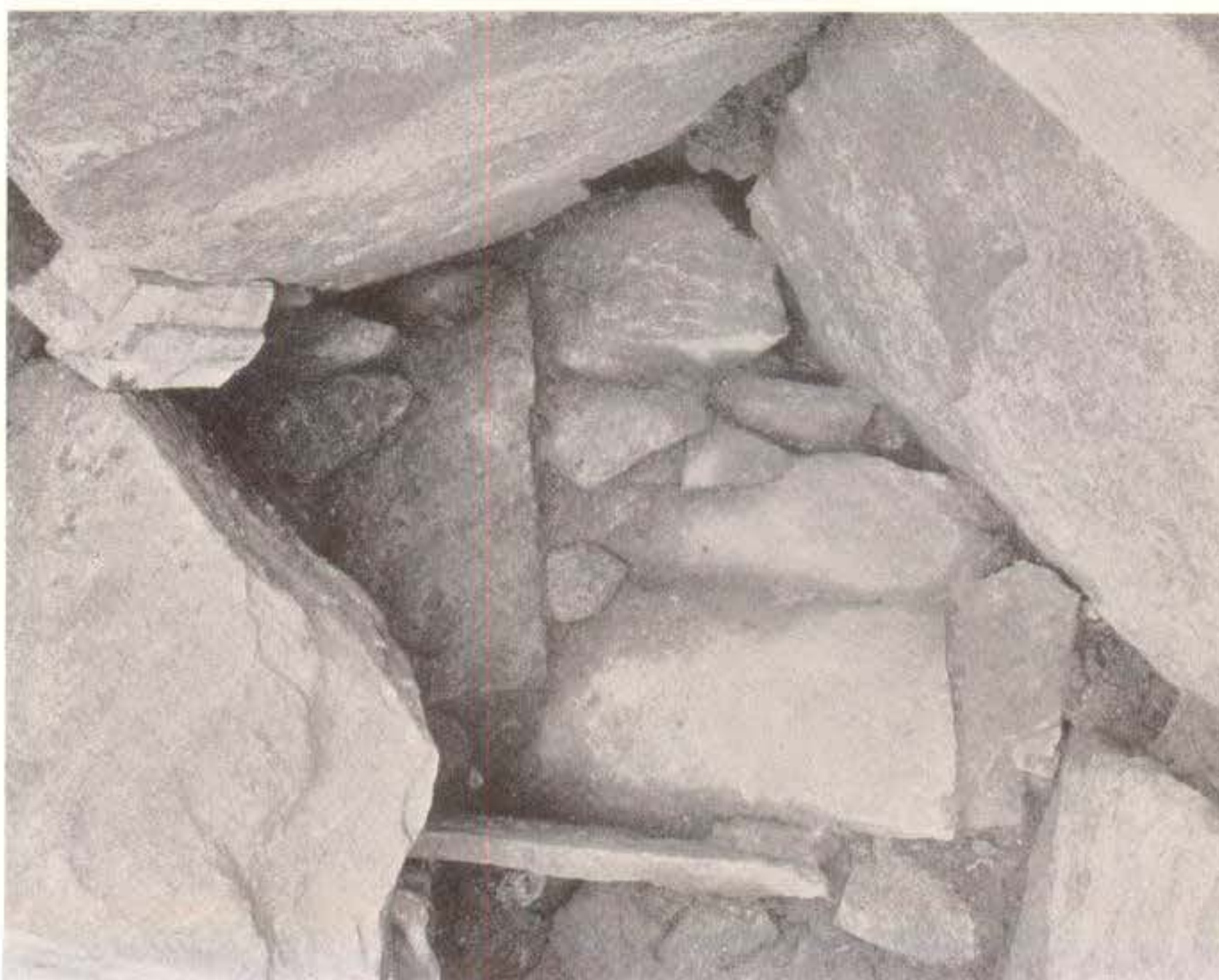

1. Vertical photograph of cist: sloping head slabs in lower part and flat bottom above. The foot slabs of the cist are hidden by the fallen lintel at the top left.





1. Pot 9 ( $\frac{1}{2}$ ).



2. Pot 8 ( $\frac{1}{2}$ ).



3. Pot 1 ( $\frac{1}{2}$ ).



4. Pot 5 ( $\frac{1}{2}$ ).

SIR LINDSAY SCOTT.





1. Pot 3 ( $\frac{1}{2}$ ).

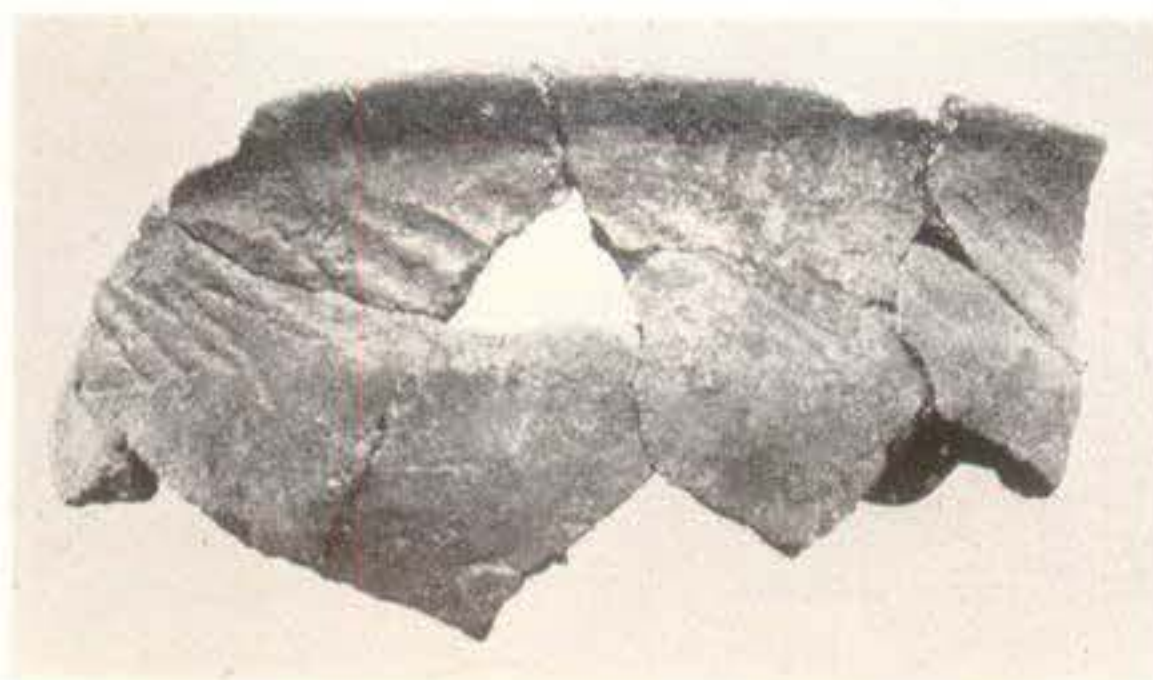

2. Pot 12 ( $\frac{1}{2}$ ).



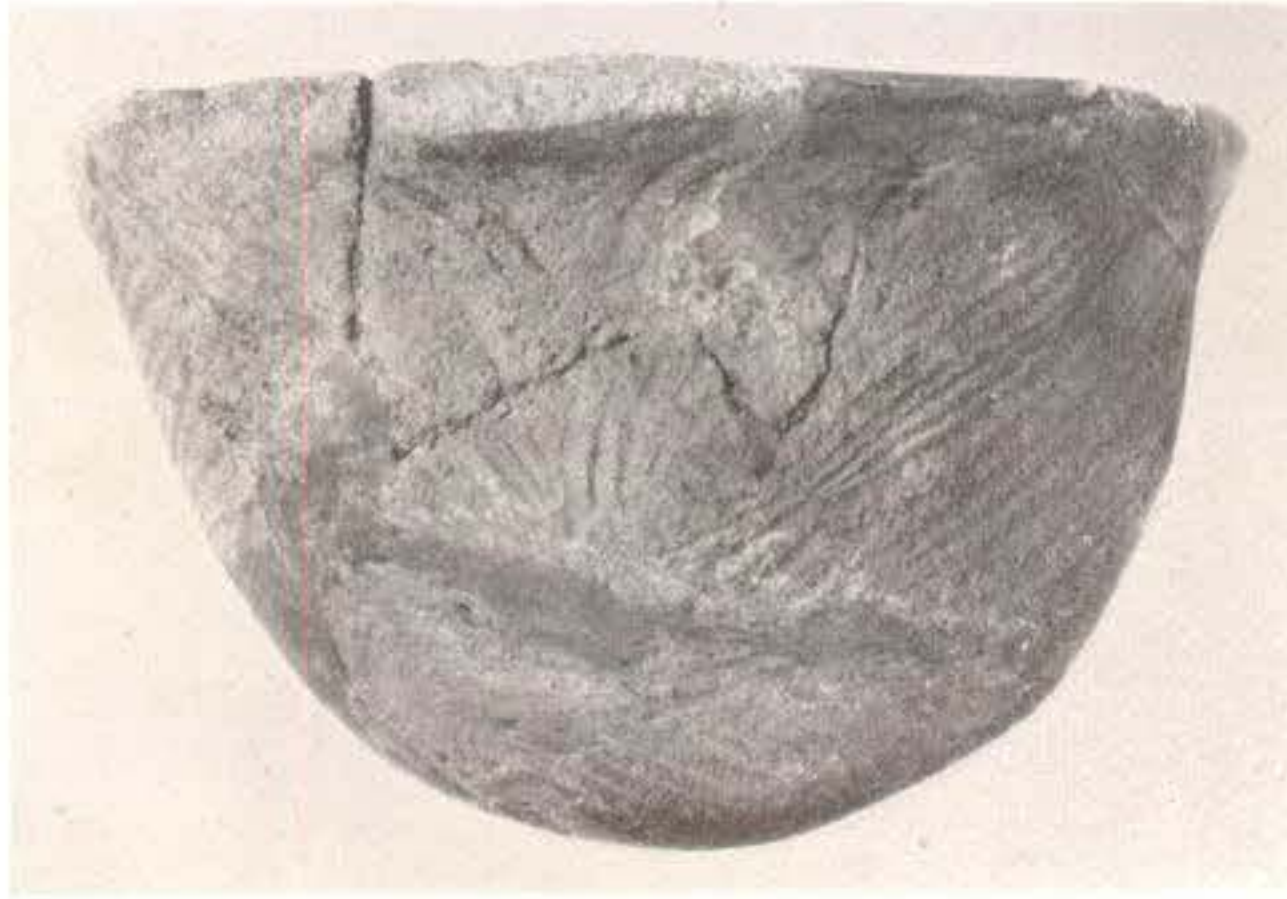

1. Pot 7 ( $\frac{1}{2}$ ).



2. Pot 2 ( $\frac{1}{2}$ ).

SIR LINDSAY SCOTT.





(Upper) Vessel from Unival Chamber Tomb, North Uist. Scale (1).

(Lower) Development of pattern on above. Scale ( $\frac{1}{2}$ ).

[From *Proc. Prehistoric Society*, 1938.]

SIR LINDSAY SCOTT.





1. Pot 4 ( $\frac{1}{2}$ ).



2. Pot 6 ( $\frac{1}{2}$ ).





1. Pot II ( $\frac{1}{2}$ ).



2. Pot 53, rim ( $\frac{1}{2}$ ).



4. Pendant ( $\frac{1}{2}$ ).



3. Pot 10 ( $\frac{1}{2}$ ).

examination by petrological analysis showed the pottery to be of local manufacture.<sup>1</sup>

Viewing the Neolithic pots in the order tentatively established in the preceding section of their deposition in the tomb, and in which they are arranged in figs. 6 and 7, the following provisional comments suggest themselves regarding the stylistic development. As regards form, small and relatively narrow globular pots tend to give way to larger and broader pots and to bowls; rim form develops from simple to complex types, including the internal bevel; carination does not occur in the two pots believed to belong to the first burial. As regards ornament, the only plain pot is believed to belong to the first burial (though the fragmentary pot 14 in Group iv may also be plain); decoration is initially, and throughout the whole series predominantly, by grooved lines; decoration by short strokes develops during the series; decoration by circular depressions or dots occurs once only and late in the series; the outlining of decoration by groups of parallel grooves below the rim develops during the series; and, as the rim develops, it becomes a vehicle for decoration. Any deductions from so short a series of pots must however be very tentative and liable to revision when a wider study of the Hebridean pottery sequence has been undertaken, but it may be noted that the general effect of a survey of the Hebridean and the Orkney pottery is to show that in substantial part it derives from a branch of the Western Neolithic family distinct from the South British Windmill Hill branch. Contrasting examples are: pot IC2 from Cletraval, which is typically Windmill Hill; pot 9 from Unival, for the shape of which it is necessary to look to Brittany or beyond,<sup>2</sup> and the Unstan bowl, for which the prototypes are in Languedoc and Iberia.<sup>3</sup>

<sup>1</sup> See a note on "Local Manufacture of Neolithic Pottery," *P.S.A.S.*, lxxvi. 130 ff.

<sup>2</sup> *E.g.* to Manio (*l'Anthropologie*, lxiv, 486, fig. 1).

<sup>3</sup> For Hebridean examples of the Unstan bowl derived from the late stage of the Eilean an Tighe kilns see Mrs Hawkes in *Arch. J.*, xcv, pls. IIA and VA (lower); for an example from the Moray Firth see R. B. K. Stevenson in *P.S.A.S.*, lxxx, 142 and pl. xxiv, 2. There is a Languedoc example from the Grotte des Sables, Remoulins, in the Nîmes Museum, unpublished. Comparison with the South Iberian pottery sequence is now possible as a result of Dr Leisner's *Die Megalithgräber der Iberischen Halbinsel*, part I. Following the exhaustive analysis there undertaken, which unfortunately cannot be based on stratigraphy, it appears that, as in the Hebrides, there was a development from narrow and mainly globular pots to more open vessels and hemispherical and shallow bowls. Carinated vessels belong in the main to this later stage, but do not become common except in the Argar Culture, the pottery of which can now be seen to be a development of forms previously current in Southern Iberia. In that culture occurs, though not very commonly, the form with high carination and hollow neck which is characteristic in North-west Britain (*cf.* Leisner, *op. cit.*, pl. 161, line 10, column L). Prof. Pericot has shown this form to be an equally advanced one in Catalonia (*La Civilización Megalítica Catalana*, 40). (This circumstance may have chronological significance, since the Argar Culture can be broadly correlated with the Wessex Culture through the segmented fayence beads of Fuente Alamo, for the substantial identity of which with examples from Wessex see E. T. Leeds, *Homagem a Martins Sarmento*, 402-4.) Also in the later stage, though south-western and unrelated to the Argar Culture, is the shallow dish with upright sides and slightly curved, and later flat, base, which is the analogue of the Unstan bowl. In this dish, and also in the bowls which characterise this later stage, there occurs the development of the rim into thickened forms with flat top and often external or internal bevel, and also into the rolled-over form—of which, it may be noted, there is an example in the Arles Museum,

Of the remaining pots, 52 is apparently a B beaker of rather poor technique and, so far as the surviving parts show, undecorated; the paste is reddish to greyish brown throughout and the fairly well smoothed surface is corky. No B beakers have hitherto been found in the Northern Hebrides. The absence on the Atlantic route of beakers which could plausibly be supposed to have come by that route has been an unresolved antinomy. This example goes a little way to its resolution, since undecorated B beakers are common in Brittany; and some slight further support for an Atlantic route derivation is provided by the restored Cletraval beaker and the fine corded B beakers from habitation sites from Luce Bay to Sanna Bay, Ardnamurchan.<sup>1</sup>

The remarkably fine dish 51, which in technique is similar and equal to the best beakers, is clearly related in decoration, and probably in shape, to the group of pots from Rinyo "all found close to virgin soil under the floors of chambers C and D"; as also to the similar groove and dot ornamented Skara Brae ware which Professor Childe there named Class C.<sup>2</sup> This ware, which at Rinyo preceded the relief decorated wares (Rinyo II), with which occurred a beaker, may best be called Rinyo I ware, and may or may not have been contemporary with the small amount of undecorated Neolithic pottery from the lowest levels of the site. All the pottery from the villages is of much poorer fabric than the Unival dish, though the Rinyo I ware is sometimes thinner than the Rinyo II, but it is to be remembered that, even in the second millennium, Orkney was dependent on peat fuel and that its pottery is generally correspondingly ill-fired.

In the present unresolved chaos of Early Bronze Age cultures it is only possible to catalogue the wider analogues of the Unival dish. Thus there are analogies with Woodhenge ware, and shape as well as decoration can be paralleled at the Lion Point, Clacton, site, though the similarities in decorative technique are less impressive when the pots are compared than they

unpublished, from the Grotte des Fées. In the dishes decoration may occur on the upright side; in the bowls on the flattened rim-top and in a band below the rim. Decoration never becomes common in the South and its more extensive use probably derives from the Tagus Estuary cultures, of which we still know little that is precise. They are not dealt with in Dr Leisner's first volume and his analysis there does not suffice to distinguish the stage of its earliest introduction on the shallow dishes and the bowls. Some indication may be obtained from data enigmatically recorded long ago by Bonsor regarding two neighbouring, and evidently not contemporary, sites at Acebuchal, where the marshy lower reaches of the Guadalquivir begin to give place to limestone uplands suitable for traders and settlers. Each site showed storage pits filled with rubbish, and a comparison of the two seems to show that the shallow dish and the shallow bowl were developed, and the rim forms partly developed, before the introduction occurred, no doubt by water, of the extensive use of decoration in the style of Palmella (*Les Colonies Agricoles de la Vallée du Bétis*, 22, fig. 3 and, respectively, pp. 30-34, 107-8 and 88-90, 116-123). It appears accordingly that there is a broad correspondence between the pottery sequences of South Iberia and of the Hebrides. The Orkney settlement, of which the pottery is dominated by the Unstan bowl, took place after the Hebridean settlement in which that type is late—as it is in Iberia.

<sup>1</sup> *P.S.A.S.*, lxix. 480 ff., figs. 13 and 36; lxviii. 146.

<sup>2</sup> *P.S.A.S.*, lxxiii. 25, and pl. xxii, A, 1-8; *Skara Brae*, 131, and pl. xlv.

are in drawings.<sup>1</sup> At Clacton this ware preceded A beakers, and at more westerly sites it occurred contemporaneously with Peterborough pottery and with B beakers. Another analogue is the bowl from the deposits at the feet of the stones of the Avebury Avenue, other deposits being B beakers.<sup>2</sup> The best analogies for the decoration are however provided by the Aldbourne cups deriving from the richly furnished graves of which there is a concentration in Wessex and from which Professor Piggott has sought to deduce a specific Wessex Culture.<sup>3</sup> In shape also the dish can be paralleled in these barrows: in one of those at Winterbourne Stoke, and in the Manton barrow which produced the gold-mounted amber disc precisely resembling a disc in a L.M. II tomb at Knossos which must be an import from the British Isles. The Manton barrow can accordingly be dated to about 1450 B.C., and that the whole group of graves is not distant in date from this is confirmed by the number which contained segmented faience beads of a type probably exported from Egypt c. 1400 B.C. The Aldbourne cups and grape cups of the tombs derive from the Chassey type wares of the Breton chamber tombs, habitation sites and Er-Lannic, and one of the chamber tombs is further linked with the Wessex barrows by a faience bead and another by gold sceptre mounts.<sup>4</sup> The Chassey type wares of Brittany are believed themselves to derive from Languedoc pottery contemporary, or at least overlapping, with the groove-decorated wares which are ancestral to the Neolithic pottery of Unival, and not greatly anteceding beakers and segmented beads of bone and faience. In these circumstances the Unival dish and the analogous Rinyo I ware of the Orkney villages can with reasonable security be attributed to movements along the Atlantic route at a date near the middle of the second millennium. Supporting evidence is provided by the remarkable resemblance of the dish to the Folkton drums, of which the Mediterranean origin is not in doubt and of which the date is fixed earlier than that of a beaker with cordon below the rim.<sup>5</sup>

Pot 53, of which the base and internally bevelled rim might suggest a vessel within the food-vessel type, appears on reconstruction to be flower-pot-shaped. Its coarse fabric is inadequately smoothed by a thick buff slip, which has disappeared from the rim, and its crude decoration is by lines of large circular pits. In shape, rim-form and texture it agrees with a number

<sup>1</sup> *P.P.S.*, 1936, 190, figs. 4, 5-7; cf. pl. xl, 7-10, for an impression of the different character of the tooling employed. The terms "grooved ware" and "channelled ware" are both avoided here as being mutually confusing.

<sup>2</sup> *P.P.S.*, 1935, 147, and pl. xvi. Professor Piggott has compared this bowl with a group of handled bowls, for which see *P.P.S.*, 1938, 98, fig. 23, and Abercromby, *Bronze Age Pottery*, I, pl. xxii.

<sup>3</sup> *P.P.S.*, 1938, 69 ff.; cf. also 115 ff. For a note on the Chronology of the Wessex Culture see Appendix III below.

<sup>4</sup> For references see Appendix III below.

<sup>5</sup> *British Museum Bronze Age Guide*, 80 ff. and figs. 74, 5; Abercromby, *op. cit.*, I, pl. xiii, 152; information from Professor Piggott. A stray find from Los Millares (Leisner, *op. cit.*, pl. 155, 3) has a grooved spiral which may be compared with that on the Rinyo I pot from Skara Brae, which site also produced segmental beads of bone.

of the pots from the Orkney villages, but pit decoration is not known there.<sup>1</sup> Such ornament is however common in Woodhenge ware, particularly at the type site, and in that ware the flower-pot and the vertically-sided pot are the two common shapes. That the Skara Brae and Woodhenge wares were related was first demonstrated by Professor Piggott,<sup>2</sup> and Professor O'Riordain has recently argued that the coarse pottery which succeeds Neolithic A wares at Loch Gur is related to both.<sup>3</sup> An examination of the coarse pottery from the Loch Gur site of Knockadoon C shows the rim form to be very uniformly flat-topped or internally bevelled, and, so far as indication can be got from sherds, the shapes to be predominantly vertical-sided or flower-pot-shaped. Decoration however, which is rare, is by grooved or incised lines, either parallel or meeting or crossing one another at an angle, and forming apparently very erratic patterns, and the connection suggested with Woodhenge and Skara Brae wares is correspondingly doubtful. However that may be, we may distinguish a western pottery family characterised by coarse, vertical-sided or flower-pot-shaped vessels decorated with cordon, boss and pit ornament. Ancestors for such a family are to be found in the coarse jars and flower-pots imperfectly known from the Catalan and Languedoc caves,<sup>4</sup> but providing in their elaborate cordon and boss ornament convincing originals for the Rinyo II ware (Skara Brae A and B) and for early and elaborately decorated encrusted urns<sup>5</sup>; the Aude-Garonne river route through the Carcassonne gap provides the necessary means of transport. Our poor knowledge of the southern material is to some extent supplemented by the material found with beakers in the upper stratum of the Pinnacle site in Jersey; here coarse jars were straight- or barrel-sided with relief decoration in straight or curved finger-tipped cordons, while boss decoration occurred on the Chassey type wares of the lower stratum.<sup>6</sup> If this south-western source proves to be the true origin of these types, Woodhenge ware would represent the coalescing of the two classes of decoration discussed in this and the preceding paragraph and represented in Orkney by Rinyo I and II respectively.<sup>7</sup>

<sup>1</sup> *P.S.A.S.*, lxxiii, 23, 24, and verbal information from Professor Childe.

<sup>2</sup> *P.P.S.*, 1936, 201.

<sup>3</sup> *P.P.S.*, 1946, 148. This pottery is not yet published, and I am greatly indebted to the courteous facilities extended to me in the National Museum in Dublin for its examination, and to Professor O'Riordain for discussion by letter. The further tentative suggestion of the latter that the ware is related to the Glencrutchery ware of the Isle of Man is not borne out by a comparison of the rim forms—a conclusion which I understand Mr Megaw to share (*P.P.S.*, 1947, 151, fig. 6).

<sup>4</sup> The best account is to be found in L. Pericot, *Historia de España*, i. 120 ff., and plates.

<sup>5</sup> The comparison was first made by Professor Childe in 1928 (*P.S.A.S.*, lxiii, 273); see also *Prehistoric Communities*, 88.

<sup>6</sup> Jacquetta Hawkes, *Archaeology of the Channel Islands*, ii. 78 ff. Relief decorated ware occurs in Brittany, at Peu Richard on the Garonne route and at Chassey on the Rhone route, but details of this material are lacking.

<sup>7</sup> A western origin for this pottery may be the more readily accepted that Professor Piggott's search for an origin in the Low Countries (*P.P.S.*, 1936, 197 ff.) produced so little by way of prototypes for the decoration and no class of vessels combining the shape with the relevant decorative techniques. The



*Stone, Pumice and Flint.*

The large stone ball already mentioned is about  $3\frac{1}{2}$  inches in diameter; it has been shaped by pecking, but has two relatively flat facets which show signs of grinding, and one of these has been battered on a pointed object. Large balls such as this are clearly capable of practical use as hammers, and two have been found in a domestic context at Rinyo and three in the Ronaldsway house.<sup>1</sup> Two were found in the socket in which a façade orthostat had stood at the Clétraval chamber tomb (and there interpreted as ritual deposits)<sup>2</sup>, and smaller stone balls, which do not suggest practical use, are known from the chambers of Irish tombs.<sup>3</sup> If they were deposited ritually it would appear from their locations that they were dedicated as part of the constructional rather than the funerary ritual; but the natural explanation is that the balls were building tools left on the site as objects unsafe to remove.

The pumice pendant, which is broken at the perforation, appears to belong to the family of axe pendants, or perhaps rather, from the direction of their perforation, adze pendants, which is widely distributed in Europe from the Central Mediterranean to Brittany. While pendants are known in the Irish passage graves, and spread thence to the Wessex Culture, the only one of the axe type hitherto recorded for the British Isles is that from the small gallery of Harristown, Co. Waterford, where it accompanied a primary cremation.<sup>4</sup> This specimen, like almost all the Continental ones, imitates a stone axe or adze, although it, and most of the European examples, must have been made when metal tools were locally known, if not locally made. The only pendant that it has been possible to trace which imitates a metal type is an exact parallel to the Unival one; it is in the British Museum, and derives from Lukis's excavation of the long port-holed gallery of Kerlescan, near Carnac, a tomb which produced a handled Bronze Age pot, a beaker and a shallow bowl with groups of vertical applied ribs.<sup>5</sup>

A pumice pendant was found with Early Bronze Age pottery in a passage grave in St Mary's, Scilly, by Bonsor; who told Dr Hencken that he had found pumice also in chamber tombs in Southern Spain; it is in the British Museum, and is a small rounded lump pierced near one end. A similar pierced lump was found with 35 stone disc beads above floor level in the passage to the upper chamber of the two-storied tomb of Taversoe Tuick,

general distribution of the ware is westerly, and the Clacton site not really anomalous in that it is on a sea route. Specimens have recently been identified from Glenluce, including one strikingly Iberian one (R. B. K. Stevenson, *P.S.A.S.*, lxxx. 143).

<sup>1</sup> *P.S.A.S.*, lxxiii. 27; *P.P.S.*, 1947, 152.

<sup>2</sup> *P.S.A.S.*, lxix. p. 531. Reference is there made to another ball found outside the peristalith of an Anglesey tomb.

<sup>3</sup> Carn H. and Carn K. at Carrowkeel (R. A. S. Macalister, *P.R.I.A.*, xxix. C, p. 311).

<sup>4</sup> Jacquetta Hawkes, *J.R.S.A.I.*, lxxi. 1941, p. 130 ff.

<sup>5</sup> *Journ. Brit. Arch. Assoc.*, xxiv. 1868; Z. le Rouzic, *l'Anthropologie*, 1932, p. 246.

Rousay, Orkney. There is a long tradition of using pumice in the Hebrides, and the Unival pendant is likely to be of local manufacture. Lumps are still picked up on the shores for domestic use; it is common on Iron Age habitation sites; a lump used as a rubber was found at a low level in the chamber of the Clettraval tomb, and a number of lumps in the beaker level of the chamber tomb of Rudh' an Dunain, Skye. Geological examination of the Rudh' an Dunain specimens showed the material to be of West Indian origin.<sup>1</sup>

If the Unival pendant was worn round the neck, the body must have been laid with head to the entrance of the chamber, and was probably accompanied either by pot 52 or by pot 53. Since it imitates a flat axe or adze, it shows that metal tools were known in the Hebrides at latest when the later of these two pots, that is the beaker, was deposited. Two beaker burials in Mull were furnished with metal, one having a riveted knife-dagger, but none such is known in the Northern Hebrides; indeed the only early bronze from any source in the islands is a flat axe said to have been found in Glen Drynoch in Skye.

From the funerary levels in the chamber came two struck flakes of flint and nine probably struck flakes of quartz.<sup>2</sup>

#### *Structural Features of the Tomb.*

It is not proposed to add here to the literature of the typology of chamber tombs; indeed the moral which may be drawn is rather that to divorce the structure of tombs from their contents, and to study their structural typology in isolation, is to be deprecated as a source of error. For Unival is a tomb showing analogies to Clettraval in technique of construction, in design and in ritual such as to argue strongly that both were constructed and used by the same social group and at nearly the same time; yet, regarded typologically, one could be described as a passage grave in a short cairn and the other as a Clyde type segmented gallery in a long cairn. Nor can this antinomy be resolved by classifying the Hebrides as an area of mixed culture unless it can first be proved, as has not yet been done,<sup>3</sup> that passage graves and segmented galleries are really elements belonging to separate cultures.

In point of constructional technique the chamber ("Section I") of Clettraval resembles that of Unival in that both are built of orthostats tilted slightly backward against the cairn material behind them, their feet not being sunk into the earth; in contrast the remaining sections of Clettraval

<sup>1</sup> *P.S.A.S.*, lxvi. pp. 209-210. For a piece of pumice from the sandhill site of Dundrum, accompanied by pottery which Professor Estyn Evans thinks to approximate in date to the Rudh' an Dunain beaker, see *U.J.A.*, 1942, p. 12.

<sup>2</sup> I am indebted to Dr Charles McBurney for advice upon the quartz material.

<sup>3</sup> See in this regard Professor Childe's recent remarks in *Scotland before the Scots*, 98.

are built of orthostats tilted inward and supported by septal slabs. The façades of both tombs are built of orthostats tilted backward against the cairn, supported behind by built abutments and wedging slabs, and secured in front by blocks wedged between themselves and a tight paving of horizontally set slabs.<sup>1</sup> In point of design both tombs have an abnormal type of straight façade, slightly bowed out in the centre, and in both the peristalith follows a wedge-shaped plan, though at Cletraval the wedge is long and at Unival short. Both tombs have a cist in the south-west corner of the chamber and, in the light of the Unival evidence, this points to an identity in funerary ritual which is even more significant than the similarity in design. On the evidence of the pottery the tombs cannot be distant from one another in date.

There is one feature which Unival shares with Cletraval which calls for some further consideration. In each tomb the cairn is shallow, not covering the chamber or the peristalith, and it does not extend, except as a low retaining bank, beyond the peristalith. In each tomb moreover it is a more or less level platform, and banked up on the lower side of the site to make it so. This characteristic is probably shared by many other chamber tombs, and it points to the need to recognise that differences are as much to be expected in type of cairn as in shape of chamber. The older assumption that a substantial covering mound was of the essence of a chamber tomb sprung from the conception that these tombs were necessarily related to the earthen (unchambered) long barrow of Southern and Eastern England, which may be of quite different cultural origin.

In fact several sorts of cairn are to be recognised. There is first the artificial hill, itself plainly an object of ritual significance, which is most splendidly seen at New Grange. Even in these it is not to be assumed that the hill as it originally appeared was without feature, whether a visible façade and peristalith, or an outer ring of free-standing monoliths, and at Rudh' an Dunain chamber tomb in Skye it was possible to show that the conspicuous cairn had left visible the top, and probably the greater part, of the façade and peristalith.<sup>2</sup> Cairns which are artificial hills are not typical in the Mediterranean.<sup>3</sup> There are next those types of cairn which are architecturally planned: the stepped cairn, built in terraces each with

<sup>1</sup> In the report on Cletraval the paving, shown on the plan, was not interpreted as a structural requirement but as a path along the length of the façade. In the light of the much less wrecked façade at Unival it should certainly be regarded as structural.

<sup>2</sup> *P.S.A.S.*, lxxviii. 199, and pl. ii.

<sup>3</sup> Generalisation is difficult, but it would seem that in the Mediterranean the built tomb, like the rock-cut tomb, was typically excavated in a natural hill or cut down into a level ground surface, the overlying mound, if any, being the upcast from the excavation. Some Mycenaean *tholoi* (listed by Professor Childe, *Dawn*, 75 and fig. 39) had artificial mounds, if not very substantial ones, and in Malaga the great mound over the corbelled tomb of Romeral at Antequera is claimed by Dr Leisner to be artificial (*op. cit.*, 174), though Mr W. J. Hemp thought it almost certainly natural (*Ant. J.*, xiv, 410). There is no doubt that other of the large tombs of Southern Iberia, as many of the smaller ones, were excavated in the natural soil and had only slight mounds, if any.



a retaining wall, as at Wideford Hill, Orkney<sup>1</sup>; and the cairn which is a skin following the outline of the chamber, as in the Rousay tombs.<sup>2</sup> These have Mediterranean prototypes, the former at Los Millares in Almeria and at Arles in Provence<sup>3</sup>; the latter in the Sardinian giants' tombs and the Minorcan *navetas*. There are finally those shallow cairns in the nature of a platform around the exposed chamber which find a prototype in the shallow mound, presumably no more than the spread of the upcast, which overlie those Mediterranean rock-cut tombs which are on level sites.<sup>4</sup> There is a *prima facie* case for supposing that such cairns were widespread in North-west Europe in the fact that an immense number of chamber tombs have no substantial surviving mound; and Hebridean examples in which the feature can be demonstrated include not only Unival and Cletraval but also the tomb within the stone circle of Callernish in Lewis.<sup>5</sup>

It may be noted that it is no long step from these shallow cairns to the platform of boulders less than 2 feet in height within a megalithic kerb which constituted the cairn in the Neolithic enclosure at Lyles Hill, Belfast, a cairn which Professor Estyn Evans compares to the boulder platforms filling the forecourts of Ulster horned tombs<sup>6</sup>; nor to the boulder platform 1 foot 6 inches in height within the bank and orthostats of Stone Circle B at Loch Gur in Limerick.<sup>7</sup>

#### *Ritual.*

The most important aspect of these excavations is the ritual which they seem to disclose and the resemblances of this to Ægean ritual. The latter is best known to us from the sixteenth century onwards in the cemetery of rock-cut tombs at Mycenæ, from which Professor Wace had deduced a comprehensive formulation of the ritual observed.<sup>8</sup> Professor Wace's account will mainly be followed, but will be compared with the evidence from the chamber tombs of Crete, which commence slightly earlier, and with that from the still earlier cemetery of Vounous in Cyprus.<sup>9</sup> Practice naturally varied, not only with time and place, but also between contemporary tombs in the same cemetery; nevertheless there is a large common element for comparison with the Unival ritual.

<sup>1</sup> *R.C.A.M., Orkney*, No. 410. Petrie recognised this a century ago (*Arch.*, xxxiv, 124 ff.).

<sup>2</sup> *R.C.A.M., Orkney*, No. 573 ff.

<sup>3</sup> G. Leisner, *op. cit.*, pl. 85; W. J. Hemp, *Arch.*, lxxiii, 150.

<sup>4</sup> Oddly it has not been supposed that these tombs originally had great mounds, and the position of such a tomb as the Grotte des Fées at Arles is a guarantee that its slight mound has never been robbed.

<sup>5</sup> *R.C.A.M., Outer Hebrides*, No. 89. The tomb is an integral, or at least an integrated, part of the monument, and its relation to the stone setting shows it never to have had a substantial mound.

<sup>6</sup> *Quarterly Notes of the Belfast Museum*, March 1940, 4 ff.

<sup>7</sup> *P.P.S.*, 1946, 157.

<sup>8</sup> *Arch.*, lxxxii, 121 ff. Cf. also Perrson, *The Royal Tombs at Dendera*.

<sup>9</sup> A. Evans, *Arch.*, lix. and lxxv. (for the Zafer Papoura and Isopata cemeteries at Knossos); E. J. Forsdyke, *B.S.A.*, xxviii, 243 ff. (for the Mavro Spelio cemetery at Knossos); P. Dikaios, *Arch.*, lxxxviii, 1 ff. (for the Vounous cemetery in Cyprus).

Thus burial commonly took place in a specified part of the chamber. Sometimes this was a pit, which might be roofed, sometimes an alcove, sometimes a platform slightly raised from the floor, sometimes an area separated by a rock ridge from the rest of the chamber; commonly in Crete, but rarely on the mainland, a self-standing cist coffin of clay was used. The corpse was clothed and decorated with its ornaments, and was sometimes provided with its weapons or implements and regularly with a number of pots. The latter might be placed on the body, sometimes in the hand; or might be placed in a specified part of the chamber other than that reserved for the body, normally against the opposite wall. In Cyprus at least the pots might contain meat. The body was laid with the head slightly raised. The door of the tomb was walled up by the attendants as they left the chamber, and they may have poured a libation outside the closed door and broken the cup.

At some time before a second burial the door blocking was removed either in whole or as regards its upper part. Space for the second burial may sometimes have been found on the chamber floor beside the first burial, but commonly the earlier body was removed. Removal was sometimes effected with care to a pit in the dromos, or occasionally to a pit in the chamber floor, where the bones were packed in with sherds from pots of which the remaining parts survive on the chamber floor. Very frequently however the bones were piled up at the side of the chamber with the associated pots, or parts of them. Occasionally bones and sherds were merely thrown out into the dromos, in which process fragments might be dropped among the stones of the only partially removed door blocking. Grave goods were also deliberately removed from the tomb and taken away by the family. In some cases an earlier burial might be found covered with infiltrated silt; or soft rock fallen from the roof, and might not be removed; in some cases the body was perhaps deliberately covered with earth brought into the tomb. In these cases the later burial might be made at the resulting higher level, with the result that stratified burials are found; such seem to have occurred when the tomb remained in use for a long period (two or three centuries) and the number of burials was large (fifteen to twenty-one). At some stage, which Professor Waçe assumes to be on the opening of the tomb for the later burial, the chamber was "purified" with charcoal and incense burned on a brazier or on an incense burner, and burning charcoal might be carried into the tomb in long-handled scoops. In one case only, at Mycenæ, fire was laid on the chamber floor.

It will be seen that in this last respect the ritual differs from that inferred at Unival, where there was evidence that the bringing of charcoal into the tomb occurred at a determinate stage after a burial and not as a preliminary to a further burial. This exception may not be a real one. At the Tomb of the Double Axes at Knossos, in which there was only one burial, the upper

part of the original door blocking had been removed and later carefully rebuilt, presumably on the occasion of some ceremony performed in the chamber by the family, and a charcoal burner, not quite complete, was found in the tomb. In Tomb 518 at Mycenæ the presence of lamps, and other evidence, suggested to Professor Wace the possibility that at a stated time after the burial the relatives visited the tomb for the performance of rites connected with the dead. Moreover a number of the braziers and incense burners in the tombs have been found complete, thus pointing to their having been used in connection with the last burial in the tomb; in the L.M. 1 tomb at Isopata near Knossos (Tomb 5), in which only one skeleton was found, a complete brazier full of charcoal was found behind the head, the body lying between the brazier and the door. Accordingly, if we are correct in the inference made regarding the practice at Unival, there is no need to regard this as necessarily a departure from Mediterranean tradition.<sup>1</sup>

Reviewing the preceding evidence, there would seem to be ample ground for concluding that the Unival ritual derived from that of the Ægean area; and indeed, considering the distance over which the ritual had travelled, that the identity is remarkably close. The distance is spanned by many tombs having points of structural resemblance to those of the East Mediterranean but, so far as the writer knows, none of those excavated in Western Europe has yielded detailed evidence of the ritual observed; we merely know broadly that the tombs were used for successive inhumations accompanied by ornaments, personal equipment and pots, that earlier burials were removed to make way for later ones, and that fire was in some form introduced into the tomb.<sup>2</sup> In respect of this latter practice we have some more detailed evidence from Jersey, where vase supports in the tomb of La Hougue Bie show unmistakable marks of burning on their saucer-shaped tops, and presumably carried burning charcoal.<sup>3</sup>

Some light is thrown upon the distinction suggested above between the

<sup>1</sup> Other areas in which the cult of the dead is highly developed provide evidence of the mortuary ritual continuing for a considerable period after the death. For instance, in China, there were five sacrifices to the dead, the last occurring in the 27th month. After this family mourning ceased, but sacrifice was still made yearly on the anniversary of the death. These sacrifices were made, in the richer classes, at the altar in front of the grave mound. If it occurred that after death the soul regained possession of its body, and thus of human strength, it became a vampire dangerous to the living and drastic steps were taken—burning, frying, or beating the disinterred corpse—to drive the soul from the body (De Groot, *Religion of the Chinese*, 69-80).

<sup>2</sup> As of course in many tombs in the British Isles. For evidence of the piling up of bones by the chamber wall, reference may be made in particular to the Lanhill chamber *infra*, to Bryce's observations in the Clachaig and Torlin tombs in Arran (*P.S.A.S.*, xxxvi. 88), and to the evidence from the Rousay tombs summarised in *R.C.A.M., Orkney and Shetland*, i. 19. For cists in the chamber, *cf.* for Scotland, *P.S.A.S.*, lxi. 526, and for Ireland, Carn B at Carrowkeel (*P.R.I.A.*, C. 311). For the piling up of bones and the use of cists in Scandinavia, see C. A. Nordman, *Megalithic Tombs of Northern Europe*, 28. The best evidence for Iberia is from the Dolmen da Soto, Huelva (piling of bones) and Tomb G, Gandul, Seville (piling of pots), for which see Leisner, *op. cit.*, 225 and 205.

<sup>3</sup> Jacquetta Hawkes, *The Archaeology of the Channel Islands*, ii. 75 and 202.

earlier and later rituals at Unival by those Ægean tombs already mentioned in which many burials were made over a long period, and the later burials merely laid on the silted-up floor of the chamber above the remains of earlier ones. For the East Mediterranean tombs are commonly, and probably rightly, regarded as family sepulchres, and the later burials in question (accompanied by later types of pottery) must be assumed to have been interred according to a ritual which is no more than a degeneration of that followed in the earlier burials. It is likely that the same is true of the later burials at Unival, and that the distinction between the two rituals there is the result of changes brought about in the culture by the passage of time, and not of the introduction into the Hebrides of a radically new culture. This accords with the consideration that it is inherently improbable that a radical change in culture could be compatible with the continuance of burial in the same tomb.

It has been mentioned that the later burials at Unival must have been effected by removing a part of the roof of the chamber, and it is likely that this practice was more common than has been suspected. At Alapraia a rock-cut tomb was provided with a hole in the roof through which the later burials in the chamber were made, and others of the rock-cut tombs of the Tagus estuary were probably similarly provided.<sup>1</sup> The tiny Lanhill chamber, which contained the piled-up remains of seven earlier burials and an eighth intact skeleton, would have been more easily entered by the funeral party as the excavators entered it, namely, by the removal of a broken piece of the capstone; and we may believe that they in fact did so, despite the experimental success achieved by Mr Keiller and Professor Piggott in manipulating a dummy corpse through a model of the extremely exiguous porthole entrance of the chamber.<sup>2</sup> In the light of Ægean precedent such a method of entry must be regarded as a degeneration in funerary ritual, and at Unival there is no ground for supposing that it was adopted so long as burial in the cist in accordance with the earlier ritual was still practised. It may however have been in fairly common use in Western Europe wherever porthole or other exiguous openings occur, for these seem much less well designed for the carrying of the dead into the tomb than for preventing the ghost from following the attendants as they left the chamber. That similar devices have been held effective for such a purpose is amply evidenced by modern examples.

#### *Dating.*

It is perilous at the present time to offer any comments on the dating of a chamber tomb. It seems right to point out, however, that the ritual identity argued above with Ægean practice is with tombs of which the

<sup>1</sup> E. Jalhay and A. do Paço, *A Gruta II da Necropole de Alapraia, Anais iv.* (Lisbon, 1941), 112 and 137.

<sup>2</sup> *P.P.S.*, 1938, 124 ff.

greater number are not earlier than the sixteenth, or at any rate the seventeenth, century B.C.; and that, if the argument from identity of ritual is held to have weight, it would be difficult to date Unival to any earlier period. It will be recollected that a mid-second millennium date has been inferred for pot 51 and its Wessex and Orkney analogues on grounds of just such contacts with the Ægean as are implied by the identity of ritual. The number of burials preceding that with pot 51 was not such as to suggest use of the tomb for more than perhaps a century, and the sequence of development shown in the Neolithic pottery has been argued from the Eilean an Tighe evidence to be unlikely to have been spread over any longer period. Nor does the sequence at Rinyo suggest any substantially greater time span, for there at the lowest levels there was plain Neolithic pottery and Rinyo I ware of the type of pot 51 (whether contemporaneously or successively was not evidenced), and these were followed by relief decorated wares (Rinyo II) and by a beaker, while the whole life of this tiny settlement cannot with likelihood be stretched over more than two, or at the most three, centuries.

If such conclusions were permissible many antinomies would be resolved, both old and more recent: for example, the structural analogies between tholos tombs in North-west Europe and those in the Ægean; the identity of pendants from Irish passage graves with pendants from "Wessex Culture" tombs; the primacy of cremation in Irish horned cairns, and of cremation and food-vessels in other Irish chamber tombs; the occurrence in Breton chamber tombs of vase supports related to "Wessex Culture" pottery, and in one such tomb of segmented faience beads; the Bygholm find in a pot of earliest passage grave type of a copper hoard containing a dagger with mid-rib on one face which is similar in form to, and almost identical in chemical composition with, one from a corbelled tomb at Alcalá in Algarve.<sup>1</sup> All this would become clearer if the chamber tombs were an incident of a brief civilised period in the history of a barbarous North-west Europe: an episode in which Mediterranean merchants, or their semi-Mediterraneanised trade correspondents, established trading settlements on the islands and promontories of the Atlantic coasts to organise the supply by the natives of their copper, gold, callais, greenstone and amber; and from these settlements diffused in Britain a changing succession of pottery styles, which displaced the crude native Windmill Hill pottery and developed into the local wares of Beacharra and Unstan, of Rinyo and Skara Brae, and the early types of incense cup and food-vessel.<sup>2</sup> All this would be clearer; but we

<sup>1</sup> These recent chemical analyses are noted by Professor Childe in *Institute of Archaeology, Fourth Report*, 1948, 57. For the not less critical Gilchorn find see Appendix III below.

<sup>2</sup> In dating Windmill Hill pottery, however, account must now be taken of the fact that the supposedly equally early Cortaillod I pottery has been shown to be decorated with patterns cut out in birch bark and stuck on with pitch (see Dr E. Vogt's forthcoming paper in *P.P.S.*, 1949). These patterns are strikingly like patterns from Villafrati and Anghelu Rujù.

should have to abandon more than we have yet abandoned of the traditional March of the Ages, each Age in turn moving uniformly forward over a broad front in space and through a long sweep in time—Neolithic and chamber tombs, Early Bronze and beakers, Middle Bronze and food-vessels—and the readjustment would not be easy.

APPENDIX I.

REPORT ON HUMAN REMAINS. By Prof. A. E. J. CAVE,  
St. Bartholomew's Hospital Medical School.

These remains are extremely fragmentary, brittle, and much calcined, and have, in many instances, suffered distortion from fire heat. Only a limited number of the very numerous fragments can be unquestionably identified as human remains; the humanity of many others is merely inferred from their association, though doubtless correctly. With the possible exception of some rib fragments (reserved for Dr Jackson's opinion) no obvious animal bones occur in the material. Should certain of these rib pieces prove not to be animal, then they must represent another and younger individual than the one forming the main content of this tomb. (*Note.*—Dr Wilfred Jackson confirmed in subsequent correspondence that these bones were not animal but belonging to a young human individual, and Dr Cave put the age at under twenty-one.—L. S.)

- B. 0. Impossible to determine: some burnt fragments of human skull.
- B, 1. All burnt, fissured and distorted, fragments of vertebræ, ribs, skull, scapula.
- B, 2. Fragments—impossible of identification.
- B, 3 (1, 2, 3). See below.
- B, 3 (4). Indeterminate fragment.
- B, 3 (5). Rib fragment. ? human, ? animal.
- B, 3 (6). Indeterminate fragments.
- B, 4. A presumably human chip of bone.
- B, 5. Long bone chip. ? human, ? animal.
- B, 3 (1, 2, 3). All part of one and same individual, hopelessly disintegrated. Female, adult, over twenty-five years of age. Of small stature and delicate build: Mandible with square-cut and tall ascending ramus, pointed chin; face probably straight or nearly so. Skull thick, and *probably* round in contour. No evidence of ante-mortem disease or injury.

Parts recognisable: cranial vault, mandibular and maxillary fragments, cervical and dorso-lumbar vertebræ, part of scapula, cranial base (occiput,

petrous temporals, sphenoid), malar bone, first ribs and parts of many others, metacarpals, carpals, chip of astragalus.

All bones much calcined. Charcoal admixed. (*Note.*—Dr Cave confirmed verbally that the degree of calcination was not consistent with cremation.—L. S.)

## APPENDIX II.

### *Classification of Finds.*

Position is indicated by rectangular co-ordinates as shown upon the drawings, the plane  $z=0$  being 21 feet 3 inches below the top of the tall western orthostat in the chamber (C4). In the original excavations, however, a plane 20 feet above this was used, and a white paint line marked upon C4 where this cut the orthostat. Vertical measurements were made downwards from this plane, and accordingly the vertical positions marked upon all finds require to be subtracted from 20 feet to bring them into correspondence with the vertical positions indicated in this report.

The orthostats are marked F1, F2, and so on, and intervening panels of masonry are referred to as F1-2, F2-3, and so on. The finds are normally classified by area and stratum. The areas in the chamber are shown in fig. 5; those in the excavated parts exterior to the façade and peristalith are identified by the orthostat or intervening panel of masonry opposite to which (in a line at right angles to its face) they lay; the parts excavated within the façade and peristalith were the house, which is referred to as Area H, and the storehouse, in which there were no finds. The strata are: 0,  $z=0-1$ ; 1,  $z=1-2$ ; and so on. Thus A1, 0 indicates a position in Area A1 and Stratum 0.

## APPENDIX III.

### *Chronology of the Wessex Culture.*

Since Professor Piggott published his famous paper on the Early Bronze Age in Wessex <sup>1</sup> a number of studies have appeared, but it has been generally accepted that the group of barrows which were then identified provide a fixed point, and indeed the only fixed point, in the history of the second millennium in Britain. In the paper the assemblage of funerary gifts was traced to its multifarious sources: amber and battle-axes to the Baltic; pins of Aunjeticz types, and perhaps amber and shale cups, to Central Europe; crescentic necklaces and cushion mace-heads to the food-vessel culture of Northern Britain; gold ornaments to Ireland; and to Brittany.

<sup>1</sup> *P.P.S.*, 1938, 52 ff.

not only square-tanged arrow-heads and grooved and midrib daggers of ultimate Mediterranean origin—two with gold-studded hafts—but also grape cups, Aldbourne cups of vase support derivation, and four more or less close imitations of vase supports themselves. In addition there were many segmented faience beads, such as occur widely, though more often in bone or shell (encrinites) than in faience, in Iberia, Languedoc and Brittany; these beads however were judged to be actual Egyptian exports of about 1400.<sup>1</sup> Finally there was the gold-mounted amber disc recently re-studied by Professor Childe and mentioned above; this so closely resembles a disc from a L.M. II tomb at Knossos that the latter must be an actual import from the British Isles.<sup>2</sup> This must date to about 1450 B.C., and confirms the other less precise evidences assembled in the paper of trade between Britain and the Ægean in the sixteenth and fifteenth centuries.

Professor Piggott attributed this group of tombs to an immigrant aristocracy coming from Brittany, and, despite the possibility suggested by Professor Childe that the movement might be reversed, the pottery seems to provide good ground for assuming some movement of people thence. Whether the immigrants constituted an aristocracy, and whether the barrows constituted a "Wessex Culture", may be more doubtful; the assemblage of grave goods suggests rather that Wessex at this period was a centre of North-west European water-borne trade such as in historic times London was to become. It does not seem to have been noticed that the Bristol and Salisbury Avons were navigable by canoes to the margins of Salisbury Plain, and that primitive trade sought ports on the verge of habitable lands where commercial interchange could take place, and was uninterested in the sea-coast as such. The coasts between Bideford and Mount's Bay are by all reasonable means to be avoided by seamen, and the two Avons—to mention no other rivers—are well placed to meet the requirements of Cross-Channel, Up-Channel, Bristol Channel and Irish Sea trade, and provided excellent port facilities above Bradford and Salisbury. In the absence of pack animals, of which there is no evidence in the second millennium, trade was inevitably canoe-borne and, save by water, it was no more practicable for Wessex to trade in stone axes with Cumberland or North Wales than to trade in bluestone megaliths with Prescelly; the goods would not pay for their freight.<sup>3</sup> There is therefore a case for regarding the rich grave goods in the Wessex tombs as a trading phenomenon rather than as in themselves constituting a culture, and this explanation accords

<sup>1</sup> *Arch.*, lxxxv. 203 ff. While these particular beads may be Egyptian exports, the existence of other faience beads which cannot be paralleled in Egypt seems to show that there was a secondary manufacture in Britain, though perhaps at a later date.

<sup>2</sup> V. G. Childe, *Festschrift für Otto Tschumi*, 70.

<sup>3</sup> The *minimum* price to the customer of a pack-load of goods imported on the human back is the cost of the food consumed by the packman on his journey. Only trinkets of high value can be so imported economically over distances exceeding a few days' journey.



better with the fact that the goods are found, some not less plentifully, on trade routes remote from Wessex.<sup>1</sup>

Professor Piggott dates the "Wessex Culture," *i.e.* the grave goods mentioned above and the barrows—typically bell and disc barrows—in which they are found, to 1700-1400 B.C. The earlier date is adopted to accord with the conventional date of the advent of the beaker cultures *c.* 1800 B.C., and is accordingly based on no specific evidence<sup>2</sup>; it is assumed that there were two preceding beaker cultures, marked respectively by B1 and A beakers. It has recently been argued by Dr Stone that the beaker cultures in Wessex were evanescent happenings, representing little more than the passage of nomads moving to the Highland Zone; it is even questioned whether these "ever returned on their tracks."<sup>3</sup> Dr Stone is able to point to the scarcity of both B and A beakers in Wessex and, having regard to the known density of population there, his argument has some force. Moreover, south-west of Wessex, where there is substantially no beaker culture, there are "Wessex Culture" phenomena: bell barrows, daggers, shale cups and also segmented beads of bone and faience.<sup>4</sup> The history of Devon and Cornwall as recorded in structural remains is not different from that of Wessex and there is certainly a case for arguing that, in those regions of Britain dominated by Atlantic route cultures, the beaker users were absorbed without substantially altering the cultures of the pre-existing communities.<sup>5</sup>

<sup>1</sup> For example, on the trade routes available to water transport across Scotland, *i.e.* Clyde-Forth, Clyde-Tay and the Great Glen, and on trading posts on the approaches to these routes from Ireland, The "dagger graves" with midrib and grooved daggers are listed in Professor Childe's *Scotland before the Scots*, App. VIB; to which add the grave recorded in *P.S.A.S.*, xii, 456. The sites are: Glenluce, near the Mull of Galloway; Blackwater Foot, in Arran; Carluke, on the Clyde above Glasgow; Auchterhouse, near Dundee; and Gilchorn, near Arbroath. It may, moreover, be noted particularly that the dagger from the great Arran cairn had a ribbed pommel-mounting of gold of evidently Irish origin and identical with the mounting of the grooved dagger accompanying a Type E food-vessel in the tomb on Topped Mountain, in Fermanagh. The Gilchorn cairn produced, not only a midrib and a grooved dagger from its central pit (or cist) grave, but also a midrib dagger with unsymmetrical notches for binding to the haft. The notched dagger is a distinctive South Iberian type; it has been found in the Harristown cairn in Co. Waterford (*J.R.S.A.I.*, lxxi, 139, fig. 5) and not elsewhere in the British Isles. The Gilchorn specimen accompanied an overhanging rim urn, and another urn in the cairn was accompanied by an incense cup with characteristically Iberian decoration of continuous lines of zigzags set vertically. The Gilchorn find seems precisely as significant for trade with Spain, and for chronology, as the much discussed Bygholm find mentioned on p. 36 above.

<sup>2</sup> Cf. App. IX, "Absolute Chronology," in Professor Childe's *Scotland before the Scots*. Regarding the Wessex Culture, it is there argued that it "may go back even to 1600."

<sup>3</sup> *Ant. J.*, July-Oct. 1948, 152.

<sup>4</sup> In Exeter Museum (information kindly given by Lady Fox) and for Cornwall, H. O'N. Hencken, *Archaeology of Cornwall*, 74.

<sup>5</sup> As Dr Leisner has argued to have been the case with the beaker users in Iberia (*op. cit.*, 454, 573). Dr Leisner regards the classical beaker with alternate plain and hatched zones as sea-borne and intrusive from some unidentified source further east in the Mediterranean. His argument regarding the absorption of the beaker users extends however to Andalusia, where the classical beaker hardly occurs and the "beakers" in question are predominantly not of beaker shape and decorated in the style derived from the Palmella pottery of the Tagus Estuary. The Palmella style of decoration, which is applied to a wide range of vessels and plates, presumably is intrusive on the Guadalquivir; and burials accompanied

In 1943 Sir Cyril Fox, discussing the beaker cultures of the West, showed them to overlap with the Wessex Culture, and dated them from 1800 to 1500 as against the 1700 to 1400 bracket of the latter.<sup>1</sup> Some such overlap is indeed suggested by Professor Piggott's data, for his graves include imports from the northern Food-Vessel Culture, which, in Scotland at least, partially synchronised with beakers.<sup>2</sup> And at Fargo Plantation in Wessex itself Dr Stone has shown that an Irish food-vessel and an A beaker were probably contemporaneous deposits in the same tomb.<sup>3</sup>

Some importance as a chronological horizon may attach to the introduction of the custom of unurned cremation burial. Such burials occur in Irish chamber tombs, and Sir Cyril Fox has shown in the paper cited that in Britain they may be accompanied by pygmy vessels, presumably related to the Wessex Culture cups, which appear independently of, and earlier than, cinerary urns, and indeed often with inhumations; and further that the overhanging rim urn, which may occur as a vessel accessory to an inhumation, may be decorated in beaker technique. Important light is thrown on the introduction of unurned cremation burial by Mr Atkinson's brilliant series of excavations of "henge" monuments at Dorchester, Oxon.<sup>4</sup> While the classification of these ditched and banked enclosures is still an open question, and some seem to be associated with A beakers, it has been shown that some of the single-entrance, and generally smaller, enclosures were thickly peppered with unurned cremations, particularly in and near the ditch. They were further distinguished by Woodhenge, or sometimes Windmill Hill or Peterborough, pottery, and by long bone pins; these are related by Mr Atkinson to the similar pins of Skara Brae, and it is hard to believe that they are not also related to the long pins of the Irish chamber tombs, which in turn are generally held to be related to the pins found in tombs and habitation sites in Iberia.<sup>5</sup> It is to be noted, moreover, that the bank, ditch and

by pots in this style may represent an absorbed element in the population, but not the *same* element as is represented by the classical beaker in South-east Spain. In the Tagus Estuary, where the two quite distinct types of pottery both occur, their mutual relations are still unknown.

<sup>1</sup> *Arch.*, lxxxix. 89 ff.

<sup>2</sup> Cf. V. G. Childe, *Prehistoric Communities*, 131. It is quite accordant that in an easterly region such as Yorkshire the food-vessels should be later than the beakers wherever the two cultures appear in mutual contact; and a similar time sequence may be expected in inland regions such as the Trent and Thames valleys which provide river ports open to North Sea shipping.

<sup>3</sup> *Wills. Arch. Mag.*, xlviii. 363.

<sup>4</sup> Reported verbally to the Prehistoric Society; written report forthcoming from the Ashmolean Museum.

<sup>5</sup> The British series of long bone pins is fairly closely in parallel with the South Iberian series: for which see Leisner, *op. cit.*, 451 ff., and tomb inventory and plates *passim*. In both areas the majority of the pins have plain round shafts without significant enlargement at the head. Of the specialised types with enlarged heads, that with plain cylindrical head is the most common in South Iberia; since the heads were frequently made separately and fitted as handles over a bone shaft or a copper awl, this type may be an awl rather than a pin. There are no British analogues. The type with flat spatulate head occurs both in Spain and Portugal; in Britain it occurs in the Bateman collection from Staffordshire and three times at Skara Brae. The well known type with segmented (transversely grooved) head belongs essentially to Western Iberia; it occurs in Ireland in a cremation cist in Galway and also,

Aubrey holes at Stonehenge form such a henge monument and that they contained similarly numerous unurned cremations, a fragment of Woodhenge pottery (with beaker at a higher level), long bone pins, a cushion mace-head and the vase support already mentioned. It seems at least probable, moreover, that the same burial customs can be traced to Brittany: the Er-Lannic enclosures, which produced so many vase supports, were thickly peppered with unurned cremations each protected by a few slabs; rectangular enclosures such as Manio, covered by a low mound with standing-stones in or close to them, produced plain and (apparently) Chassey type pottery and were thickly scattered, both within the mound and near it, with similarly protected unurned cremations.<sup>1</sup>

If Mr Brailsford is right in his interpretation of the Sheep Down excavation,<sup>2</sup> a further class of such cremation enclosures is to be found in Wessex itself in "pond barrows" producing food-vessels and overhanging rim urns. If so, and if we adopt the established conventions, we shall have to suppose the existence within Wessex of a tribe of persistent cremators who, throughout a period extending from the "Neolithic" to the "Middle Bronze Age," adopted in succession, and from different sources, a long series of pottery types, but continued to bury their dead in accordance with an unurned cremation ritual. The history of North-west Europe in the first millennium A.D. shows however that tribal groups are more surely identified by their domestic artifacts than by such more infectious practices as burial rites,

though in an abnormal form with wide grooves, at Skara Brae. The Tagus Estuary produces also a diversity of elaborately worked heads (*cf.* particularly San Pedro, *Actas y Memorias*, xx, 1945, 38) but most belong to small pins; among large pins the established comparison with those from the Irish tombs, though no doubt a real one, is not very close. A specifically British variant, which is only common at Skara Brae but occurs once each at Crosby Garrett barrow in Westmorland, at Stonehenge and at Windmill Hill, has a lug worked on the shaft and perforated. The principal associations of the long pin in the British Isles are: Ireland, in the passage graves and the Galway cist mentioned above with cremations and food-vessels, but also in a recent find with a round-bottomed bowl (information from Professor O'Riordain); Orkney, with Rinyo I and II wares at Skara Brae and also (an unpierced-lug pin) in the chamber tomb of Quoyness with stone objects of distinctive Skara Brae type; Man (an Irish mushroom-headed pin) with cremations and Glencrutchery ware; North England, with simultaneous inhumations and cremations and a plain neolithic bowl at Duggleby Howe, with inhumations and cremations at Crosby Garrett, and with cremations and a food-vessel at Garton Slack, barrow 112; in Anglesey, with groove-decorated neolithic pottery at Llygwy; in Southern England, at Dorchester and Stonehenge with the associations stated above, and at Windmill Hill in a Peterborough-Beaker horizon. The Iberian long pins are attributed by Dr Leisner to the Full Copper Age and occur in chamber tombs with both inhumations and burnt bones. Despite the differences indicated above, and the present limitations in our knowledge, the more or less simultaneous appearance (and subsequent disappearance) in Iberia and the British Isles of this family of long bone pins in habitation sites and in tombs showing both inhumation and cremation is not likely to be fortuitous and argues a South-western derivation for the British Isles family.

<sup>1</sup> *L'Anthropologie*, xliii, 225 ff., and xliv, 487. Manio is in Morbihan, but a number of such enclosures occur also in Finistère (P. du Chatellier, *Les Epoques Préhistoriques en Finistère*, 20, 23, 182 and pl. vi). Pen-ar-Ménez and Kervilloc, Treffiat, contained rectangular enclosures apparently up to 60 feet by 30 feet with many cremations in small cists against the walls and with neighbouring standing stones. The finds included round bottomed plain pots, maces and pendants and also (relying on *ibid.*, *La Poterie . . . en Armorique*, pl. ix, 1) beaker fragments.

<sup>2</sup> *Arch. News Letter*, April 1949, 12, 13.

and the suspicion is aroused that the Wessex pottery sequence is not one in time; that the pottery types were to a material extent contemporary and the styles of different tribal (or caste) groups; and that the practice of unurned cremation gradually spread among these different groups to the ultimate exclusion among them of inhumation in chamber tombs, cists and earth graves under barrows.

In the light of these conflicting considerations it may be well to look again at Brittany, the suggested source of Professor Piggott's culture, and to study the Breton sequence already mentioned, which has been acutely analysed by Mrs Hawkes in its Jersey manifestations. The earlier culture at the stratified site of the Pinnacle<sup>1</sup> included round-bottomed carinated pots with upstanding lugs, and also pots decorated with straight or festooned lines of jabs, panels of punctuations and lines of bosses. This decorated ware is clearly of Chassey type and related to the vase support, which itself occurs in Jersey though there are no certain examples at the Pinnacle. The later culture on the site included coarse straight-sided or barrel jars with relief decoration in straight or curved finger-tipped cordons, beaker ware, Grand Pressigny flint, a segmental pendant which parallels that from Skara Brae, and a copper axe with expanding edge. This accords with the sequence: Neolithic and Rinyo I; Rinyo II and beaker, which we have found in the Hebrides and Orkneys—even to the axe, which appears at Unival as an axe pendant. There is no similarly reliable analysis for Brittany itself and, though we know that in one tomb (Conguel) beaker ware was stratified over Beacharra ware, we can broadly say no more than that analogues to the British pottery styles discussed above all occur in the chamber tombs. Nor are other Wessex products absent from the chamber tombs, which have produced spacing beads belonging to a crescentic necklace of Food-Vessel Culture type, a jet spacing-bead and, as already stated, a segmented faience bead.<sup>2</sup> The grooved and midrib daggers on the other hand, and the square-tanged arrow-heads, occur in sub-megalithic or corbelled cists, in which they are unaccompanied by pottery; and, as these show a distribution generally contrasting with that of the chamber tombs, they must represent a different tribal group. They are not necessarily to be assumed later in time, since midrib daggers occur in Iberian chamber tombs which are presumably contemporary with those of Brittany.

Most of these Breton types, and in particular the Breton analogues of the Aldbourne and grape cups of Wessex, can be traced further south along the Atlantic route; but it does not seem to have been noticed that in Southern Spain and the Tagus Estuary a series of pygmy vessels, or pyxides,

<sup>1</sup> Jacquetta Hawkes, *Archæology of the Channel Islands*, ii. 72 ff., 88 ff. and 160 ff.

<sup>2</sup> Amber spacing-beads in the Lesconil group of tombs (*American Anthropologist*, xxxii. 89); faience bead in Parc-er-guren tomb (*l'Anthropologie*, xliv, 507, fig. 19); jet spacing-bead from Kerguevarec (*P.P.S.*, 1939, 193).

can be identified which parallels the series of early incense cups in wider areas of Britain. These Iberian vessels, which are characteristic of the richer tombs, may be of stone, bone or ivory as well as of pottery and, in marked contrast to the other vessels of the South Iberian tombs, they are frequently decorated. There are two characteristic shapes: one is squat biconical like a bird's-nest pyxis, and the other is straight-sided, either vertical or sloping slightly inwards or outwards; the bottoms are slightly rounded or flat; the rims are occasionally developed. The decoration, which commonly covers the pot and may extend to the bottom, is by deeply grooved, incised, or (rarely) painted lines; dots (exceptionally in paint); stabs; and bosses. Apart from rare *oculi* and other magical devices, the design elements used are: widely spaced cross hatching; continuous zigzag lines set parallel to one another and at some distance apart, and running either horizontally or vertically; large triangles alternately plain and filled with dots or stabs; parallel rows of close-set bosses. These design elements (apart from the last) are sometimes arranged in metopes and are commonly set off by groups of horizontal lines above and below; their effect is a distinctively open pattern in contrast to the close decorative styles of Palmella and the beakers. Some of these small pots had a lid, some a rebate for a lid and some two or more holes in the side to take a string to secure a lid. It is in these last respects that comparison with the early British incense cups is the most obvious, but closer study shows that similarities in shape and in the distinctive style of open pattern are the more decisive. These similarities are in just those characteristics of shape and pattern which the incense cups cannot have inherited from British neolithic, beaker and food-vessel pottery—the consideration which has already led to the acceptance of the Atlantic route derivation of the Aldbourne and grape cups. The significant comparisons are naturally with the early incense cups, such as are found normally with inhumations and unurned cremations, rather than with the types developed subsequently within Britain, and commonly found inside cinerary urns, at a date when movement along the Atlantic route had ceased.<sup>1</sup> Comparison may also be made with the Folkton drums, which are presumably lidded pyxides carved in the solid.<sup>2</sup> It is not necessarily to be inferred from these comparisons that our early

<sup>1</sup> As examples of the two series compare Los Millares, Tombs 5, 8, 9, 21, 39, 47, Loma de las Eras, Los Castellones, Loma de Huéchar, Blanquizaras and the silos of Carlero (Leisner, *op. cit.*, pls. 13, 16, 19, 22-25, 29, 37, 153, 155, 159, 160) with the following: Wessex and Devon, Abercromby, ii, figs. 235, 236, 240, 249, and the grape cups shown in Professor Piggott's paper; South Wales, *P.P.S.*, 1938, 117, fig. 7 (with decorated bottom and red filling); Lancashire, *Arch.*, ix, 191, pl. ix (round bottomed cup with inhumation); Yorkshire, Abercromby, ii, figs. 112b, 308; Ayrshire, *P.S.A.S.*, lxxii, 241 ff., figs. 7, 9 (two cups, one with decorated round bottom and omphalos, together with an overhanging rim urn, in a cremation enclosure); Angus, the Gilchorn cup mentioned on p. 40 *n.* 1 above; Hebrides, Unival pot 51; Orkneys, *P.S.A.S.* iii, 485.

<sup>2</sup> Dr Leisner compares them with the stone jar with lid rebate from Los Millares, Tomb 40 (*op. cit.*, 479, *n.* 1).

incense cups are direct derivatives of the Spanish series of vessels; indeed it is rather more probable that both series originate in a common Mediterranean source.<sup>1</sup> Of the Iberian vessels some are plainly derivative, though very likely at second hand through Central Mediterranean settlements, from the pottery and stone pyxides decorated in the incised geometrical style with white or red filling which was revived in Crete in M.M.I. times.<sup>2</sup>

Having called attention to these discussions subsequent to, and largely stimulated by, Professor Piggott's paper, it is the purpose of this note only to suggest one very broad conclusion. It does not now seem likely that success would attend an attempt to arrange the pottery types of Wessex in a series in time, each type representing a culture which, in orderly manner and after a decent interval, displaced its predecessor. It seems more probable that the new synthesis when it is achieved will contemplate rather cultures flourishing contemporaneously within the area, and even in close proximity. Thus, in the case of the beakers, it has become less than ever plausible to suppose that a handful of A beaker users swept over Wessex from the east, extinguishing existing cultures, B beaker or otherwise, as they went. Such devastating tribal movements are more common in archaeological literature than in real life, and the evidence for Wessex does not require us to assume them. On the contrary, as has been said, the data available for Western Britain much more strongly suggest that eastern (and relatively backward, beaker users were absorbed into the pre-existing societies with little disturbance to the pre-existing cultures; and probably in quite a gradual manner over several generations. Thus introduced, their pottery came to be adopted in the West for use even in the family graves.

No different explanation is required for other cultural elements. It has been suggested that the phenomena comprehended in the "Wessex Culture" point to trade rather than to conquest; and primitive trade very commonly leads to settlement among the tribes the traders visit. There is no need to suppose that the Breton "Chassey ware people," or the Breton "dagger grave people," displaced an already established "B1 beaker people" when members of these several tribes moved into Wessex. It may be that the B1 beaker movement reached Wessex (from whatever source) the earliest, though if the source was Brittany, as Professor Piggott argues, it would be difficult to deduce such a priority from the Breton evidence<sup>3</sup>; but, whether so or not, the several drifts of population which are implied may quite well have been proceeding simultaneously, and in amity, and from different parts of Brittany or Northern France. Within the same period those movements may have been occurring which carried up the Atlantic route the pottery

<sup>1</sup> On navigational grounds shipping movements from the Mediterranean to Britain by the Aude-Garonne river route are more readily to be presumed than movements from the Tagus round Cape Finistère in Galicia.

<sup>2</sup> A. Evans, *Palace of Minos*, iv, 87 ff., and i, 177 ff.

<sup>3</sup> Professor Piggott has recognised the difficulty (*P.P.S.*, 1938, 95).

traditions which produced in the Hebrides and Orkneys the wares which we have called Rinyo I and II; over wide areas of Britain and Ireland the early food-vessels and incense cups; and in Wessex and the South the types we have rather vaguely included in Woodhenge ware. And at widely varying dates the tribes in question may have absorbed beaker users. During the whole period parties of traders and settlers were carrying up the Atlantic route their several native burial practices: inhumation in chamber tombs, inhumation in closed cists, unurned cremation in chamber tombs and unurned cremation in henge enclosures.

Such a picture supposes that the episode in the second millennium history of North-west Europe, in which trading relations were open with the Mediterranean, can be confined within two or three centuries: be it noted no insubstantial period. Professor Piggott's bracket of 1700-1400 B.C.; but brought down a century to 1600-1300 B.C., could comprehend, not only his "Wessex Culture" phenomena, but also the other incidents of Atlantic route trade, not excluding the introduction of the chamber tomb cult and the displacement by Beacharra and Unstan ware of the native Windmill Hill pottery. It is to be borne in mind that all the Continental analogues of the pottery types from which we argue occur on the Continent in chamber tombs, and, though we have reason to question the Continental evidence as insufficiently distinguishing between different strata, the Jersey analysis quoted above supports the assumption of contemporaneity there of types which we have sought to arrange in a spaced time sequence here. The Iberian evidence, though lacking the confirmation of stratigraphy, yields a like conclusion. In Central Europe it is now recognised that Reinecke's periods A2 and B were contemporary and not successive, and each alike can be dated back to c. 1450 B.C. but—on specific evidence—no further.<sup>1</sup> There is, moreover, the broad consideration that throughout Western Europe from Almeria and Algarve to Scandinavia the consensus of evidence is that the chamber tomb cult was a relatively later episode in the prehistory of those lands than we have been prepared to admit it to be in Britain; and, it may be added, one correspondingly more consonant with the Ægean evidence, if the cult was the result of trading voyages thence.

The time is ripe for reassessment. The writing down of chronologies in the Near East is being followed in the Central and Western Mediterranean. Dr Bernabo Brea is understood to equate the beginning of the Siculan I period with Middle Minoan I, and therefore to bring the earliest chamber tombs within the second millennium. Dr Leisner's analysis of the Iberian material justifies no earlier date for the chamber tombs there,<sup>2</sup> and it would

<sup>1</sup> Reinecke B from the spacing bead in the Kakovatos tomb; Reinecke A2 from the Aunjeticz pins in the Wessex Culture graves. (V. G. Childe in *Festschrift für Otto Tschumi*, 70 ff.).

<sup>2</sup> *Op. cit.*, 586 ff., reliance not being placed on the tentative derivation of the two segmental bone objects from Los Millares, Tombs 1 and 7, from Egyptian copper axes to be dated not later than 2080 B.C.

seem on general grounds that they must be later. For trading settlements only follow trading voyages, and Central Mediterranean colonies would hardly attempt trading ventures in remote Iberia until they were themselves mature. The exploitation of the Atlantic route, which can hardly have preceded in less than three stages, South France, Brittany and Western Britain, would at each stage have involved a pause for the establishment and maturing of each new colony. It is surprising indeed that a chain of trading settlements can be shown to have been established between Western Britain and the Ægean by the mid-fifteenth century. If we seek economy in surprise, we should forbear, so long as established evidence does not require it of us, to presume a date before the sixteenth century for the beginning of our relations with the Mediterranean and the building of our first chamber tomb.

#### APPENDIX IV.

##### *The Chamber Tomb of Cletraval.*

When the chamber tomb of Cletraval in North Uist was excavated, the peristalith was traced for a distance of 30 feet in a straight line from the southern end of the tomb façade (*P.S.A.S.*, lxxix. 492-4, and Pl. I). While it was suggested that the tomb enclosure was wedge-shaped, trenches dug to the south and south-west of the "dun" which had been built to the west of the tomb chamber failed to identify the further course of the peristalith, and to the north of the tomb peat diggings rendered excavation useless.

The "dun" has now been excavated and found to be a farmhouse of the aisled round-house culture lying with numerous outbuildings within a farmyard wall. The pottery evidence shows this to have been built in the later part of the first century B.C. by immigrants from South-west Britain or North-west Gaul, who also built the "wheelhouses" of the Vallay group excavated by the late Dr Erskine Beveridge. The excavation of the house is reported in the *Proceedings of the Prehistoric Society* for 1948 in a paper which deals with the aisled round-house culture as a whole, and the site plan in fig. 8 is reproduced by permission from those *Proceedings*. It will be seen that a further stretch of the peristalith was identified to the south of the entrance of the farmhouse, where it had been incorporated as a bench across an outside shelter or working place. The floor of this shelter was paved over a thin scatter of cairn material at a level 6 inches above undisturbed soil and the base of the peristalith wall. To the west of the shelter the peristalith wall had been robbed down to its footing, and its stones used to build the back wall of the shelter.

The peristalith here consisted of a battered revetting wall 1 foot 9 inches high, well built of small and uniform slabs, and supported externally by a ramp of similar slabs set at an angle of 45° to the horizontal. It thus



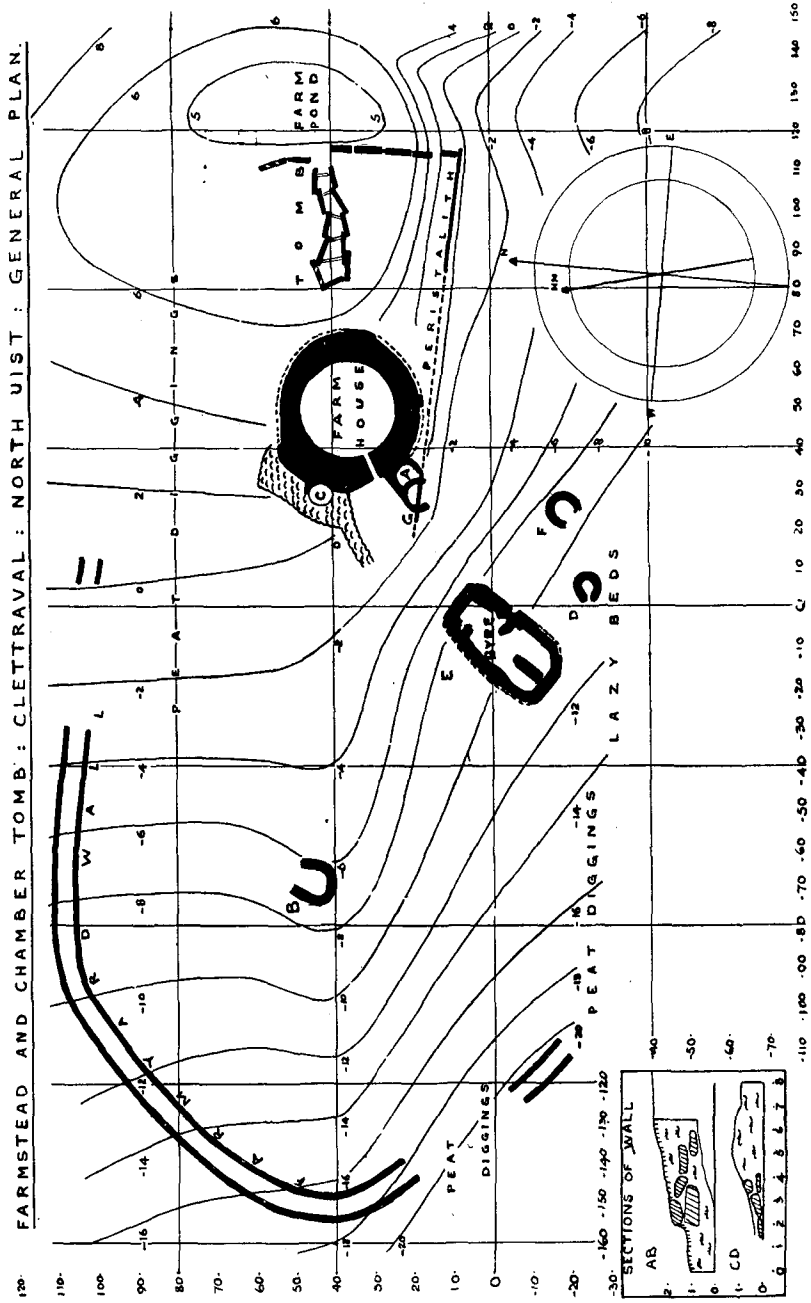

[From *Proc. Prehistoric Society*, 1948.

Fig. 8.

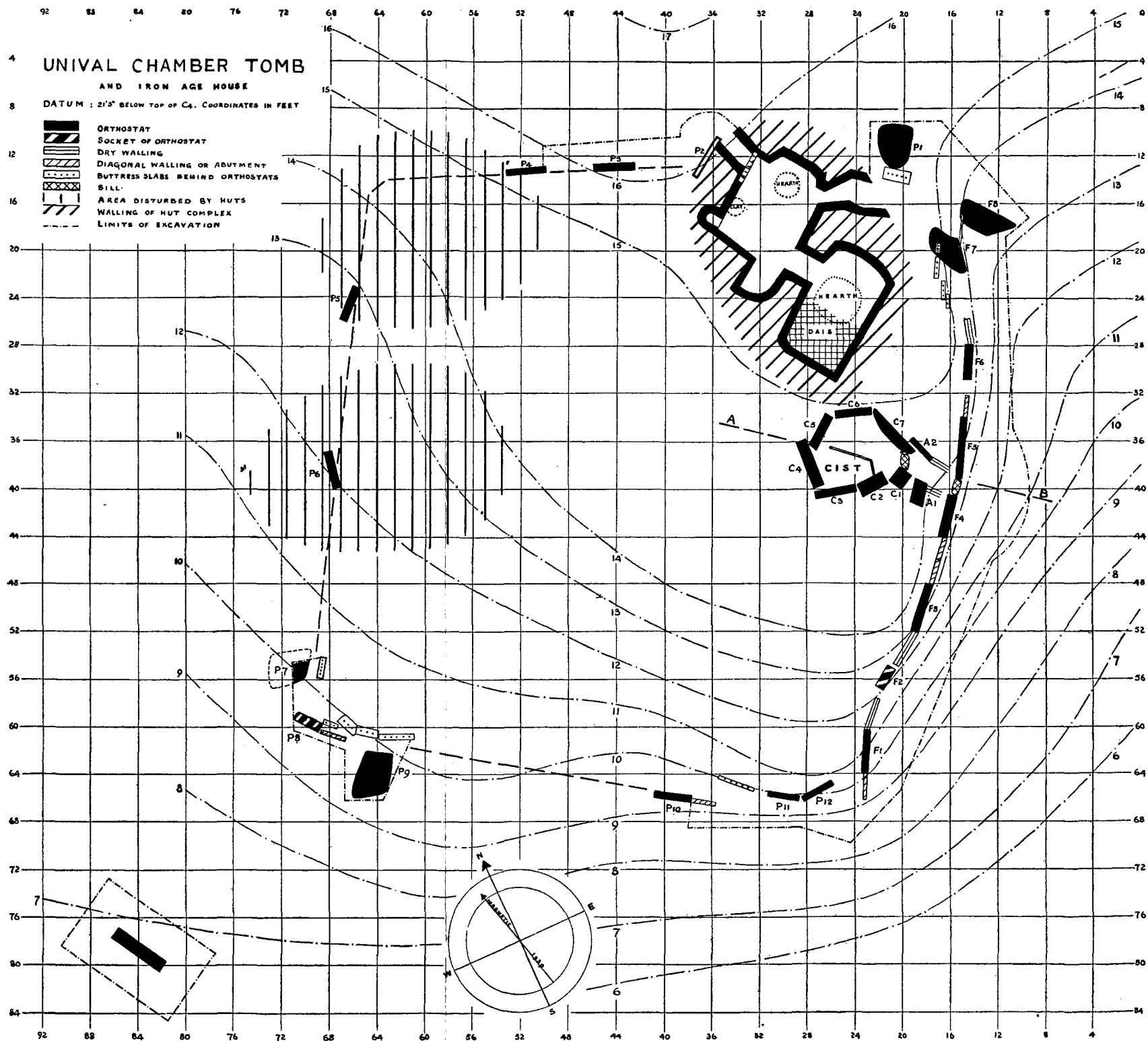

Fig. 1. General Plan.

corresponded with the middle and outer elements of the stretch of the peristalith described in the previous paper and illustrated there by fig. 11. The inner element there mentioned of large irregular boulders was missing, and it is possible that this should not be interpreted as an element of the peristalith, but as a structural revetment designed to hold up the cairn on the slope of the hill, and thus give a level cairn surface to the south of the tomb chamber.

The builders of the farmhouse took their material from the tail of the cairn, and also from the northern, and uphill, side of the cairn; this side, with the northern peristalith wall, had been so completely removed as to allow of peat diggings in recent times. The southern peristalith wall was evidently exposed to view when the shelter was built, and, from the total quantity of stone used by the farm builders, it can be calculated that the cairn had originally stood at most two feet higher than it now stands. (No cairn material had at any time been removed from the site, since there are no other stone structures in the vicinity.) Thus, while the peat diggings make it impossible to recover the line of the northern peristalith wall or the northern end of the façade, it may now be concluded: that the tomb enclosure was long and wedge-shaped; that the cairn did not cover the tomb chamber or the tomb façade; and that if, as is unlikely, the cairn extended outside the peristalith at all, it did not rise to a height to conceal more than its footing. (See also p. 31, note 1 *supra*.)