

## IV.

SOME NOTABLE PREHISTORIC AND MEDIÆVAL MONUMENTS  
RECENTLY EXAMINED BY THE ROYAL COMMISSION ON  
ANCIENT AND HISTORICAL MONUMENTS OF SCOTLAND.  
BY PROFESSOR V. GORDON CHILDE, D.LITT., D.SC., F.B.A.,  
F.S.A.SCOT., F.S.A., AND ANGUS GRAHAM, M.A., F.S.A.SCOT.,  
F.S.A.

*Read February 27, 1943.*

As part of its war-time programme, the Royal Commission on the Ancient and Historical Monuments of Scotland had occasion, during the past summer and autumn, to survey a certain number of ancient monuments of which no adequate description—and in some cases no description or notice of any kind—had previously been put on record. As most of these monuments happened to be situated in counties which are unlikely to be covered by the Commission's ordinary Inventories for many years to come, and as the Commissioners felt that the points of interest arising out of these surveys ought to be made generally available without such long delay, they have given us permission to communicate some notes on this work to the Society for publication in its *Proceedings*.

## CHAMBERED CAIRNS.

Three unpublished examples (two of which are, however, recorded in Sir George Macdonald's unfinished memoir<sup>1</sup>) lie within the areas visited in 1942. Opportunity is also taken to describe accurately for the first time the fine megalithic cist at Hailie, Largs, exposed in 1772 but known only from *The Statistical Account of Scotland* and a bad drawing in Smith's *Prehistoric Man in Ayrshire*, and also a pair of standing stones at Kames, Cowal, that look like remnants of a ruined chamber.

1. *Rottenreoch*, Muthill parish, Perthshire (6-inch O.S. map, xcv. S.W.), was first recognised by O. G. S. Crawford (Macdonald, *op. cit.*, p. 99). It is a stony mound running roughly S.W. to N.E., about 190 feet long and 43 feet wide at its N.E. end, contracting to 37 feet at the S.W., situated on gently sloping arable land on the S. side of the Earn valley nearly opposite Crieff and about 350 feet above sea-level or 200 feet above the present river channel. Some 14 feet from the N.E. end, slabs protruding through the turf suggest a cist lying somewhat skew to the axis

<sup>1</sup> Typescript in the Society's library.

of the cairn and possibly 12 feet long by 2 feet 3 inches wide. Near the centre and near the S.W. end other earth-fast slabs are visible that may also be remains of cists.

2. *Ardmarnock*, Kilfinan parish, Argyll (6-inch O.S. map, excii. N.E.). Just S.E. of Ardmarnock House, right on the W. edge, and at the N. end, of a rock ridge that runs from N.N.E. to S.S.W. with higher ridges immediately above it, stand the ruins of a fine megalithic cist at the N. end of an even more ruined long cairn. The cist has been opened and the whole site planted with trees which have displaced the stones with their roots and still more when they have been blown over (Pl. VIII, 1). The

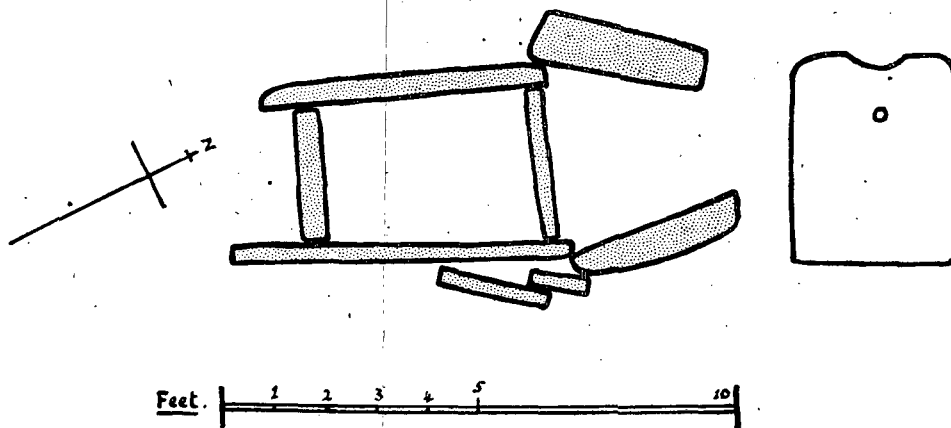

Fig. 1. Megalithic cist (plan) and septal slab (elevation), Ardmarnock.

(Crown copyright reserved.)

single chamber (fig. 1), internally 4 feet 9 inches long by 2 feet 8 inches to 3 feet 3 inches wide by 5 feet 6 inches deep, is formed by two enormous side slabs (5 feet 7 inches by 5 feet 5 inches on W. and 6 feet 4 inches by 4 feet 11 inches on E.), a headstone (2 feet 8 inches by 5 feet 6 inches by 7½ inches) fitting tightly between them, and a similarly situated septal stone 3 feet 3 inches wide by only 4 feet 3 inches high. It is preceded by a portal composed of two tall uprights now displaced by tree roots but measuring probably 7 feet 6 inches by 2 feet 11 inches wide by 10 inches thick on W. and 7 feet 6 inches by 3 feet 6 inches by 9 inches on E., both set outside and overlapping the side slabs of the cist but so that the minimum interval between their outer edges is only 2 feet to-day. Large slabs that once doubtless constituted lintels or corbels are lying to the west of the chamber on or against the uprights and portal stones. On the floor of the cist some traces of a slab paving, apparently running under the septal stone, are exposed. The "septal stone" exhibits features of special interest and seemingly unique in Scottish monuments of this group (Pl. VIII, 2). On its upper edge 1 foot from each end has been

hammered out a hollow in the form of an arc of a circle on a chord of 1 foot 3 inches and of a height (really depth) of 3 inches. A foot below the edge of this carving but not directly below its centre a cup-mark has been pecked out on either face of the stone. That on the inner face is only  $1\frac{1}{2}$  inches in diameter, but here the surface of the stone has peeled off. That on the outer face is surrounded by a well-defined ring, the overall diameter of cup and ring being  $3\frac{1}{2}$  inches, of the cup alone  $1\frac{1}{4}$  inches. The cups on both sides seem to correspond in position with remarkable precision.

To the N.W. of the portal rather uncertain traces of a horned façade may be discerned; the corresponding area on the N.E. has been completely disturbed by the uprooting of a large tree. Bushes and trees have left no superficial trace of the margins of the cairn, but on the axis of the cist cairn material extends for at least 70 feet. The Rev. Alexander McFarlane in *The Statistical Account of Scotland*, xiv. pp. 258–259, states that from what remains of this cairn or *borradh* it seems to have been only 20 yards long. He adds that “there is a tradition . . . that the cell” (*i.e.* the cist) “was the place where St. Marnock used to retire for purposes of devotion, fasting, and penance.” He himself thinks it more likely to have been a place contrived by plunderers for concealing their booty.

3. *Balmalloch*, Barr parish, Ayrshire (6-inch O.S. map, lxvii. N.E.). This is a large round cairn situated on the swampy moors above and east of Barrhill. It occupies a small grassy islet rising out of low-lying marshy ground between Half Mark Burn and Black Loch but hidden from Balmalloch farmhouse by rather higher and drier ground. Two chambers have been exposed at right angles to one another. The larger, with axis running N. and S. and probably opening to the S., consists of a cist 6 feet 6 inches long and 2 feet 6 inches wide at the inner end. The floor is littered with a bed of stones to an uncertain depth; the walls are formed of slabs on edge combined with drystone building, and the roof is corbelled, one lintel being still in position 4 feet above the bed of stones that hides the chamber floor. The S. end of this chamber is filled with debris that obscures any entrance passage there may have been. Nine feet N. of the headstone of the first cist is exposed the cracked capstone of another that may have opened to the E. The capstone is 6 feet long, 6 feet 6 inches wide, and 1 foot 3 inches thick. Below it at least three uprights forming the N. side of an irregular chamber can just be discerned.

4. *Hailie*, Largs parish, Ayrshire (6-inch O.S. map, iii. S.E.). This long cist was exposed in 1772 when a huge cairn, known as Margaret's Law and said to have contained fifteen thousand cartloads of stones (*The Statistical Account of Scotland*, ii. p. 363; xvii. p. 516), was removed. Nothing is left of the cairn, but the cist is still standing in an annex of Douglas Park on a narrow terrace some 50 feet above sea-level

immediately at the foot of Hailie Brae (Pl. IX). The complete inner compartment, orientated E. and W., measures internally 6 feet 6 inches by 3 feet 2 inches, and is roofed by a capstone 8 feet 2 inches long by 6 feet 6 inches wide by 1 foot 2 inches thick. It is supported by two side slabs 7 feet 2 inches long by 1 foot 10 inches thick on the S. and 6 feet 10 inches long by 1 foot 2 inches on the N., and a headstone fitting closely between the side stones. The capstone is now about 3 feet 8 inches above the stones which cover the floor of the chamber. The E. end of the chamber is partly closed by a septal stone 10 inches thick. Its upper edge is 1 foot 8 inches below the capstone, the edge of which projects 1 foot 6 inches E. of it. It is set so that its N. end is 1 foot W. of the end of the N. upright stone, but the corresponding end of the S. slab has been trimmed to accommodate the septal stone. East of the chamber the upper edge of a second slab, 4 feet 10 inches long, in line with, but not quite touching, the N. upright, projects above grass-grown debris and suggests a second compartment or a passage. This, however, does not seem to have been cleared below the edge of the septal stone and no corresponding slab is exposed on the S. In volume xvii. of *The Statistical Account of Scotland*, however, it is stated that the cairn covered five stone coffins, two of them containing five skulls each with other human bones and several earthen urns. As Macdonald remarks (p. 88), two at least of these "coffins" must have been "compartments of chambers or chambers."

5. At *Kames*, Kilfinan parish, Argyll (6-inch O.S. map, exciii. N.W.), overlooking the Kyles of Bute, is a pair of standing stones that look rather like the portal stones of a chamber. They stand close to the E., seaward, edge of the 100-foot raised beach platform immediately E. of a road opposite the post office, and are hidden in a thick hedge and partly buried in a turf dyke. The southern stone, the major axis of which runs E. and W., has an exposed height of 9 feet 10 inches along its W. edge, a width of 5 feet and a thickness of 1 foot 3 inches, its upper edge being sloped off on the E. Its counterpart, 3 feet 4 inches to the N. of it, is a tapering pillar 5 feet high as exposed, 2 feet 4 inches wide, and 1 foot 8 inches thick. The shape and position of the stones is compatible with the hypothesis that they formed the portal of a cist which with its covering cairn would naturally have been destroyed by the road. But there is no evidence to confirm such a hypothesis. About 20 yards away across the road is another standing stone, a flat slab 4 feet 8 inches by 3 feet 6 inches by 1 foot 10 inches facing W.

Of the foregoing monuments, that at Rottenreoch would seem to fit morphologically as well as geographically into the Earn valley group as represented by the well-known long cairn at Kindrochat, some 6 miles

to the W., and Clach na Tiompan near Auchnafree in Wester Glenalmond that was described by Coles,<sup>1</sup> but only recognised as a long cairn from his description by Macdonald (*op. cit.*, p. 100), and from examination by Mrs Stewart and Childe in 1938. The round cairn at Balmalloch no less clearly belongs to the Solway group, two other outliers of which are known in the S.W. corner of Ayrshire: the Commission's reports on Galloway have already drawn attention to round chambered cairns just across the county border.<sup>2</sup> Morphologically the cist at Hailie might belong equally to the Solway or Clyde types. At Ardmarnock on the other hand the portal stones and general plan are most appropriate to the Clyde group. The cup-and-ring marks and the incipient porthole of the "septal stone" are indeed unique in Scotland, but porthole stones are known in cairns of the same family on Man and in Northern Ireland,<sup>3</sup> and a near relative on a grander scale was reported at Auchnaha near Kilfinan 5 miles farther north ten years ago.<sup>4</sup> It is worth insisting that none of these chambered cairns are situated on hill-tops but all characteristically located on relatively low-lying ground.

#### ROUND CAIRNS.

Of the very numerous monuments of this class visited only a few deserve special mention.

On *Blackside*, Sorn parish, Ayrshire (6-inch O.S. map, xxix. N.E.), the flat-topped ridge forming the watershed between the Irvine and the Ayr, are two cairns. That at the S.W. end, Blackside End, has been despoiled for the building of a trigonometrical station and four small shelters like shooting butts. Several massive blocks protruding from smaller stones may mark the sites of short cists, but nothing visible suggests a megalithic chamber such as Macdonald (*op. cit.*, p. 90) was tempted to infer from the description given by Smith (*op. cit.*, p. 131). That on the N.E. end, Glen Garr Hill (6-inch O.S. map, xxiv. S.E.), is better preserved and seems to be 80 feet in diameter. A trigonometrical station shaped like a tower has been built on the centre of the cairn with stones robbed from the surface, but the core is probably intact.

On the summit of *Dungavel Hill*, Avondale parish, Lanarkshire (6-inch O.S. map, xxxvi. N.W.), at an elevation of 1502 feet above sea-level, there stands a large cairn of striking appearance (Pl. X, 1). The base of the cairn consists of an oval stony platform measuring 72 feet by 65 feet; on this stands, not quite centrally, a more or less circular super-

<sup>1</sup> *Proc. Soc. Ant. Scot.*, vol. xlv. pp. 98 ff.

<sup>2</sup> *Kirkcudbright*, p. xxviii; *Wigtown*, p. xxxviii; *Proc. Soc. Ant. Scot.*, vol. lxiv. p. 273, with two chambers.

<sup>3</sup> Childe, *Prehistoric Communities of the British Isles*, p. 51.

<sup>4</sup> *Proc. Soc. Ant. Scot.*, vol. lxvi. p. 416; *Trans. Glasgow Arch. Soc.*, vol. ix. (1937), pp. 6-12.

structure about 45 feet in diameter. The lower part of this, up to a height of about 4 feet, appears to be original, but on top of it there has been raised a pyramid of loose stones about 6 feet high, probably to serve as a trigonometrical station.

A very large grass-covered cairn stands in a conspicuous position some 600 yards N.E. of the farm of *Strathgroy*, Blair Atholl parish, Perthshire, about 1000 feet above sea-level. It is marked "Sithean," or Fairy Mound, on the 6-inch O.S. map (xxx. N.E.), but not in the Gothic type used for ancient monuments. In plan it is approximately circular, with a diameter of about 125 feet; and its height varies, in different parts of the circumference, from 14 feet to 18 feet above a zone in which a number of large blocks, somewhat suggestive of a peristalith, appear through the turf in addition to exposures of natural rock. Apart from these blocks it appears to be constructed of smallish rounded stones, though the whole surface is thickly grassed over. The summit is flattish, and here, almost at the centre of the cairn as seen on plan, two side-slabs of a ruined cist project above the turf. The axis of the cist was approximately E. and W.

Another cairn, somewhat resembling the Strathgroy "Sithean" but smaller, stands close to the left bank of the Fender Burn some 350 yards W.N.W. of *Monzie Farm*, Blair Atholl parish, Perthshire, at an elevation of about 1050 feet above sea-level. It is not marked on the 6-inch O.S. map (xxi. S.E.). The cairn, which is built on one end of a glacial hummock, is approximately circular on plan, measuring 84 feet by 78 feet, and its height varies from 8 feet to 15 feet at different parts of the circumference; all these measurements, however, are given with reserve because the cairn itself is covered with grass and it is consequently difficult to determine exactly where its slope passes into that of the underlying natural mound. The summit is somewhat flattened, and disturbance shows that the cairn is constructed of large quarry-stones such as might have been obtained from the rocky sides of the Fender Burn nearby.

On the W. side of Glen Clune below *Loch Moraig*, Blair Atholl parish, Perthshire, lies an area of moorland which contains many remains of hut-circles as well as of abandoned post-mediaeval farms. A cairn, which is not marked on the 6-inch O.S. map (xxi. S.E.), stands on a low natural hillock about 600 yards S.S.W. of the S. end of Loch Moraig. It is covered with grass and heather, measures 36 feet by 32 feet, and is reduced to a height of about 1 foot. The interior has been dug out, and in the hollow appear two erect slabs, evidently side-slabs of a cist.

In the cultivated haugh immediately below *Dunfallandy House*, Logierait parish, Perthshire, there stands a large cairn, which is now turfed over and planted with trees. It is not noted on the 6-inch O.S. map (xl. N.W.). It is constructed of large rounded stones and earth and measures 60 feet by 48 feet on plan; its sides rise steeply to a flattened

top the surface of which, though disturbed, shows no trace of any cist. An interesting feature of this monument is that it appears to be partially enclosed by a very shallow ditch with a low mound outside it; but on the strength of superficial observation alone it is impossible to be certain whether this is actually the case or whether the mound simply represents the remains of a ruined stone dyke—to which may perhaps have been added stones cleared from off the adjoining arable ground.

#### DOMESTIC STRUCTURES OF UNCERTAIN AGE.

Our season's work included some observations on hut-circles and early homestead-settlements in Perthshire. Very large numbers of huts and enclosures were observed in an area lying, at elevations of 900 feet and more above sea-level, on and near the upper waters of the *Kinnaird Burn* and its tributaries, in Moulin parish, and along the old road, attributed to General Wade, that runs over from Moulin to Strathardle (6-inch O.S. map, xxxi. S.W.). The remains included round huts, groups of huts combined with field-enclosures, small oblong huts, and "long-houses" of larger dimensions, as well as great numbers of piles of stones apparently gathered from off the cultivated plots. The large round huts seemed to resemble some of the types examined by Thorneycroft at Dalrulzion;<sup>1</sup> the widely splayed entrance and the low semicircular platform outside the entrance, which he recorded, were both observed, although double circles, whether concentric or tangential, were not. However, our examination of this very large area was necessarily too superficial for such negative evidence to be valid. Round huts built on sloping ground were often partly dug out to bring their floors to a level, and two, at least, of these contained an unexcavated step or platform on the upper side of the interior. What may probably be regarded as an extension of this same area was noted as far to the E. as the Pitlochry-Blairgowrie road, at a point about half a mile above Gatehouse.

Similar remains were also observed on the W. side of *Glen Clune*, Blair Atholl parish (6-inch O.S. map, xxi. S.E.), on the moorland lying between the cultivable lands respectively above Strathgroy and below Loch Moraig. Some notes on the huts observed on the *Muir of Gormack*, Kinloch parish (6-inch O.S. map, lii. N.E.), will be found on p. 48.

*Earth-house, Barns of Airlie*, Airlie parish, Angus (6-inch O.S. map, xxxvii. N.W.), is the survivor of a group of five and has been adequately described by A. Jervise.<sup>2</sup> To his description it is necessary to add only a mention of lintelled openings on both sides of the present entrance—a gap in the roof probably secondary. The point of the present note is to draw

<sup>1</sup> *Proc. Soc. Ant. Scot.*, vol. lxvii. pp. 193 ff.

<sup>2</sup> *Ibid.*, vol. v. (1864), pp. 352-3.

attention to some remarkable carvings on the earth-house roof, which have been known locally for several years but were dismissed by Jervise as natural. The curved gallery, the width of which at the wall heads has been reduced by corbelling to 3 feet 3 inches or 4 feet, is spanned by fifteen large lintels, 3 feet to 4 feet wide. On the eighth lintel<sup>1</sup> six or more serpent-like figures have been pecked out (Pl. X, 2). The "heads" of all the figures are represented by large round cup-marks, the serpents' bodies by gutters, shallow and narrower but still executed in the "Bronze Age" pecking technique as the photograph shows. The last serpent visible on Plate X (*i.e.* the one on the left as one enters the gallery) may curve round to the left so as to frame the whole group; the second is beautifully sinuous. The carvings have evidently been executed before the lintel was placed in position, since some are partially obscured by the topmost oversailing courses of the gallery walls. Cup-and-ring-marked slabs in conspicuous positions in the Strathmore earth-houses have been often noted:<sup>2</sup> they have been interpreted as Bronze Age stones re-used. But neither in the Bronze nor Iron Age has such a group of conventionalised zoomorphic carvings been previously recognised in Scotland.

#### PREHISTORIC FORTS.

We are able to record two unnoted *vitrified forts*, to amplify significantly available accounts of two others, and to add to the list two certain *brochs*; we wish also to draw attention to certain other defensive constructions of exceptional character not previously described.

*Vitrified Fort, Machany*, Blackford parish, Perthshire (6-inch O.S. map, cvii. S.E.). Just E. of the road from Muthill station to Auchterarder the cultivated land that slopes gently N. to Machany Burn is interrupted by a very low ridge on which has been planted a small wood. Within the boundary of the wood the visitor can just discern the effaced and grass-grown remains of a stony rampart enclosing an oblong space some 180 feet E. and W. by 130 feet N. and S. The outer margin of the rampart on the S.E. is marked by a discontinuous row of slabs on edge some of which are tilted out of line. But in the core behind the line of slabs large lumps of vitrified stone are exposed, particularly at the S.E. and N.E. corners. The O.S. map marks a "chapel" here; nothing of this remains, but it presumably occupied part of the site of a much older vitrified fort. The existence of the latter is undoubted, and the plan seems characteristic although the location is most unusual.

The fort on *The Knock*, Largs, Ayrshire, is marked on the 6-inch O.S.

<sup>1</sup> The lintel is 3 feet 4 inches wide, 5 feet 7 inches above the floor where the passage is 6 feet 9 inches wide, and is certainly over 4 feet long, the least clear space between the corbel edges being 3 feet 5 inches.

<sup>2</sup> Childe, *Prehistory of Scotland*, p. 213.



map (iii. N.E.), and is mentioned cursorily by Christison,<sup>1</sup> who did not, however, note the presence of vitrification. The summit of the hill, which rises just over 600 feet above sea-level, is surrounded by a rampart enclosing a sub-oval area measuring about 165 feet from N. to S. by about 95 feet from E. to W. where broadest. The rampart is stony but turf-covered, and nowhere stands more than 3 feet above the adjoining part of the interior. Outside the rampart, and from 6 feet to 8 feet below its crest, a shallow rock-cut ditch appears at the S. end as well as on the N.W. and N. In this last sector the ditch is bordered by a low counterscarp-bank; but on the N.E. the outer defences have been destroyed by a modern access-road, while towards the W. the ditch fades out into a terrace. The original entrance may have been on the S.E.

A recent disturbance of the surface at the S. end of the fort has resulted in the formation of a small scree of angular broken stones descending from the top of the rampart into the ditch, and it was here that several pieces of vitrified stone were picked up in the loose material of the scree. As might have been expected, the larger lumps occurred at the bottom of the scree, but enough smaller fragments were observed at higher levels to make it certain that the others had fallen from the rampart itself.

At *Portnacross*, West Kilbride parish, Ayrshire (6-inch O.S. map, x. N.E.), the ridge Auldhill, immediately behind the port and castle, ends in a peak, precipitous on W., N., and E. The W. and E. edges of the extremity are defended by vitrified ramparts enclosing a level grassy subrectangular space, over 100 feet N. and S. by 50 feet wide, the grass-grown ramparts not rising appreciably above the level of the interior. S. of this space the ridge is crossed by two ditches with a low ridge, apparently of unquarried rock, between them. To the S. a higher ridge of rock forms the N. boundary of a subrectangular *dùn* 45 feet N. and S. by 27 feet wide, defended on the W., S., and S.E. by a wall of coursed rubble masonry. This seems to belong to a secondary structure, prehistoric or even mediæval, that may have truncated the earlier vitrified fort.

*Kildoon Hill*, Maybole parish, Ayrshire (6-inch O.S. map, xlv. S.E.). This well-known vitrified fort occupies the E. end of a basalt ridge over 600 feet high, the vitrified rampart enclosing an irregularly oval area of about 150 feet by 100 feet partly taken up by a monument to Sir C. Fergusson of Kilkerran, the construction of which has partly destroyed the defences. The neck to the W. is defended by two rock-cut ditches with ramparts of broken stone on the E. side of each. The vitrified rampart seems to lie inside and to the E. of the innermost of these banks, and is partially separated therefrom by a series of discontinuous hollows, though the space might also be described as a platform interrupted by hollows. The vitrified masses are almost entirely hidden by turf. Here

<sup>1</sup> *Proc. Soc. Ant. Scot.*, vol. xxvii. p. 398.

again it looks as if the high banks and ditches defending the neck belong to a later work than the vitrified rampart.

*Brochs.* on Mull are shown in the distribution map given in Childe's *Prehistory of Scotland*, but none have been described. Last year's examination disclosed the following certain examples.

*Dùn nan Gall*, Ballygowan, L. Tuath (6-inch O.S. map, Argyll, lxviii.), stands on the north shore of the loch on a low rocky promontory that forms the S.E. side of Ballygowan Bay into which a stream flows. It was partially excavated by the late J. H. Craw just before his death. It now appears as a conspicuous pile of naked stones in which the following features are partially exposed. An entrance on the E., 4 feet wide at the mouth expanding after 3 feet 8 inches, where there is a door check 7 inches deep and a bar-hole; an internal doorway 3 feet 6 inches wide on the S. giving access to a stairway 3 feet wide of which three treads survive; a slightly doubtful internal door on the N.E. probably 2 feet 6 inches wide and leading to a guard chamber; a scarcement 7 inches wide visible nearly all round, above which the inner wall still rises in places a couple of feet; it is 2 feet 8 inches thick, and outside it at scarcement level runs a well-floored mural gallery of uncertain width; at the same level is a gap 2 feet 4 inches wide in the inner wall on the west but not quite symmetrically opposite the door. Above scarcement level nothing remains of the outer wall of the gallery. The wall at scarcement level has a total thickness of 10 feet 6 inches on E. to 11 feet 6 inches on W. The internal diameter is 35 feet. There can be no possible doubt that this is a broch.

*An Sean Dùn* occupies the high N.W. end of a ridge that slopes up from the moors between Mingary and Glengorm (6-inch O.S. map, Argyll, xxxviii.). A wall about 10 feet 6 inches thick about scarcement level encloses a space 32 feet in diameter filled with debris and scrub. The following features are exposed: an entrance on the S.E. 3 feet 6 inches wide at the mouth with a door check 3 feet 6 inches in; just within the check a gap in the much-dilapidated western wall of the entrance passage that may have given access to a guard cell; a gap or door in the inner wall on the W.S.W. 3 feet 6 inches wide that must have given access to a stair room; no stair is preserved, but the inner face of the stairway separated from the inner face of the court by 2 feet 8 inches of masonry is visible; a scarcement 12 inches to 15 inches wide. To the S.W. of the entrance a dilapidated structure of inferior masonry has been built on to the broch wall. There can scarcely be any doubt that this is a broch.

Of numerous other undescribed "forts" visited last year, only three sites are of such exceptional interest as to deserve description here.





1. Megalithic cist, Hailie.



2. Megalithic cist, Hailie, from south-west.

CHILDE AND GRAHAM.

NOTABLE PREHISTORIC MONUMENTS.

*(Crown copyright.)*

[Facing p. 40.]



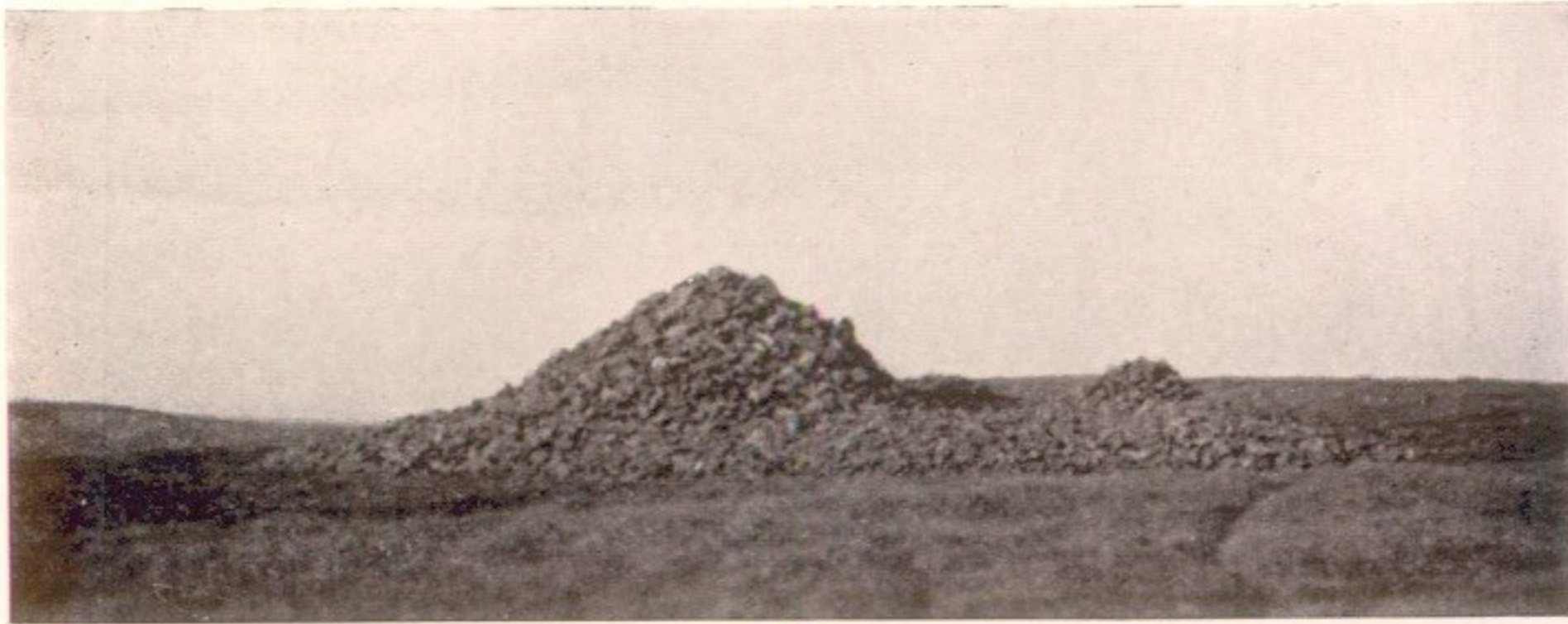

1. Round cairn, Dungavel Hill.



2. Carved lintel, Barns of Airlie.





1. Dùn a' Choin Dhuibh: postern door to tower.



2. Dùn a' Choin Dhuibh: outer rampart.





1. Dùnan na Cleithe: standing stones with inner rampart behind.



2. Buzzart Dykes, north-west corner.



*Dùn a' Choin Dhuibh*, S. Knapdale parish, Argyll (6-inch O.S. map, cii. N.E.), stands on an isolated crag overlooking West Loch Tarbert from the N. The S.E. corner of the extreme summit is occupied by a tower-like *dùn*, while the rest of the summit and a shoulder some 10 feet below it on the N. is protected by a built rampart (fig. 2). The tower walls still rise on the W. 6 feet to 8 feet above the skirt of fallen stones and, being built

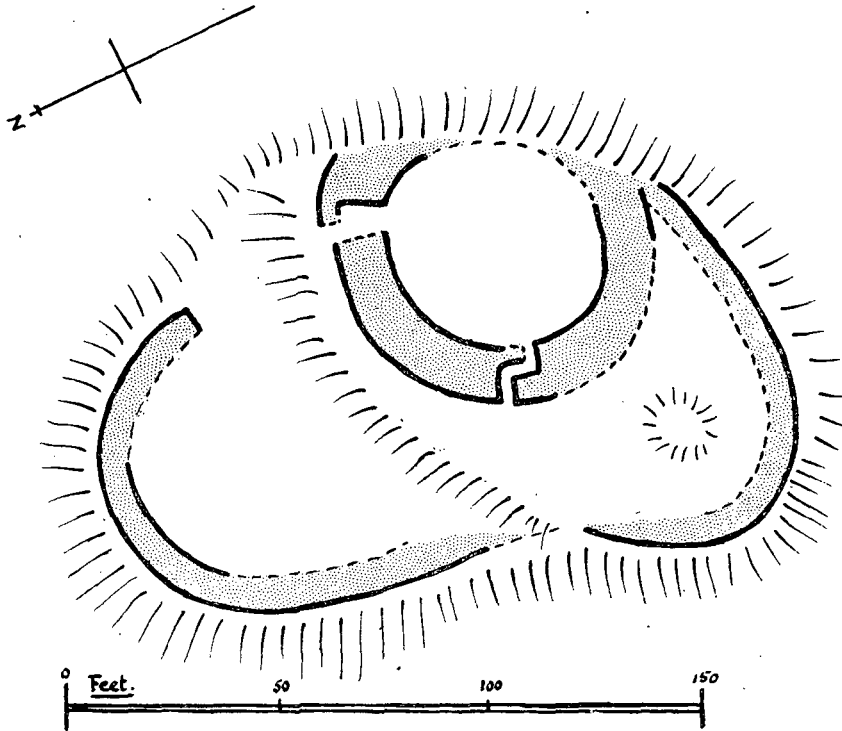

Fig. 2. Dùn a' Choin Dhuibh.

(Crown copyright reserved.)

with heavy batter, measure from 9 feet 6 inches to 10 feet 3 inches in thickness. But the whole S.E. quadrant of walling, that may have been 11 feet thick, appears to have toppled down the precipitous slope. Still the internal diameter of the tower can be estimated as 45 feet E. and W. by 40 feet N. and S. On the N.E. there is an entrance passage 4 feet 3 inches wide at its inner end. In the W. wall an external opening 2 feet 4 inches wide spanned by a humpbacked lintel (Pl. XI, 1) gives access to a passage that runs straight, though apparently descending, for 5 feet 6 inches and then turns sharply to S. It can be followed for a further 5 feet 3 inches in the new direction but still descending (the roof at least is at this point 1 foot lower than at the first turn), and then turns E. again.

so that it should debouch on to the interior after 4 or 5 feet. For the first 5 feet the passage is simply lintelled over but thereafter is roofed by corbelling as far as it is preserved.

In the N.W. corner of the summit between the tower and the outer rampart is a jagged outcrop the W. side of which appears to have been quarried so as to form a rough seat.

The outer rampart which follows closely the edges of the crag is more roughly built than the tower wall and comprises a larger proportion of thin flat slabs split off the rock. Still in places its outer face is preserved to a height of 4 feet to 6 feet. On the E. a gateway, of which the N. jamb is a large slab on edge, gives access to the shoulder below, and some 30 feet in horizontal distance from the N.E. entrance to the tower. South of the gate, if the line of the outer rampart were continued, it would have abutted upon or run under the tower wall. On the summit too the outer rampart face at present terminates on the S. on the brink of a cliff below but only 4 feet from the foundation of the tower wall face. But at least one stone of the latter rests on stones apparently belonging to the core of the outer rampart. It is therefore possible that the tower was built later than the outer rampart.

On the shoulder three small rings of boulders were observed thirty years ago abutting against the outer rampart. One was dug into and much iron slag recovered. If the outer wall then exposed be really the inner face of the rampart, the latter will have been 7 feet 6 inches thick, but this is not quite certain.

*Dunan na Cleithe*, S. Knapdale parish, Argyll (6-inch O.S. map, exc. N.E.), occupies a wooded ridge of rock about 35 feet high between Loch Caolisport and the drive to Ormsary House. The N.W. end of this ridge is cut off by a distinct rampart faced externally with large blocks and running almost straight N.E. to S.W. for some 60 feet. About 40 feet outside it there seems to be a curving outer rampart. From it protrude two standing stones some 2 feet apart, but not in line, each about 2 feet wide and respectively 3 feet and 3 feet 3 inches high (Pl. XII, 1). Some 18 feet 6 inches N. of this pair is a large recumbent block now measuring 2 feet by 1 foot 4 inches by 1 foot 3 inches. The two uprights produce the same impression as the standing stones usually assigned to the Bronze Age. Yet they appear integrally connected with an Iron Age fort.

Finally five other forts, not marked on the O.S. maps, may be mentioned shortly: (1) On *Aird Kilfinichen*, a promontory on the N. side of L. Scridain, Mull (6-inch O.S. map, Argyll, xciv.), an oval *dùn* measuring internally 50 feet by 57 feet on the tidal Eilean na h'Ordaig with an outwork on one side. (2) *Caisteal na Site*, Kilfinan parish, Argyll (6-inch O.S. map, exciii. S.W.,  $55^{\circ} 52' 19''$  N.,  $5^{\circ} 15' 23''$  W.), a D-shaped enclosure 260 feet long on the summit of a rocky ridge over-



hanging the tiny burn that flows into Allt Osda below the old Chapel of Kilbride, defended by a stone rampart faced externally with flat slabs so loosely coursed as to suggest a combination of stone and timber work. (3) *Kilbride*, Kilfinan parish, Argyll (6-inch O.S. map, exciii. S.W.), on a small rocky whale-back west of Allt Osda valley, a *din* with an internal diameter of perhaps 58 feet by 51 feet defended by a dilapidated stone rampart and natural outcrops. Both (2) and (3) have been discovered by Mr J. W. Turnbull, F.S.A.Scot. (4) and (5) near *Aldclune*, Blair Atholl parish, Perthshire (6-inch O.S. map, xxx. N.E.). These two forts are

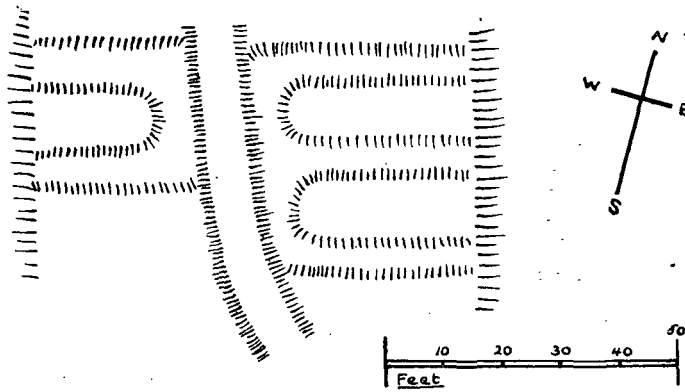

Fig. 3. Causeway and its defences, N.W. fort, Aldclune.

(Crown copyright reserved.)

situated about 200 feet apart on a wooded ridge lying on the N.E. side of the highway about half a mile N.W. of Aldclune village, and the difference in their state of preservation is so marked as to suggest a considerable difference in their ages, if not indeed a deliberate demolition of the N.W. member of the pair.

The approach to this latter fort has been by a narrow cambered causeway following the crest of the ridge. On either side of a section of this causeway, 40 feet in length, extending between points distant respectively 58 feet and 18 feet from the edge of the flattened interior of the fort, there is a system of ditches and banks which might well be regarded as a road-block connected with the fort's defensive works. On its E. side the causeway is bordered by a ditch for nearly 40 feet, and from this ditch three other ditches, which enclose two banks between them, strike off at right angles and run out, as do the banks also, on the steep flank of the ridge. On the W. side of the causeway there is a corresponding arrangement, but it contains only two branch-ditches with a single bank between them. The ditches and mound on the W. are deeper and more clearly defined than those on the E. (fig. 3).

The attention of the Commission's officers was drawn a few years ago

to some remains of this kind on Dère Street, about a third of a mile S.E. of the fort on Woden Law, and the suggestion was made that these represented a road-block, possibly of Roman construction. Subsequently, however, they found that similar remains occurred fairly commonly on many of the old roads in the Cheviot district, so much so that their defensive character came to be questioned and they were tentatively classed as boundary marks.

#### MOTES.

Turning now to defensive structures belonging to a later period, we have been able to identify four motes with reasonable certainty.

The mote of *Struan*, Blair Atholl parish, Perthshire, was described in the *Proceedings* many years ago,<sup>1</sup> but the author failed to recognise the nature of the monument and his account of it is worth very little. The 6-inch O.S. map (xx. S.E.) notes it merely as "Tom an Tigh Mhoir." That it is actually a mote, however, cannot be doubted. The monument, which is situated about 150 yards W. of Struan Church, consists of a large grass-covered mound, with a flat top of irregular quadrilateral shape measuring about 62 feet each way. It rises from the lip of an almost precipitous slope which falls from the level of the cultivated fields to the right bank of the River Garry, the N. side of the mound forming one profile with this slope. The E. and S. sides fall steeply down to the field, the maximum height being 17 feet measured near the N.E. corner. The W. side falls 15 feet to the bottom of a ditch, which embraces the W. and S.W. sectors; this ditch finishes in a rounded end about the middle of the S. side, and on the N. widens out and debouches on the slope above the river-bank. There is nothing to show that a corresponding ditch was ever dug on the E. side of the mound. The foundations of a rectilinear enclosure can be seen bounding the summit of the mound, on which also appear narrow cultivation-rigs. The foundations therefore may well be relatively modern, as may also the foundations of a wall which run down the S. slope; while the rather massive stone-work that appears in the uppermost part of the slope at the N.W. corner may likewise have been intended to level up the summit for agricultural purposes.

A second undoubted example of a mote is the *Castle Hill*, Alton, Loudun parish, Ayrshire (6-inch O.S. map, xviii. S.E.), although it is not recognised as such either by Christison<sup>2</sup> or by Smith.<sup>3</sup> It is a flat-topped, stony, grass-covered mound standing between a road and the precipitous bank of a burn about 300 yards N.E. of Alton. The summit is D-shaped, and measures 40 feet along its straight N. side by 25 feet transversely; except along its N. side, the edge of the summit bears some slight remains of a rampart. The N. side of the mound is continuous with the bank of

<sup>1</sup> Vol. vii. p. 442.

<sup>2</sup> *Proc. Soc. Ant. Scot.*, vol. xxvii. p. 402.

<sup>3</sup> *Op. cit.*, p. 98.

the burn, and the other sides slope down fairly steeply to the field lying about 12 feet below. At the foot of the mound on the E. there is part of an enclosure bounded by another much-wasted rampart; this is cut off by the road, but a slight elevation which may mark its continuation can be traced on the S. of the road as far as the ruins of a cottage.

Another mound which may be confidently regarded as a mote is the so-called Green Hill which stands on a bluff just outside the entrance-gate of the *Halkshill* policies, Largs parish, Ayrshire (6-inch O.S. map, iii. S.E.). Smith mentions this mound,<sup>1</sup> but implies that it is sepulchral. The mound stands to a height of about 16 feet above the top of the bluff, its S. side being continuous with the clay cliff below. The summit has been much interfered with and bears three modern masonry columns, but it seems to have once been level and may have measured about 35 feet by 20 feet. Stone-work appearing through the turf on the summit suggests the foundations of a building about 15 feet square; and further traces of tumbled stone appear on the N.W. slope, where a path has broken the surface.

A fourth monument which we felt fully justified in identifying as a mote was *Cnoc Mhìc Eoghainn*, Kilfinan parish, Argyll (6-inch O.S. map, clxxi. S.E.). This is a mound, apparently composed of earth not at all free from rounded boulders, which stands about 110 yards W.S.W. of Ballimore House and about 100 yards from the shore. It has the form of a truncated cone 25 feet to 30 feet high, now planted with trees and shrubs, its flat top being oval in form and measuring 80 feet by 50 feet. On the summit there stands a masonry enclosure used as a family burying-place, and the construction of this must have resulted in the modification of the summit to an extent difficult to gauge—for example, an access-road which has been cut in the side of the mound may have reduced its major axis by as much as 10 feet. On the E., S., and W. the base of the mound is encircled by a marshy ditch. On the N.W. the O.S. map marks a small earthwork annex which was not observed at the time of visit owing to the dense growth of shrubs.

#### MISCELLANEOUS.

*Buzzart Dykes*, Kinloch parish, Perthshire. The area enclosed by this earthwork is labelled "Caledonian Camp" on the 6-inch O.S. map, lii. N.E., apparently on the authority of James Playfair, minister of Bendothy from 1784 to 1812.<sup>2</sup> His speculations having been thus

<sup>1</sup> *Op. cit.*, p. 7.

<sup>2</sup> *The Statistical Account of Scotland*, vol. xix. (1797), p. 368 f.n.; cf. McRitchie, *ibid.*, vol. ix. (1793), p. 262 f.n.; and Brodie, *ibid.*, vol. xvii. (1796), p. 479. The latter argues that the Dykes are the defences of Galgacus' encampment at the Battle of Mons Graupius, the actual battlefield being marked by Haer Cairns, equating *Haer* with German *Heer*!



interrupted by gaps about 13 feet wide from crest to crest which give access to narrow causeways across the ditch. At the middle of the N. and the S. ridges the gaps are double, the northernmost of the latter pair being used by a track marked on the 6-inch map. The work disappears for about 20 feet in the marshy bottom of the hollow dividing the northern from the middle ridge. On the S. the work breaks off abruptly on the steep edge of the wide ravine through which the Lornty Burn flows 15 feet below, giving the impression that its continuation has been eroded away. (While the slope immediately below is grass-grown, immediately to the E. the bank has been recently eroded and consists of loose clay.) The work cannot be seen on the low-lying marshy land immediately S. of the stream but can be picked up after it has turned E. on the S. bank of the ravine. It looks as if the corner had been eroded when the burn cut down its channel. From this point rampart and ditch run eastward for almost a mile on the plateau edge south of the ravine, but they are interrupted at several points by bends of the river and the accompanying terrace bank. On the edge of each of these sinuosities the rampart and ditch seem to be cut away abruptly by the scarp and can be picked up again on the same line E. of the bend. Though the burn flows now 20 feet to 25 feet below the terrace followed by the earthwork it seems clear that these sections have been destroyed by erosion. Near its S.E. corner, after emerging from one of these eroded bays the scarp of which is still bare, the work descends on to haugh land and then terminates a few feet west of the burn just opposite the point where a mill lade takes off. Owing perhaps to this recent disturbance the continuation on the opposite bank is not obvious, but about 10 feet above the burn a small fragment is preserved just below the road from Millhole. This fragment probably marks the S.E. corner and above it bank and ditch should be running N. They have, however, been quite ploughed out across the southern ridge, and can be first recovered on the northern slope of the middle ridge where only the colour of the grass marks the line. Hence it can be traced running not quite straight up the N. ridge. From the modern dyke on top of the latter to the northern boundary-stream, rampart and ditch are visible though much denuded and filled up. The N.E. corner is on marshy ground where the turn of the earthwork is not clearly defined. The line of the N. side is continued eastward by a broken-down stone dyke running on towards Middleton Farm. The N. bank follows the N. side of the stream in a marshy hollow westward, the stream at present in parts taking the place of the ditch on the inside of the rampart though at some points the earthwork ditch is distinct from and N. of the stream's channel. On marshy ground the rampart and ditch fade out completely for stretches, but sometimes discontinuous lumps of rampart can be recognised in the marsh. It is therefore possible that it has been submerged in places,

though, walking the line on the marshy ground, no rampart can be felt underfoot. The N.W. corner is thus obscured in a swampy patch.

On the crest of the southern ridge 800 feet above sea-level just 14 feet within the western ditch and close to the gap is a well-preserved hut-circle 41 feet in diameter from crest to crest. Further east are remains of irregular enclosures bounded by stone walls with rounded corners.

Outside the dyke to the S. on the Muir of Gormack are two groups of three and two hut-circles respectively, the best preserved circle measuring internally 31 feet in diameter. Rather farther W. and closer to the dyke on the valley edge are ruinous remains of a circle or enclosure or cairn. On the gently sloping ground S. and E. of the circles are distinct remains of irregular enclosures and extensive clusters of small cairns marked "Haer Cairn" and "Cairns, Site of" on O.S. map.

Similarly on the next ridge N. of the dyke on Cochrage Muir there are fields of small cairns on the level top of the ridge towards the E. and, slightly higher up to the W., the very ruinous remains of hut-circles with attached field plots among deep heather. There are other cairns W. of the dykes on the southernmost ridge. In no case can any determinate relation between the earthwork and the hut-circles and cairns be recognised.

#### HOMESTEAD SITE.

A few words must also be said about what may be called a "homestead," situated on the hillside above *Strathgarry Farm*, Blair Atholl parish, Perthshire, about 750 feet above sea-level and 350 feet above the valley-bottom (6-inch O.S. map, xxx. N.E.). This monument is of interest on account of the strong resemblance that it bears to a type of structure which, though extremely common in the Borders<sup>1</sup> and known as far N. as the immediate vicinity of Edinburgh, does not appear to have been reported previously from anywhere N. of the Forth. The remains consist of a large hut-circle, measuring 83 feet by 72 feet over a wall which is 9 feet 6 inches thick where measurable but which elsewhere spreads out to form a bank as much as 12 feet across. The back wall and the slope that results from the process of scooping jointly account for some 32 feet of the minor axis. The lowest course of the outer face of the wall exists in one sector for a length of 47 feet; the wall here has been built of large blocks on either face, with a core of smaller and generally rounded stones. A field-wall of stones and turf adjoins the side of the hut at the end of this sector; its facing-stones are similar to those of the hut-wall, and the two walls seem to be of continuous construction.

<sup>1</sup> For an account of the excavation of one of these sites, cf. *Proc. Soc. Ant. Scot.*, vol. lxxv. pp. 92 ff.

## "WALLACE'S STONE."

In view of the divergent opinions that have been held on the subject of the monument thus named,<sup>1</sup> it will be well to add, in conclusion, a factual description of it. The stone itself is a granite boulder, 6 feet in length, which now lies prostrate on the S. side of the drive leading to Blairston Mains, Maybole parish, Ayrshire (6-inch O.S. map, xxxix. N.W.). It bears on its upper surface the pecked-out figure of a cross, which was correctly identified as such by Smith although it has been mistaken for a sword—perhaps because it lacks its lower member. The cross, which is of the "Maltese" pattern, measures 3 feet 10½ inches in length by 1 foot 2 inches across the arms and is very rudely executed (fig. 5). The lower end of the shaft is pointed, which suggests that the artist's intention was to depict a wooden "stake-cross" or "stob-cross," such as are frequently mentioned in boundary descriptions in mediæval charters. Bede's record<sup>2</sup> of the wooden cross set up by King Oswald is well known.



Fig. 5. Cross on Wallace's Stone, Blairston Mains.  
(Crown copyright reserved.)