

THE CHAMBERED CAIRN OF CLETTRAVAL, NORTH  
UIST. BY W. LINDSAY SCOTT, F.S.A.Scot., F.S.A.

(Read 11th February 1935.)

LOCATION.

The chamber tomb, which is the subject of this paper, lies in lat.  $57^{\circ} 36' 51''$  N., long.  $7^{\circ} 26' 39''$  W., at a height of about 350 feet above the sea and some 80 feet below the southern summit of the ridge of Clettraval, from which I have proposed to name it.<sup>1</sup> Lower down the slope is a standing stone, and lower down still the chamber tomb known as Tigh Cloiche, both being marked upon the Ordnance Survey. There is no reason to associate the two tombs, which are of different types, or to associate either with the standing stone.

The southern slope on which the tomb stands is the termination of a low range of hills running parallel and near to the western coast of North Uist. This island of the Outer Hebrides tilts generally westward from its high eastern edge through a middle region of lochs and peat bogs to a level and sandy area facing the Atlantic, and the great bulk of the modern population is confined to the last area. Judging by the distribution of chamber tombs the neolithic population of the island extended in addition over the central area, which was then largely free of peat. Although the Clettraval tomb now stands in a peat bog no peat was found underneath it.<sup>2</sup> Birch charcoal was found in the chamber, whereas the island is now virtually treeless.

The tomb is set east and west on a narrow and gently shelving terrace on the southern slope of the hill; the site has not been levelled and the façade, running north and south, follows the natural slope. The terrace has operated to collect water, and a considerable growth of peat now overlies the original soil; modern peat cuttings immediately

<sup>1</sup> The tomb is not marked on the Ordnance Survey, and the position given above is calculated trigonometrically from the following data and must be taken to be approximate. A line joining Monach Lighthouse and North Uist Church cuts the Garry Tighary peat road, which here runs east and west, at a point from which the centre of the cairn bears  $115^{\circ}$ , distant approx. 200 yards. The latitude and longitude of the lighthouse are stated on Admiralty Chart No. 2805; the latitude and longitude of the church, and the latitude of the road, are measured from the 6-inch Ordnance Survey, Hebrides, North Uist, Inverness-shire, Sheets Nos. XXXIII. and XXXIV. respectively.

<sup>2</sup> A layer of peat 6 inches thick was found under the chamber tomb of Rudh' an Dunain, Skye (*Proc. Soc. Ant. Scot.*, vol. lxvi. pp. 183 ff.; and vol. lxxviii. pp. 194 ff.).

north of the tomb are filled with water even in dry seasons. The underlying rock is gneiss, which, on the steeper slopes, outcrops freely.

#### HISTORY OF THE SITE.

The history of the site subsequent to the period of use of the tomb has been unfortunate. At a period defined by an Iron Age A culture a circular stone fort some 26 feet in internal diameter, and with walls about 7 feet thick, was built over the western end of the cairn. A sketch plan of this fort is on Pl. I. The material of which it was built was obtained partly from cairn stones on its site, partly from stones from the eastern part of the cairn, and partly from slabs forming the actual structure of the tomb. By this means the cairn has been almost wholly removed; the degree of denudation can be seen from the sections in Pl. II. Two wall slabs and the northern half of the forecourt façade were taken away. The great slabs of the southern half of the façade appear to have proved not to be worth the effort of removing, for, while they had been dug out to their bases and thus allowed to collapse, they remain near their original positions. One had, however, been split laterally near its foot, and its upper part had been removed.

As a result of this activity the site was rendered a roughly level platform with a fairly steep scarp on its southern edge, created partly by the remains of the cairn and partly by the slope of the hillside. Across the south-eastern corner, overlying the southern part of the forecourt, a bank was built by occupants of the fort, and in the hollow thus formed peat had grown and stood to a depth of two feet over the centre of the forecourt (see Pl. II.).

When the fort in its turn had fallen into decay some secondary occupation of the broch period had taken place among its ruins. Two tangles of stones to the south of the fort represent use of its material to build huts or shelters, possibly in modern times, though it may be that excavation would show these to be hut circles of an earlier period. Finally, in modern times, peat digging had taken place up to the fallen wall of the fort and within what had once been the northern margin of the cairn.

With the consent of Mr Hector Mackenzie, a member of our Council, on behalf of the trustees of the late Sir Arthur Campbell Orde, Bart., the area indicated in Pl. I. has now been excavated. When the work began the site bore no more than the uninformative features shown in the excellent photograph published by the late Dr Erskine Beveridge in his valuable work on North Uist.<sup>1</sup> Considering the desperately

<sup>1</sup> Erskine Beveridge, *North Uist*, p. 254 (c).

wrecked and denuded appearance of the tomb the results have been in excess of all legitimate expectation.

#### THE FORT.

It will be convenient first to give the evidence obtained in the course of the excavation of the tomb regarding the Iron Age occupation of the site. Iron Age pottery was scattered thinly over the surface left when



Fig. 1. Entrance Passage of Fort looking inwards, showing slab-covering of the Drain which ran through it.

the cairn was denuded to build the fort, and in quantity in and under the bank which lay across the southern half of the forecourt. It was thought desirable to seek more precise evidence for the dating of the occupation of the fort by excavating a small area of it and, as shown in Pl. I., an area including the entrance was cleared.

The fort wall was found to be built upon an irregular foundation of boulders. The wall, to judge from its structure immediately to the west of the entrance, was composed of facings of stones, reasonably well chosen but not large, with a core of earth and rough blocks. Its thickness at the entrance was 7 feet. The fort, therefore, was of no great defensive strength, and differed wholly in its building from the massive and solid structure of the brochs.

Through the wall an entrance passage 2 feet 6 inches wide ran in an east-north-easterly direction (fig. 1). Its northern outer jamb was a small pillar, 2 feet 9 inches high, now fallen; its southern outer jamb was built of coursed masonry, now somewhat slipped. Through the entrance ran an unpaved drain formed of blocks laid on edge and covered with fairly large slabs. At the inner end of the passage was a threshold composed of two long blocks, raising the level 6 inches above the covering slabs of the drain, and rebates to hold a door. Within the fort, in the very small area examined, the floor rose 9 inches further to clear a boss

of solid rock, the natural level of the ground rising to the northward. The maximum height to which the wall of the passage now stands above the slab flooring of the drain is 3 feet; there are no remains of roofing. Inside the fort, and to the north of the entrance outside, the wall stands to 4 feet above its foundations.

Above the slab-covering of the drain was a second floor about one foot higher composed of slabs laid upon blocks set on edge on the lower floor. This, no doubt, belongs to the period of occupation of the fort,



Fig. 2. Secondary Hut abutting on Wall of Fort east of Entrance.

and may be the outcome of a tendency of the drain to flood in heavy rains. At a still later stage, when the fort was disused, a third floor has been roughly laid down at a height of 2 feet 3 inches above the covering of the drain. The northern side of the entrance passage wall was then reduced to this height and a small cell, as shown in Pl. I., had been constructed over the filled-up passage and in the thickness of the wall to the north of it. The south wall of this cell is provided by the upper courses of the original south wall of the passage; the north wall is formed by a revetting, by stones laid horizontally and on edge, of the internal material of the fort wall. At its eastern end, over the passage, the cell is completed by rough walling. The maximum height of this cell above its floor is now about 2 feet.

Outside the fort, to the south of the entrance, is a hut of some size built against the fort wall but not bonded into it (Pl. I. and fig. 2). The outer part of this is now reduced to a single course, but its inner wall,

which abuts on the fort wall and is tolerably well built, stands to 2 feet above the floor. This is of compacted earth except for a roughly paved area near the door. This hut must have been constructed at a date when the fort wall was to some degree masked by fallen debris.

Underlying the floor of this cell, and extending to the area outside the fort entrance, is a burnt floor composed of layers of red and yellow peat ash. Peats giving both red and yellow ash are found in the island. No hearth was discovered, and the presence in the floor of a few pottery fragments and two pieces of pumice is insufficient evidence of the use to which this area was put. Bones are so ill-preserved in the peat that their absence is inconclusive, and it is not impossible that the floor may have been used for cooking purposes. The presence of successive layers of peat ash of different colours makes it unlikely that their cause was an attack on the fort entrance with the aid of fire.

#### THE STRUCTURE OF THE TOMB.

*Internal Structure.*—Internally the tomb is divided by septal slabs into five sections (numbered I. to V. in Pls. I. and II.) and a portal section



Fig. 3. Section I. of Chamber looking south. An abutment of the missing north Wall, P. 5, is seen in the middle foreground. The base of the displaced Pillar is on the left in Section II. To the right of it, resting upright against the end of P. 8, is the small slab which formed the east end of the Cist.

(numbered VI.) which lies to the east of the outermost septal slab, but within the wall orthostats P. 1 and P. 11. The term "section" is here

used as an impartial one involving no theory as to the purpose of the several parts. Section I. (figs. 3 and 4) is 7 feet in mean width; the north wall has been stolen, but its position was defined by the large block shown in Pl. I., which formed an external abutment and was itself packed to the north and west with smaller blocks, and by a sharp change in the colour of the soil. Section II. (fig. 4) is trapezoid, narrowing from

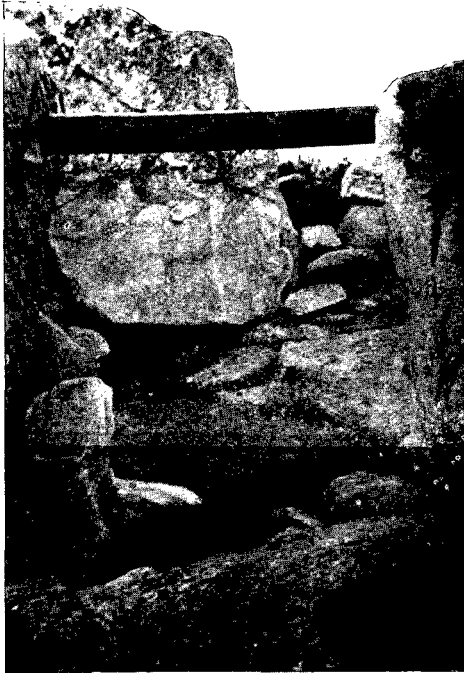

Fig. 4. Sections I. and II. of Chamber looking west from Section III. S. 2 in foreground, S. 1 collapsed and removed, Pillar displaced and lying on left in Section II. Solid rock-shelf on right in Section I. on which the missing north Wall, P. 5, stood.



Fig. 5. Section III. of Chamber looking east from Section II. S. 2 in foreground, S. 3 behind. The displaced Pillar lies on the right in Section II.

the width of the first to that of the remaining sections (figs. 5 and 6), of which the mean width varies from 4 feet to 3 feet 6 inches at floor-level. The portal area, section VI., is slightly over 3 feet wide and 1 foot 6 inches long. The heights of the sections, as measured from the rock-floor to the top of the wall orthostats, diminish from 7 feet in section I. to 5 feet in section II. to 4 feet 6 inches in section V. As measured from the original floor, the heights diminish from 6 feet 3 inches in section I. to 4 feet 9 inches in section II. to 4 feet 3 inches in section V.

The walls of each section are composed of single orthostats of gneiss supported either directly on the solid gneiss floor or on blocks or slabs laid upon that floor. While the walls of section I. slope slightly outwards, the walls of the other sections slope inwards, being supported at one end of the section by overlapping the walls of the next section and at

the other by a septal slab. These septa are formed by slabs of gneiss, in most cases irregularly shaped, and completed or supported at one end by blocks set upon the floor. S. 3 was doubled; a large slab stood vertical upon the floor and in contact with the true septum which took the pressure of the wall orthostats (fig. 6).<sup>1</sup> The height of the septa above the floor varied from 2 feet 6 inches to 1 foot 6 inches. The south wall of section IV. (P. 10) and the corresponding septum (S. 4) were missing; owing to the rise of the rock-floor the former had been a relatively small orthostat within the capacity of the fort builders to remove, while the latter had disintegrated into fragments and piles of grit. The septum S. 1 was only slightly less rotten, and disintegrated into fragments shortly after the filling was removed and before a photograph was taken.



Fig. 6. Sections I., II., and III. of Chamber looking west from Section IV. S. 3 in foreground. The south Wall of Section IV., P. 10, is missing; the north Wall, P. 2, is heavily tilted and supported on the dry masonry inserted by the excavators and seen at bottom right.

The natural rock-floor of gneiss is very irregular in level. Its hollows are filled with a fine, greenish clay, which, except where it was necessary to provide a foundation for an orthostat, the builders of the tomb had not disturbed. The chamber floor was the solid rock in the north parts of sections I. and II. and over the whole of section IV. The remaining parts of sections I. and II. were roughly paved with slabs lying on the clay. In section III. small slabs had been laid on the clay

<sup>1</sup> This second slab, if not an original and intentional feature, probably reached its present position early in the use of the tomb; I found no explanation of its purpose in which I feel any confidence.

at the western end and a few at the eastern end; supported on these two groups of slabs was a long, thin slab, running nearly the whole length of the section and leaving a cavity beneath it. As large parts of vessels were found beneath this it is possible that it was laid down after the original construction of the tomb. Similarly in section V. a large thin slab bridged a hollow filled with sludge and water, and below its level pottery was found. In section VI., the portal, a solid rectangular slab had been provided as a doorstep.

As will be seen from Pl. I. the axis of the chamber is not straight, but follows an ogee curve. The solid rock rises to the north of section I. and to the south of section V., and it might be argued that the axis makes a double curve merely to avoid these difficulties. It could, however, have been kept straight by orienting it slightly more to the north of east, which, so far as appears from the varying orientation of chamber tombs, was open to no religious objection. It seems reasonable to suppose, therefore, that the double curve in the axis was a foreseen and intentional feature.<sup>1</sup>

No roofing remains. A considerable number of slabs between 2 inches and 4 inches thick were found in the upper part of the filling, and these might represent remains either of barrel vaulting material or of dry walling used to level the tops of the orthostatic walls. No slabs long enough to bridge section I. were found in the debris of the fort, but this negative evidence is not entirely conclusive as it can be shown from the forecourt that the fort builders broke up large slabs. Whether the original roof was a flat one, or a false barrel vault, must therefore remain in doubt; as regards section I. at any rate the latter supposition is on the whole the more likely one. Whichever type of roof it was the fort builders had very effectually removed it.

In the south-east corner of section I. was an arrangement of vertical slabs which suggested the walling off of that corner.<sup>2</sup> A thin rectangular slab stood at right angles to P. 7 and resting against the end of P. 8; though not fixed its position was probably original (fig. 3). Parallel to P. 7, and 1 foot 9 inches from it, a slab stood vertically to a height of 1 foot above the slab flooring and fixed in it. A third slab, not fixed in the slab flooring, stood resting against and in line with the last, and approximately filled the gap between it and the slab which rested against P. 8.

<sup>1</sup> This is confirmed by a similar twisted passage in the chamber tomb of Unival, four miles to the south-east of Clettraval, which is now in course of excavation. This tomb shows marked similarities to, and no less marked differences from, Clettraval.

<sup>2</sup> This feature is confirmed by the existence of an elaborately made cist of slabs in the corresponding position in the chamber of the Unival tomb referred to in the preceding note.



In section II. a pillar, 4 feet 6 inches long and approximately 1 foot square in section, was found lying diagonally with its base on the rock-floor on the north side of the section and its head on the septum S. 2 (Pl. I. and fig. 5). Examination of its position showed that it could not have fallen from above, and I am satisfied that it originally stood upright in the north-west part of the section where its base was found. No wedging blocks were at its foot, but these would not be required to maintain it upright as its base was flat and at right angles to its axis.



Fig. 7. The south Façade looking south. The entrance to the Chamber, orthostats P. 1 and P. 11, is seen on the right. Q. 1 is in the centre, and behind it are seen the remains of Q. 2 lying horizontal, Q. 3, Q. 4, and Q. 6. The partially excavated path up to the Portal is seen in the foreground.

Its height was 3 inches less than that of the level top of the south wall, P. 8.

*The Forecourt Façade.*—Of the façade to the forecourt only the southern half now remains. This is a wall of great orthostats declining in height from north to south, the most northerly being 9 feet high (fig. 7). With the exception of the southernmost, which was set very slightly forward, these orthostats had stood accurately in a line set at an angle slightly greater than a right-angle with the line of the axis of section V. of the chamber. Save for a fragment of dry walling filling in a narrow gap between Q. 2 and Q. 3 the façade remaining was wholly orthostatic. It is natural to suppose that the interval of 3 feet 6 inches between Q. 1 and the portal slab P. 11 was once filled by a low orthostatic or dry stone wall, but no trace of this remained as the cairn had

here been denuded by the fort builders to the solid rock, 6 inches above which Iron Age pottery was found.

None of the façade orthostats were found in their original positions, which were determined by the excavation of their emplacements. They had been supported by propping them almost vertical against massive abutments at the back and securing their feet at the front by blocks set in earth. The line of abutments behind the façade was cleared except behind Q. 4, and was found to consist of a wall of heavy blocks set accurately in line (fig. 8). Behind this were the large boulders of the cairn, and resting against these and above the wall of blocks were slabs of considerable size designed to wedge out the orthostats into an approximately vertical position. The blocks securing the feet of the orthostats at the front were found in position only in the cases of Q. 2 and Q. 6, which had tipped forward over them. So much of the former as remained lay horizontal; the latter lay with its head tilted downwards. The feet of Q. 1, Q. 3, and Q. 4 had slipped forward with the removal of the upper part of the cairn behind them. The small orthostat Q. 5, which filled the interval between its larger neighbours Q. 4 and Q. 6, was tipped forward and lay horizontal.

The collapse of the southern half of the façade had been brought about by the fort builders, no doubt in search of stone. They had removed the bulk of the cairn material behind the façade and had cleared the forecourt as far south as Q. 5 substantially down to floor-level. The bank which they had built in a north-easterly direction across the forecourt from Q. 4 was subsequent, though possibly immediately subsequent, to this clearing; only a short length was removed in the present excavations owing to the labour involved, but Iron Age pottery was found at



Fig. 8. Pit in which Q. 2 stood with abutments on the left. The remains of Q. 2 lie horizontal on the right. Q. 1 is seen top right lying tilted backwards over its pit.

its base. Except for this bank the forecourt was not filled in again by the fort builders, and its filling consisted of the peat which had formed in the hollow created by the bank (*cf.* section CD, Pl. II.). The only part of the southern half of the façade which had been removed by the fort builders was the upper part of Q. 2, which had been split horizontally.

The collapse of the façade had largely destroyed the paving of the forecourt in front of it. This had probably been in the nature of a path along the façade. It was found under Q. 6 and partially under Q. 2, these two orthostats having tipped forward over it. When the feet of Q. 3 and Q. 4 slipped forwards they had carried the paving with them, and overlapping slabs were found displaced in front of them. In front of Q. 1 and east of the present position of Q. 2 only isolated paving slabs were found complete, but many were discovered reduced to a layer of coarse grit.

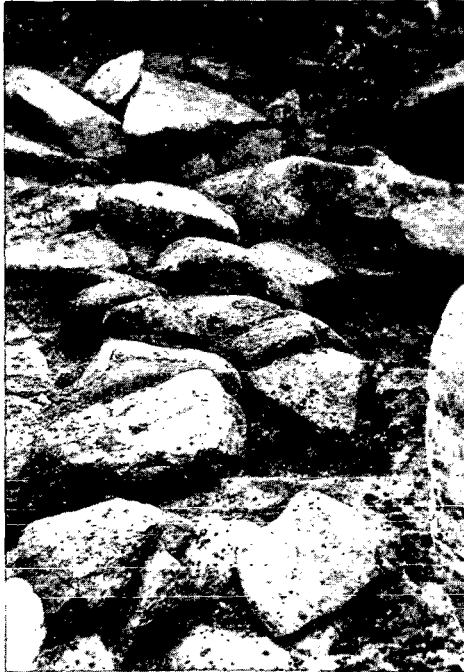

Fig. 9. The Path leading up to the Portal looking east from the Portal.

With the building of the Iron Age bank the forecourt had become a pond. Large areas of blood-red mud were found, six or more inches thick, and hard red accretions had formed on the remains of Q. 2 and on displaced paving slabs in front of Q. 3 and Q. 4. In some cases these slabs had been bound together by these accretions to such a degree that they could only be split apart with a pick. Specimens of this red matter were submitted to the late Dr H. H. Thomas, who recognised it as somewhat incoherent iron pan, a substance which forms in stagnant water, and the areas of red mud, specimens of which were examined in the laboratory of the British Museum, no doubt represented such stagnant pools. These conditions may have contributed to the disintegration of slabs composed of the more rotten elements of the gneiss into the layers of coarse grit already mentioned.

From the portal a solid path extended in the line of the axis of section V. of the chamber (fig. 9). This was composed of boulders set

in the clay overlying the solid rock surface, which, except for isolated bosses, sloped downwards to the east of the façade. Over these boulders was laid a rough layer of slabs, sometimes overlapping and up to 3 feet in length. The built path ceased 12 feet east of the doorstep, but a layer of slabs erratically laid on the earth continued 5 feet further.

The northern half of the façade was excavated for 15 feet north from the portal. Beyond that excavation offered no hope of results as the cairn had been wholly removed by the fort builders, and modern peat



Fig. 10. Abutments of northern Façade. Section of dry walling in front of Pick.

cutting must have destroyed any traces of orthostat emplacements below floor-level (*cf.* Elevation of Façade, Pl. II.).

The first façade orthostat was discovered fallen backwards and reduced to fragments. The stone had been an exceedingly rotten one, composed in part of granite elements in the gneiss which, like many paving slabs in the forecourt, had disintegrated into piles of coarse grit. Shovel-fuls of pure granitic grit were removed from places where this rotten part of the orthostat had lain. The remainder, composed of harder elements in the gneiss, had been shattered into splinters large and small. A large block sunk in the natural clay had served as a support at the front of the foot of this orthostat; and 2 feet 6 inches to the west of this was the line of blocks forming the abutment at the back (fig. 10). Piled-up slabs to the east represented paving displaced by the foot of the orthostat as it capsized.

Beyond this orthostat lay a short length of dry walling standing to a height of three courses. The next succeeding orthostat had been

removed after having been apparently tipped forward on its face. The line of its abutments remained, less massive than those of the southern half of the façade, but undisturbed (fig. 10). The paving, which had been laid in front of this orthostat, was found substantially undisturbed and extending to an approximately uniform width of 4 feet. On the west edge of this, immediately to the north of the dry walling, was a thin slab set on edge which had supported the foot of the orthostat at the front.

The line of the west edge of the pavement, which roughly corresponds with the line of the abutments, gives an approximate indication of the angle of the north half of the façade to the axis of section V. of the chamber and of the path leading to the portal. This angle is  $101^\circ$ , comparing with an angle of  $99^\circ$  in the case of the south half of the façade. While, therefore, the first orthostats to the north and south of the portal were not set symmetrically—possibly because the boss of solid rock to the west of Q. 1 rendered a nearer approach to the portal there impracticable—we have some reason to think that the northern and southern halves of the façade were generally symmetrical, each being set back from the forecourt axis some  $10^\circ$  more than a right angle.

*The Peristalith.*—The peristalith was excavated for a distance of 30 feet west from its termination at the south end of the forecourt façade. It was found to be a tripartite structure (fig. 11). Its inner element was a wall of massive blocks set on end; these were of varying shape and size, the average height being about 2 feet 6 inches. Outside and below this—for the hill here fell away rapidly—was a low wall of slabs laid horizontally with a level upper surface. The slabs composing it were generally thin and of moderate size; one much thicker and larger than the others was 4 feet long, 1 foot 3 inches wide, and 1 foot thick. The third and outermost element was a ramp of relatively small slabs tilted upwards and inwards, immediately against the second element.

The line of this section of the peristalith was straight, making an angle of  $10^\circ$  with the forecourt axis. Its eastern end was definite, the inner element ending immediately behind the original position of Q. 6 and its middle and outer elements ending some 5 feet to the east of this. Short trenches immediately to the south and south-west of the fort did not disclose any peristalith, but in this area it would almost certainly have been removed by the fort builders. The position which it should have occupied on the north of the chamber was occupied by peat cuttings, and here also it might well have been removed with the cairn material in building the fort. The south-eastern section, no doubt,

owes its preservation to being distant from, and at a lower level than, the fort.

The positive evidence for the original plan of the peristalith was thus limited to a 30-foot length of the south side. If this is typical, and the structure was generally symmetrical, the whole must have been



Fig. 11. Peristalith looking west from Q. 6. The inner wall of large blocks is on the right, the intermediate wall of flat slabs is to the left of this, and the outer ramp of tilted slabs is further to the left.

wedge-shaped in plan, tapering from its terminations at the ends of the forecourt façade towards the tail of the cairn.

The excavations already mentioned as having been commenced at the neighbouring chamber tomb of Unival suggest, however, that the assumption of symmetry may not be justified. Present indications are that the plan of the façade of that tomb will prove to be the same as that of Unival, and with the portal much to the right of the centre of the façade, while the peristalith will be found to follow a roughly circular plan. If that should be the case, it will be reasonable to infer that the façade of Clettraval extended no further than the northern limit of the excavations and of the present cairn, and that the peristalith ran thence

in a westerly direction, curving round under the eastern part of the fort.

*The Cairn.*—The material of the cairn where this remained was rounded boulders and irregular blocks and slabs of every size up to a hundredweight or more in weight. When excavated the interstices were entirely filled with earth, but this was probably due to denudation; the original shape may well have been steep-sided enough to prevent the accumulation of soil and the growth of vegetation.

The short trenches mentioned above as being cut immediately to the south and south-west of the fort disclosed Iron Age pottery and no indubitable cairn material, and boulders found underneath the wall of the fort may have been a foundation laid for that wall. The extent of the cairn to the east of the forecourt façade was not determined by excavation, and surface indications were wholly unreliable owing to the vicissitudes the site had undergone. The periphery was traced for short lengths at the west and east ends of the section of the peristalith excavated. At the west end it was 3 feet outside the outermost element of the peristalith; at the east end it was apparently beginning to curve round to the north.

The extremely limited evidence therefore points to a cairn originally wedge-shaped in plan with a straight or rounded eastern end overlying the forecourt.

#### DISTRIBUTION AND STRATIFICATION OF OBJECTS.

The objects found in the chamber were minute fragments of human and animal bones, sea-shells, an object of pumice, charcoal, and a remarkable wealth of pottery. Those found elsewhere were two granite objects, split pebbles of jasper possibly humanly struck, quartz pebbles, and considerable quantities of Iron Age pottery.

*The Chamber.*—The objects in the chamber were classified according to the section in which they were found and in three strata. The datum for recording stratification was the rock-shelf on the north side of section II. on which the pillar stood. Stratum A was from 2 feet above datum to the modern surface, the average level of which was 3 feet 6 inches; stratum B was from 1 foot to 2 feet above datum; stratum C was less than 1 foot above datum. Owing to the irregularities in the floor stratum C was in places more, and in other places less, than 1 foot thick.

The filling of the chamber below the turf consisted in stratum A of brown earth. From this there was a well-defined change in the upper part of stratum B to black material, which continued to the floor and

became generally more slimy as the floor was approached. Stratum C was generally free of fallen stones; stratum B contained a considerable number of slabs; in stratum A there were few slabs, but a number of rounded cairn stones.

With the exception of a single fragment on floor-level at the west end of section II. the bones were found in one small packet in stratum C in the middle of section I. What remained were minute fragments of calcined bones among white slime representing the last residuum of other bones. The complete or almost complete destruction of bone by the chemical action of the soil is a normal feature in Hebridean tombs.

Scores of winkle and limpet shells were found in stratum A in the middle of section II. in a single packet lying within a space not more than a foot in any direction. They are certainly not original deposits in the tomb, and in all probability represent a basketful of refuse thrown down by the inhabitants of the fort.

The pumice was in stratum C in the north-east corner of section I.

Charcoal was found throughout the black filling in strata B and C in all sections of the chamber except IV., but to a much greater degree in the lower stratum.

About forty pottery sherds were found in stratum A. With the exception of a very few, specified in the catalogue of pottery below (p. 500), which could be shown to belong to vessels represented by more numerous sherds in stratum B, this pottery was all assignable to the Iron Age. After the building of the fort the chamber must have appeared as a shallow trench a foot or more below the general level of the cairn surface, and it no doubt collected rubbish such as the shells referred to above.

Of the many hundreds of sherds found in strata B and C none need be, or indeed at all suggests being, of the Iron Age; all that are in any way determinate can be referred with fair certainty to the Neolithic and Beaker periods. The distribution of the vessels represented is shown in the table on p. 496.

It will be appreciated that the association of sherds together as belonging to the same vessel has been a matter of judgment, and can only be regarded as approximately accurate. In making the classification the number of cases of doubt was less than might have been expected, but a certain number of shaled-off and minute fragments had to be disregarded. Equally it has been a matter of judgment whether vessels should be classified as Neolithic or Beaker, and, where the number or character of the sherds was insufficient for a reasonably confident decision, they have been shown as "indeterminate." The merits of the classification can be tested to some degree by reference to the catalogue



given below and fully by examination of the sherds themselves, which are numbered and deposited in the National Museum of Antiquities, Edinburgh.

## VESSELS REPRESENTED IN STRATA B AND C.

		Sections of the Chamber.						All Sections.
		I.	II.	III.	IV.	V.	VI.	
Stratum B . .	Neolithic . . .	5	...	1	1	...	...	7
	Beaker . . . .	4	1	...	1	...	...	6
	Indeterminate	11	6	1	...	...	...	18
	Total . . . .	20*	7	2	2	...	...	31*
Stratum C . .	Neolithic . . .	3	2	3	...	2	1	11
	Beaker . . . .	...	...	...	...	...	...	...
	Indeterminate	1	...	2	...	...	...	3
	Total . . . .	4	2	5*	...	2	1	14*
Strata B and C.	Neolithic . . .	8	2	4	1	2	1	18
	Beaker . . . .	4	1	...	1	...	...	6
	Indeterminate	12	6	3	...	...	...	21
	Total . . . .	24*	9	7*	2	2	1	45*

The numbers marked with an asterisk indicate that not less than that number of vessels was represented.

It will be seen from the table that the total number of vessels represented is not less than forty-five, and all these may be regarded as original funerary deposits. That all the vessels represented were originally deposited whole is not necessarily to be assumed. It will also be seen that more than half the vessels were in section I. of the chamber; of the balance, diminishing numbers were in sections II. and III., only two each in sections IV. and V., and only one in the portal, section VI. As recorded in detail in the catalogue below, two vessels (II.B. 1 and V.C. 2) produced fragments in two contiguous sections of the chamber, and one (I.B. 3) in sections I. and III.

In stratum B seven determinate vessels were Neolithic and six Beaker. In stratum C eleven vessels could be classified definitely as Neolithic

and none as Beaker, while three were indeterminate. Of these last, only one, represented by a single sherd (I.C. 4), was at all likely to be other than Neolithic. Study of the pottery itself, therefore, gives no reason to doubt that the stratification represents the order of deposition of the vessels in any one section of the chamber. Comparison of one section with another would not be legitimate, as it cannot be inferred that the rate of accumulation of the filling in different sections was the same.

Examination of the filling of the chamber gave reasons to expect disturbance of the stratification only in two places. The northern edge of section I. was evidently disturbed by the removal of the north wall orthostat, P. 5, the black filling being replaced by brown soil along the line where this orthostat had stood. This disturbance did not, however, affect stratum C, since P. 5 had stood on a shelf of solid rock more than a foot above the floor of the section. Few sherds were recovered from this northern edge, and all were small.

Worse disturbance had occurred in section IV. when its south-wall orthostat, P. 10, was removed. The rock-floor rose high in this section, so that stratum C was hardly represented, and the filling consisted of brown earth and in considerable part of fallen slabs and cairn stones. Only four sherds were found, all in stratum B, and in a position which must originally have been occupied by the stolen south wall; three of them belonged to a Neolithic- and one to a Beaker-type vessel.

Making due allowance for this evidence of disturbance, I think that considerable reliance can be placed on stratification in sections other than IV. Stratum C was protected from disturbance by the considerable number of fallen slabs in stratum B. The fort builders, no doubt, trampled the latter heavily enough, but the funerary deposits even in that stratum were already well covered and were in all probability crushed rather than disturbed. In stratum C, and also, in the south part of section I., in stratum B, large parts of vessels were found intact. This does not of course exclude the ordinary disturbance to which chamber tombs are subject by the interference of later burials with earlier ones, but, if this had been serious, the number of cases of vessels of which sherds were found in two strata would have been much greater than the instances which actually occurred and are recorded in the catalogue below.

In section I. the great bulk of the sherds, and all the vessels of which large parts were found intact, were in the south and east parts of the section. In section II. the two fairly complete pots in stratum C were found on the north side, immediately east of the base of the pillar. In

section III. the sherds of the two restorable pots were found in the north-east and south-east corners. In section V. the vessel V.C. 1 was found, broken but nearly complete and not scattered, standing on a slab under the north wall and at a lower level than the large paving slab which spanned the floor.

*Other Parts of the Site.*—The two granite objects in the shape of flattened or faceted balls were found in the pit in which Q. 2 had stood.

Water-worn white quartz pebbles were found in a number of positions. Two such, one being split, were found on the top of the north wall of section IV. of the chamber. A split pebble was in the pit in which Q. 2 had stood, and two, unbroken, to the east of Q. 2 on the forecourt floor. One pebble was on the floor to the east of Q. 4 and one in the cairn to the west of it. Two pebbles, one of them battered, were found on the original ground-level at the junction of the peristalith with the southern façade. Numerous blocks of white quartz other than water-worn pebbles were found in the cairn material, but as these occur naturally in the gneiss, their presence was probably due to natural causes.

Iron Age pottery was found in the area of the fort excavated, in and under the Iron Age bank across the forecourt, and scattered thinly over the whole surface left when the cairn was denuded to build the fort. As there was a secondary occupation of the fort at a period when the original structure had fallen into decay, it would be very desirable to distinguish stratigraphically between the pottery belonging to the two periods.

The small area of the fort excavated gave, unfortunately, no stratigraphical evidence of value. The secondary structure to the south of the entrance forbids any inference that pottery found outside the entrance belongs to the period of occupation of the fort; the secondary structure over the entrance equally forbids any inference as regards the pottery found in the entrance passage or immediately within the entrance. Comparison of the fragments found in the passage respectively above and below the floor, which was laid down a foot above the slab-covering of the drain, show no distinction of type, and indeed this floor could not be regarded as effectually sealing the deposits below it. The drain might be expected to be sealed when the fort had fallen into decay and the secondary structures were built, but only one of the few fragments from the drain showed any distinctive features.

The only pottery from other parts of the site which was effectually sealed was the large deposit under the bank across the forecourt. This

bank does not extend south-west beyond Q. 4 and it dies away, so far as surface indications go, to the north-east. Its intention can hardly have been defensive. If a conjecture may be hazarded its purpose was to do that which in fact it did do, namely, to dam up water and form a pond; even in the, probably wetter, conditions now subsisting there is no natural and substantial supply of water in the neighbourhood of the fort. However that may be, it probably belongs, with the pottery underneath it, to the period of the fort's use.

Of the sherds found elsewhere on the surface of the cairn, as denuded by the fort builders, all that can be said is that they are more likely to belong to the period of intensive occupation when the fort stood than to that of the secondary occupation when it had already partially collapsed.

#### DESCRIPTION OF BONE FRAGMENTS.

The fragments of bone found in stratum C in section I. of the chamber were examined by Dr J. Wilfrid Jackson, and those which he considered as probably human were further examined by Miss M. L. Tildesley. The animal bones, which were calcined, were reported by Dr Jackson to be consistent with a small sheep or goat. Regarding the human bones Miss Tildesley reports as follows:—

“Two fragments can be definitely identified as human—the shaft of a metacarpal, and part of the left inferior articular surface of a vertebra (? 7th cervical)—and with one exception the other small fragments are quite consistent with a human derivation, being fragments of ribs, of shafts of long bones, of the cancellous tissue in the extremities of long bones, etc. The evidence of burning is quite clear, two fragments being blackened, and many of the others showing the kind of splitting characteristic of cremated remains. It is asked whether the condition of the bones suggests mere scorching, perhaps from purificatory fires lit in the grave. Since these fragments are split as thoroughly and in the same way as the fragments of bone from cremated bodies, one infers that they were not merely scorched, and if the burning was the result of a purificatory fire, this must have been lit immediately above the body and have consumed the parts here represented as effectually as a cremation would have done. Also it can be asserted that these were not mere dry bones when subjected to fire.

“The texture of many of these fragments, unlike that of most cremated remains, is quite chalky. Presumably this change must be attributed to the chemical content of the soil in which they were preserved.”

DESCRIPTION OF NEOLITHIC AND BEAKER POTTERY FROM CHAMBER.

*Section I.*

*Stratum B.*

*I.B. 1* (fig. 12).—Thirteen fragments, including two contiguous ones, of a vessel of a fairly fine paste, grey to buff in colour; thickness 5 mm.,

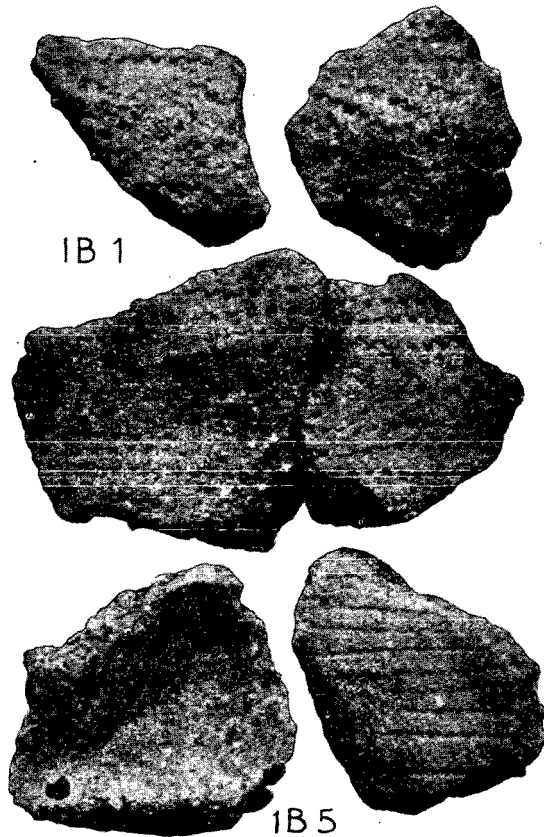

Fig. 12. Vessels *I.B. 1* and *I.B. 5*. (†)

increasing to 9 mm. at the shoulder. The vessel had a thickened and slightly angular shoulder, at which the diameter is about 14 cm. It is decorated with at least two bands, one of which has its centre line on the line of the shoulder. Each consists of one row of fairly widely spaced horizontal chevrons between parallel lines. All the decoration is formed

by light impressions of a shell. Experiment shows that a small cardium shell can be used so as to give such impressions.

*I.B. 2* (fig. 21).—Fragment of beaker of moderately fine grey paste having a dark grey burnished outer surface; thickness 6 mm. Decorated with two groups of horizontal lines deeply incised with a fine-pointed instrument, and between these a band of close diagonal lines impressed with a fine comb.

*I.B. 3* (figs. 13 and 36).—Numerous fragments of a somewhat anomalous beaker of which the upper half has been restored and the profile conjecturally reconstructed. The paste is dark grey, fairly fine,



Fig. 13. Vessel I.B. 3. ( $\frac{1}{2}$ .)

with fine grit; the thickness is 7 mm. The decoration, starting from the base, consists of a band of seven horizontal grooves, a band of large chevrons formed of very shallow grooves, another band of horizontal grooves, two lines of dots at the greatest diameter of the vessel, another band of horizontal grooves, a narrower band of very shallowly grooved chevrons, seven horizontal grooves, and, on the lip, curving lines running upward impressed with a cardium shell. The top of the rim, which is flat, is decorated with close diagonal impressions of a similar shell. Other fragments of this vessel were found in stratum A in section I., and in stratum B in section III.

*I.B. 4* (figs. 14 and 36).—Three rim and two other fragments of dark grey paste, moderately coarse; thickness 12 mm. The rim is flat; below it there are three parallel incised lines. Lower on the vessel is a band of horizontal lines, deeply incised with a square-pointed instrument, joined by diagonal lines or chevrons.

*I.B. 5* (figs. 12 and 36).—Eight fragments of fairly fine paste, grey to buff in colour, 9 mm. thick. Decorated with parallel lines irregularly



Fig. 14. Vessel I.B. 4. (†.)

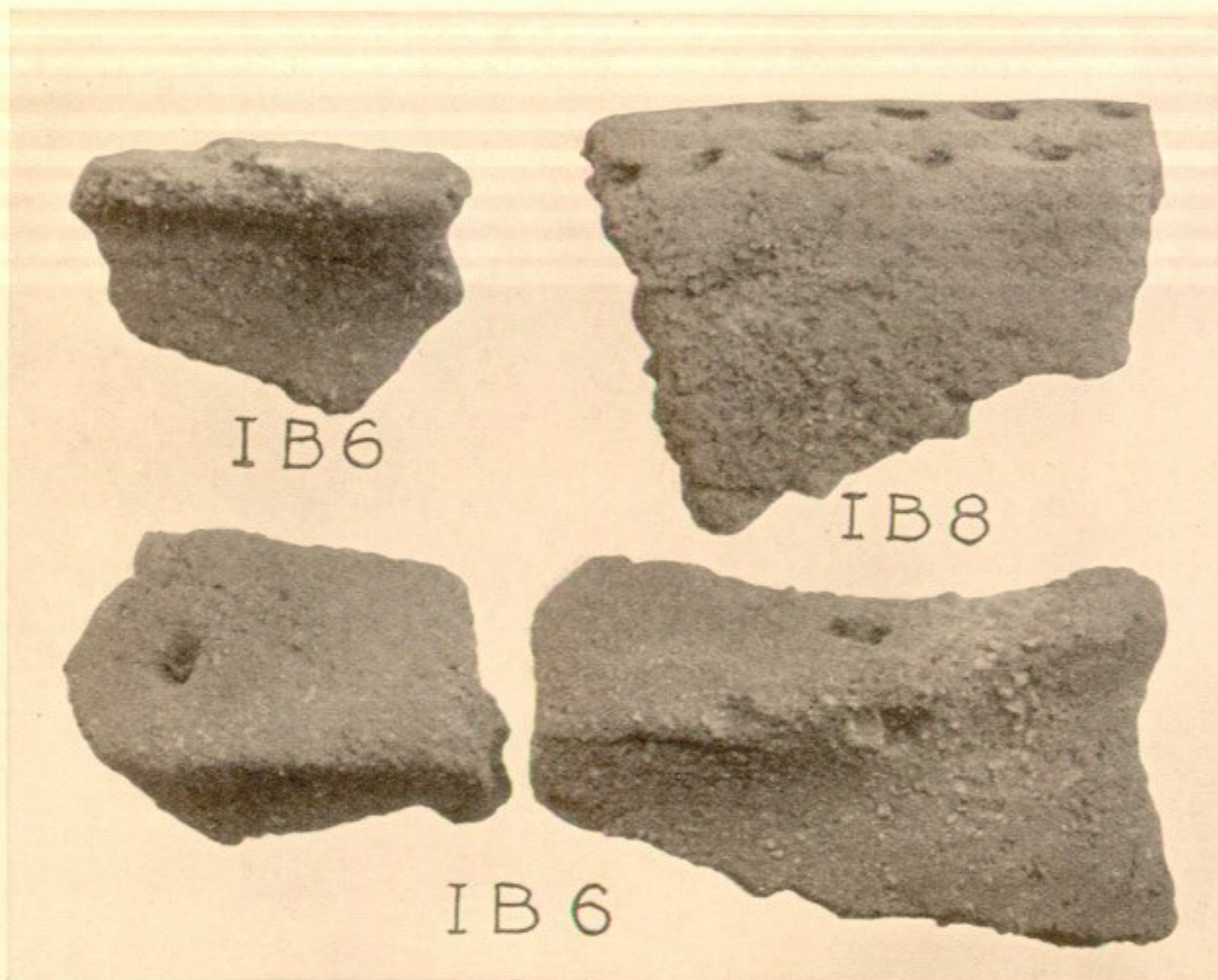

Fig. 15. Vessels I.B. 6 and I.B. 8 (interior). (†.)

incised with a fine instrument. A fragment of flat base probably belonging to this vessel shows a group of vertical chevrons above the distinct foot, from which the wall of the vessel spreads out widely. Four of the fragments were found in stratum A.

*I.B. 6* (figs. 15 and 37).—Rim, shoulder, and other fragments of fairly fine grey to drab paste mixed with a great quantity of fine grit. Thickness 6 mm. The vessel was a small one, with a sharp and thickened shoulder and a flattened ledge rim. One shoulder fragment shows a roughly vertical perforation through the much thickened keel; another shows what appears to be an uncompleted vertical perforation. The vessel is undecorated except for faint finger-tip fluting diagonally on the upper surface of the rim.

*I.B. 7* (figs. 16 and 38).—Very numerous fragments of a large vessel of coarse buff paste, verging in parts into brick red and blackened on parts of the interior; thickness 8 mm. The vessel is round-bottomed. The division between the body and the neck is marked by an irregularly pinched-out cordon of V-section. The diameter at this level is about 16 cm. Above this the neck begins vertically and then slopes outward to the rim, which is steeply bevelled internally. The cordon is decorated on its upper side by deep diagonal stabs, the neck by lines deeply incised with a sharply pointed instrument and curving upwards and to the left. The inner bevel of the rim is incised with two rows of irregular diagonal strokes, the strokes in the lower row sloping in parts in the same direction with, in parts in the opposite direction to, those in the upper row. There are indications of a horizontal lug now sheared off at one part of the cordon. Some of the fragments were found in stratum C.

*I.B. 8* (figs. 15 and 37).—Numerous fragments, including the complete bottom and three rim fragments, of a vessel of fairly coarse gritty paste, grey to drab in colour but verging to putty colour on the outside and considerably blackened inside; thickness 7 mm. The vessel is round-bottomed; there is no trace of any shoulder, and the neck slopes outwards. The rim, which has a diameter of about 17 cm., is thickened, rounded on its outer side, and bevelled on its inner side. This bevel is decorated with two horizontal rows of short stabs; otherwise the vessel is plain.

*I.B. 9* (figs. 17 and 38).—Vessel (restored) of fairly coarse grey paste, reddish in places and mixed with large grit. From a round bottom the wall curves round to the vertical at a sharp shoulder, above which it curves inward to form a slightly hollow neck. The rim is slightly everted and bevelled internally. Height 17 cm., diameter at shoulder





Fig. 16. Vessel I.B. 7. ( $\frac{1}{3}$ .)



Fig. 17. Vessel I.B. 9. ( $\frac{1}{3}$ .)



Fig. 18. Vessel I.C. 1. ( $\frac{1}{3}$ .)



Fig. 19. Vessel I.C. 2. ( $\frac{1}{3}$ .)

17·5 cm., at rim 16 cm. Decorated on neck with sets of short horizontal stabs placed vertically or in irregular diagonals.

*I.B. 10* (fig. 37).—Minute fragment of a flattened rim of fine grey paste.

*I.B. 11*.—Small fragment of fairly fine grey paste, buff on outer surface, 7 mm. thick, showing fine shallowly grooved parallel lines.

*I.B. 12* (fig. 37).—Rim fragment of fairly coarse paste, greyish buff on the surface and dark grey within. From a thickness of 6 mm. the wall thickens and slopes outward to a flattened rim 10 mm. in width.

Twenty-nine other fragments, representing not less than eight vessels, including one flat-bottomed vessel, were also found in this stratum. Three minute fragments showed incised decoration, and one decoration with shallow grooves.

#### *Stratum C.*

*I.C. 1* (figs. 18 and 38).—Vessel (restored) of moderately coarse paste, generally grey in colour but verging to buff at parts of outer surface, which in the neighbourhood of the shoulder shows signs of burnishing. Height 9·5 cm., diameter at rim 10·5 cm., at shoulder 11·5 cm. Thickness 7 mm. From a round bottom the wall curves regularly, reaching the vertical at the sharp shoulder, from which it curves inwards to form a hollow neck and then outwards to the rim. The rim is slightly thickened and everted. The decoration is formed by long shallow curvilinear grooves. These reach from the shoulder nearly to the bottom, forming groups of parallel curves set diagonally, successive groups round the vessel being in opposite directions. The neck is similarly decorated with groups of parallel curves set diagonally, successive groups being in opposite directions. The fragments of this vessel were found vertically under those of *I.B. 7*.

*I.C. 2* (figs. 19 and 38).—Vessel (restored) of fairly coarse grey paste, verging to brick red on parts of the outer surface. The outer surface shows burnishing. Height 17·5 cm. Diameter at rim 19 cm. Thickness 7 mm. From a round bottom the wall curves regularly until reaching nearly the vertical, and thence is straight. 2 cm. below the rim is a large horizontally set lug at one side of the vessel; on the opposite side the outer surface is shaled off where a corresponding lug has been. Just below and to the left of the lug the wall is pierced by a hole tapering from the outside, the section being oval, 5 mm. by 4 mm. The hole was bored after firing. This may be a mending hole, but on the opposite side there is an irregular cavity which conceivably represents an incomplete corresponding hole. At the level of the lug the wall is slightly thickened. The rim is very slightly incurving and is rounded over. Undecorated.

*I.C. 3* (fig. 37).—One minute rim fragment, one shoulder fragment, and two other small fragments of moderately fine dark grey paste. Thickness 5 mm. The rim slopes outwards and is not thickened. The wall curves inwards very sharply at the shoulder, which shows a diameter of about 10 cm. Undecorated.

*I.C. 4*.—Fragment and some minute fragments of fairly fine paste, grey within and buff on both surfaces; the outer surface is much burnished and blackened in places. Thickness about 8 mm. Undecorated.

*Stratum B.*

*Section II.*

*II.B. 1* (fig. 20).—Eighteen fragments of fairly coarse dark grey paste, buff externally; average thickness 8 mm. The incised decoration is



Fig. 20. Vessel II.B. 1. (4.)

formed of small chevrons arranged in bands and divided by groups of horizontal lines. There was a plain band round the belly of the pot. One fragment found in section III., stratum B.

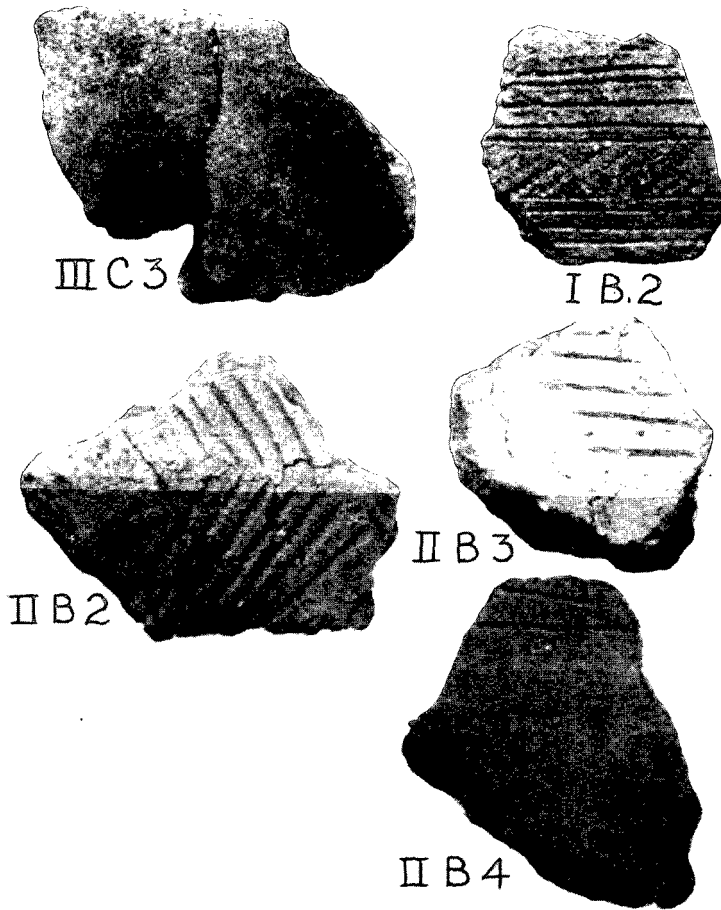

Fig. 21. Vessels I.B. 2, II.B. 2, II.B. 3, II.B. 4, and III.C. 3. (†.)

*II.B. 2* (fig. 21).—Three contiguous fragments of a vessel of fairly coarse grey paste, buff on outer surface; average thickness 11 mm. Surface burnished and decorated with bold parallel chevrons formed by deep grooves.

*II.B. 3.* (fig. 21).—Fragment of fairly coarse grey paste, 10 mm.

thick. Outer surface covered with buff slip and decorated with short parallel grooves.

*II.B. 4* (fig. 21).—Fragment of fine grey paste, buff externally; thickness 8 mm. Plain except for two fine incised lines across one corner.

*II.B. 5*.—Fragment of moderately coarse paste, buff outside and black within, 7 mm. thick. Decorated with irregular lines incised with a fine instrument.

*II.B. 6* (fig. 22).—Fragment of coarse reddish paste, grey externally,

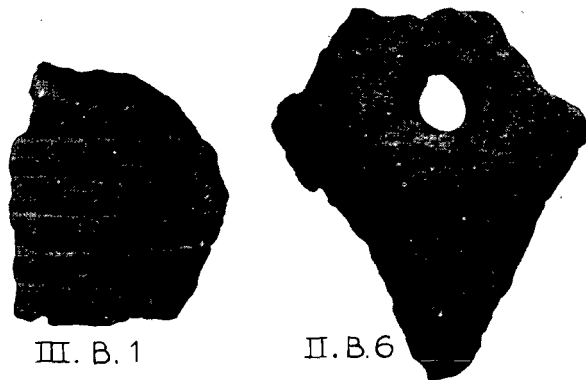

Fig. 22. Vessels *III.B. 1* and *II.B. 6*. (†)

badly shaled off; apparently part of a sharp shoulder sloping inwards above; pierced through just above shoulder by an oval hole 7 × 5 mm. tapering inwards.

*II.B. 7*.—Small fragment of fine paste, light buff in colour, 5 mm. thick. Decorated with parallel finely incised lines.

*Stratum C.*

*II.C. 1* (figs. 23 and 38).—Bowl (restored) of coarse paste, grey to reddish drab in colour, mixed with coarse grit and stones. Height 15 cm., diameter across mouth 16·5 cm., thickness of wall 7 mm. From a round bottom the wall diverges slightly and then curves more sharply outwards to form the shoulder. Above the shoulder the wall curves inwards to form a hollow neck, and then curves out again to a slightly thickened rim bevelled outwards. The hollow neck is decorated with a band composed of sets of vertical, alternating with sets of horizontal, lines irregularly incised with a sharp instrument.



Fig. 23. Vessel II.C. 1. ( $\frac{1}{2}$ .)



Fig. 24. Vessel II.C. 2. ( $\frac{1}{2}$ .)

*II.C. 2* (figs. 24 and 38).—Bowl (restored) of thin and moderately fine paste, dark grey to buff in colour. Height 12 cm.; diameter at rim 11.5 cm.; thickness at rim 5 mm. From a round bottom the wall curves to the vertical at a sharp shoulder, from which it bends sharply inwards to a slightly convergent neck. The thin rim is in line with the neck and is rounded on the top. The vessel is decorated from rim almost to its base with horizontal grooves very deeply cut in the upper part and less deeply in the lower part. Some irregular strokes are drawn diagonally below the lowest horizontal groove.

*Section III.*

*Stratum B.*

*III.B. 1* (fig. 22).—Fragment of fine, hard grey ware, 5 mm. thick. Decorated with a horizontal band of five broad and very shallow grooves,



Fig. 25. Vessel III.C. 1. (½.)

from the upper edge of which a set of five parallel narrow grooves strike upwards diagonally.

*III.B. 2* (fig. 37).—Rim fragment of somewhat gritty grey ware,

8 mm. thick but thinning towards the rim, which is simple with a slight internal bevel.

*Stratum C.*

*III.C. 1* (figs. 25 and 39).—Vessel (restored) of coarse paste. The inner surface is grey; the outer surface is grey in the upper part of the vessel, reddish and considerably shaled off in the lower part. Height 22.5 cm.; diameter at rim 21–22 cm.; thickness at rim 9 mm. From



III C 2

Fig. 26. Vessel III.C. 2. (½.)

a round and somewhat pointed base the wall curves outwards to a thickened shoulder, above which the hollow neck flares outwards to a simple rim slightly bevelled externally. The thickened shoulder expands into a long horizontal lug, and on the opposite side of the vessel are indications of a similar lug. The lower part of the vessel is plain. The thickened shoulder and the lug are decorated on their upper surface with a row of large circular pits; the flat bevel of the rim is decorated with similar but smaller pits. The hollow neck is decorated with wide grooves curving upwards and to the left round three-quarters of the periphery; round the remaining quarter the grooves are narrower and deeper and run vertically upwards or to the right. An accurately circular hole 3 mm. in diameter has been drilled (after firing) through the hollow neck in a place where it interferes with the decoration, and another has been partly drilled close alongside it.



*III.C. 2* (figs. 26 and 39).—Vessel (restored) of coarse, gritty paste baked hard. The colour is grey internally and grey to red externally. Height, 17·5 cm.; diameter at rim, 17·5 cm.; thickness at rim, 12 mm. From a round base the wall curves upwards to a slight shoulder above which is a hollow neck curving out to a thickened rim with a slight internal bevel. The vessel is markedly unsymmetrical. The only decoration is on the flat, internal bevel of the rim, and consists of a double row of faint jabs in one part and of short diagonal strokes in another.

*III.C. 3* (figs. 21 and 37).—Two contiguous rim fragments of fine smooth paste, buff in colour but blackened in places. Thickness 5–6 mm. The fragments have been part of a small bowl with walls curving outwards to a simple, thinned rim.

Twenty-one other fragments belonging to at least two vessels were also found in this stratum.

*Section IV.*

*Stratum B.*

*IV.B. 1* (fig. 27).—Two contiguous and one other fragment of fairly fine paste mixed with a quantity of fine grit, black internally and on

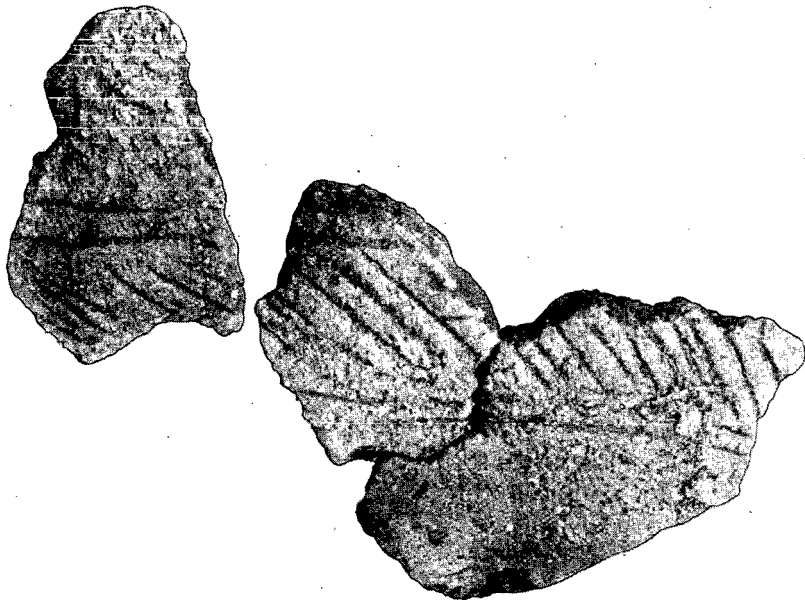

Fig. 27. Vessel *IV.B. 1*. (†.)

inner surface, dark buff on outer surface. Thickness 5–7 mm. These appear to have been part of a small shallow bowl. This has been surrounded by a band defined above and below by two incised lines, and filled by parallel incised lines set diagonally. There are faint indications of similar diagonal lines above the band.

*IV.B. 2.*—Base fragment of fine paste with smoothed surface, greyish brown in colour, 7 mm. thick. This has been part of a flat base from which the wall of the vessel spread out widely. Undecorated.

*Section V.*

*Stratum C.*

*V.C. 1* (figs. 28 and 39).—Deep bowl (restored) of coarse ware reddish to grey in colour and shaled off in parts. Height, 14·5 cm.; diameter



Fig. 28. Vessel V.C. 1. ( $\frac{1}{2}$ .)

at rim, 13 cm.; thickness at rim, 6 mm. From a round and slightly pointed base the wall curves to a slight shoulder, set above the greatest diameter, above which is a markedly hollow neck curving out to a thin and much everted rim. The round bottom is plain. The belly is decorated all over with long, deeply incised strokes set in lines sloping

downward to the right. The neck is decorated with similar strokes, but set in lines sloping downward to the left, except in a small part of the periphery where they slope downwards to the right. The interior surface of the rim is decorated with similar long strokes set diagonally.

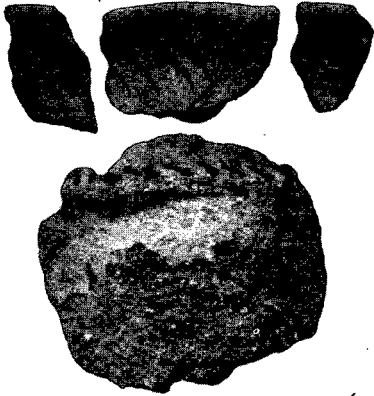

Fig. 29. Vessel V.C. 2. ( $\frac{2}{3}$ .)

hollow neck and outwards again to a slightly thickened, rounded rim. The shoulder is decorated with diagonal stabs on its upper surface and the neck, with incised curvilinear lines set in two or more groups alternately sloping diagonally to the left and the right. Three fragments were found in section VI.

#### Section VI.

##### *Stratum C.*

VI.C. 1 (figs. 30 and 37).—Contiguous rim and neck fragments of moderately coarse paste, dark grey externally and buff internally; thickness 6–7 mm. Diameter at rim about 12 cm. The neck is straight, sloping outwards to a broad ledge rim. The neck is decorated with a band of parallel, diagonal grooves, above which are two horizontal grooves. The flat top of the rim is decorated with close, parallel grooves set diagonally.

V.C. 2 (figs. 29 and 39).—Substantial part of a vessel of coarse paste mixed with much grit but smoothed on the outer surface. The colour varies from dark grey to dark buff. Thickness of neck 6 mm.; of lower part 7–8 mm. From a round base the wall curves round to a straight wall sloping outwards to the thickened shoulder at which the diameter of the vessel is about 15 cm. Above this the wall curves inwards to a



Fig. 30. Vessel VI.C. 1 with decoration on top of Rim shown above. ( $\frac{1}{3}$ .)

## DESCRIPTION OF STONE OBJECTS.

*Granite* (fig. 31).—Two objects of fine-grained granitic rock, possibly from a vein in the gneiss, were found in the pit in which Q. 2 stood. One is in the shape of a flattened ball, 8 cm. in diameter and of a maximum thickness of 5.5 cm. Its upper and lower faces, which are only slightly rounded, are smoothed; the remainder of its surface is roughened, as a

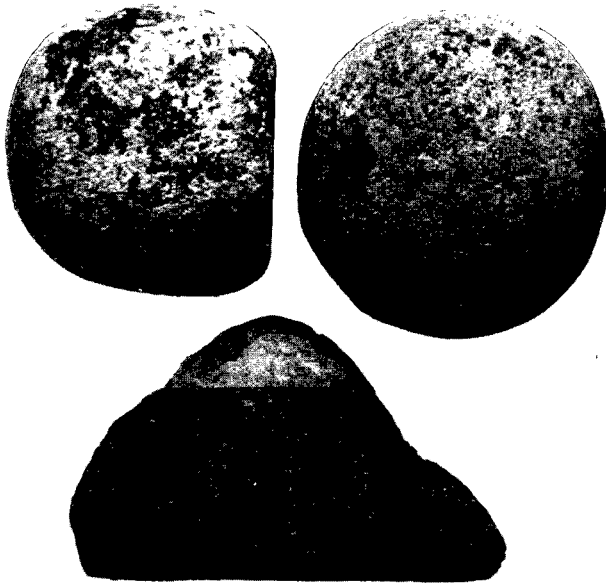

Fig. 31. Objects of Granite from Forecourt (above) and of Pumice from section I., stratum C, in Chamber (below). (Approx.  $\frac{1}{2}$ .)

result of battering. The other has a slightly hollowed base and two slightly flattened sides parallel to one another and at right angles to the base, but otherwise approximates to a sphere of about 7 cm. in diameter. The base is smoothed, and there are signs of battering in places elsewhere.

*Pumice* (fig. 31).—A piece of pumice 10.5 cm. by 8 cm. by 7 cm. high was found 6 inches above the floor in section I. of the chamber. Its base is rubbed flat; its irregularly rounded upper surface conveniently fits the hand for use in rubbing.

*Jasper*.—Several pebbles of ferruginous jasper, possibly humanly broken, were found in the forecourt to the east of Q. 2.

*Quartz*.—A large pebble of white quartz, heavily battered at one end

and slightly battered at the other, was found on ground-level at the junction of the south façade with the peristalith.

#### DESCRIPTION OF IRON AGE POTTERY.

It is not proposed to attempt a detailed description of the great quantity of Iron Age pottery found. Only a small number of the fragments were decorated or gave any indication of profile. The vessels

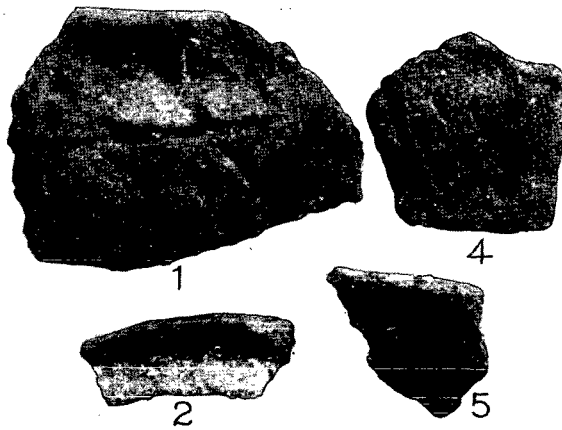

Fig. 32. Iron Age Pottery from bank across Forecourt. (3.)

represented varied from large pots, up to  $\frac{3}{4}$  inch thick, irregularly made of coarse clay mixed with great lumps of quartz, to well-made vessels, as little as  $\frac{3}{16}$  inch thick, of paste mixed with fine grit and in some cases well smoothed externally. Some of the coarse vessels have been built up in rings.

The distinctive types of decoration, and of rim and base section, are shown by the thirty vessels illustrated in figs. 32-35 and 40 and numbered 1-30. Of these vessels Nos. 1-7 come from the bank across the forecourt, Nos. 8-10 from stratum A of the chamber, Nos. 11 and 12 from the cairn surface as denuded by the fort builders, and Nos. 13-30 from the fort itself. Attention is called below to the principal types.

No. 1 (figs. 32 and 40) from the bank represents a type of vessel found also in the fort in No. 16 (figs. 34 and 40) and No. 17 (fig. 34). These vessels, which are crudely made, have vertical bulging necks and markedly everted rims. They are decorated round the neck with a band of large incised triangles, and immediately under the rim with a

CHAMBERED CAIRN OF CLETTRAVAL, NORTH UIST. 517

line of jabs. In No. 1 these jabs invade the band of triangles. No. 4 (fig. 32) from the bank probably comes from the neck of a vessel of the same type, and here the jab decoration is still more prominent.

No. 2 (figs. 32 and 40) from the bank represents a type of rim of which

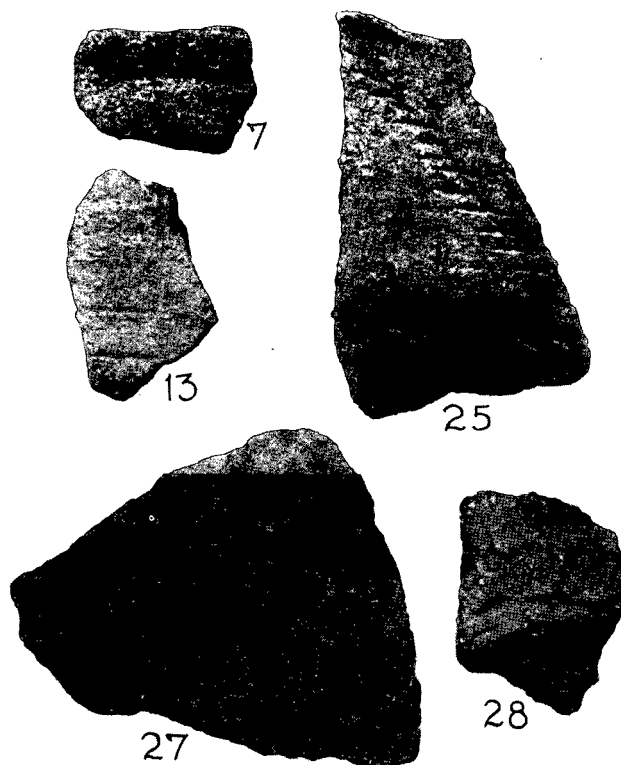

Fig. 33. Iron Age Pottery from the bank across the Forecourt (No. 7); from the Fort drain (No. 13); from the Fort entrance passage (Nos. 25, 27, and 28). (1.)

two other fragments were found in the bank, the number of vessels represented being at least two. From a thin neck the rim spreads out widely both internally and externally, and its upper surface is hollowed along its length. This hollow is decorated by a line of pin-pricks.

No. 5 (figs. 32 and 40) from the bank is a fragment of a similarly thickened rim, but its upper surface is approximately flat and is undecorated.

No. 6 (fig. 40) from the bank is a small fragment of an externally

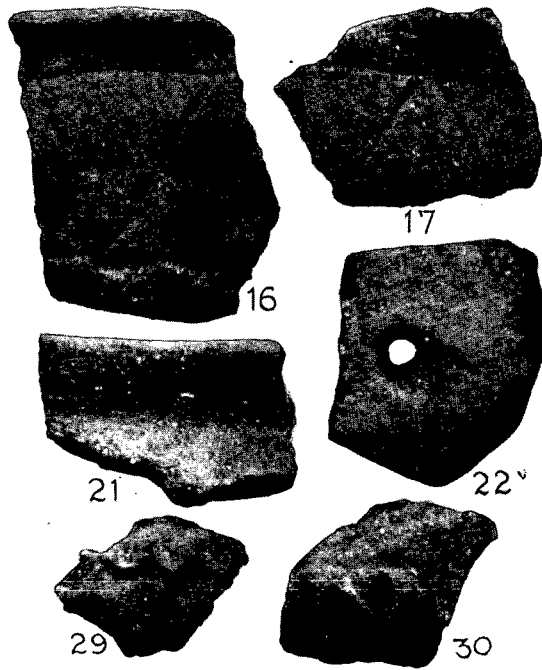

Fig. 34. Iron Age Pottery from Fort. Nos. 16, 17, and 22 from entrance passage; No. 21 from exterior; Nos. 29 and 30 from interior. (f.)

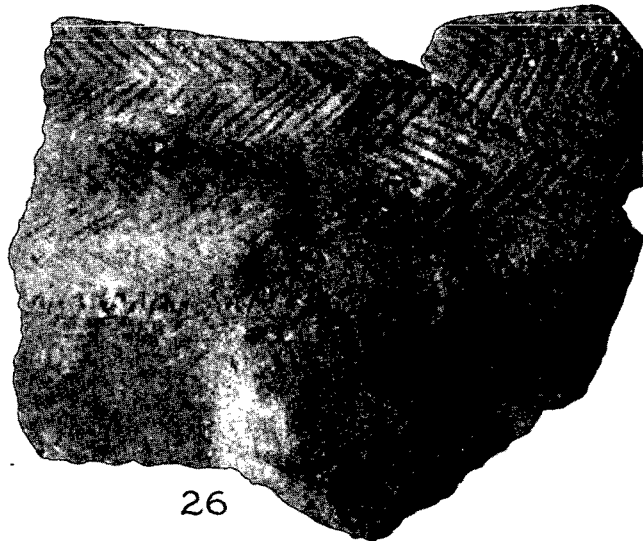

Fig. 35. Iron Age Vessel (No. 26) from interior of Fort. (f.)

CHAMBERED CAIRN OF CLETTRAVAL, NORTH UIST. 519

bevelled ledge rim, which is common in Neolithic pottery, and may in fact be Neolithic.

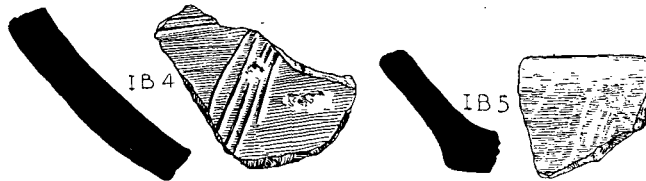
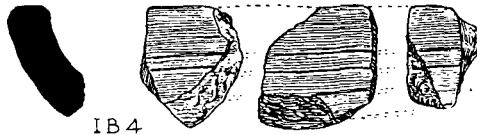
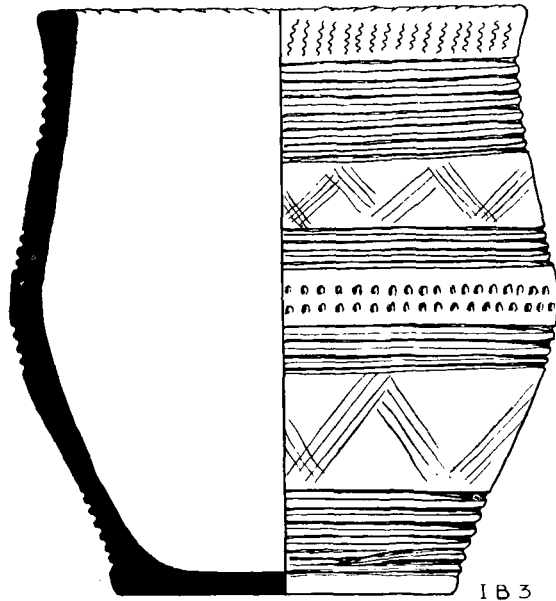

Fig. 36. Pottery from Chamber. (1.)

No. 7 (fig. 33) from the bank is a small fragment with incised decoration, which is probably of the same general type as Nos. 1, 16, and 17 described above.

No. 8 (fig. 40) from stratum A of the chamber (section IV.) is a type of rim with a heavy and somewhat hollow internal level, which



is represented also by a fragment from the bank. No. 8 is decorated on the outside with vertical incised lines.

No. 9 (fig. 40) from stratum A in the chamber is a fragment of a thick vertical neck thinning to a simple rounded rim. The type is represented again by No. 15 (fig. 40) from the entrance passage of the fort.

No. 13 (fig. 33) is the only distinctive fragment from the drain through

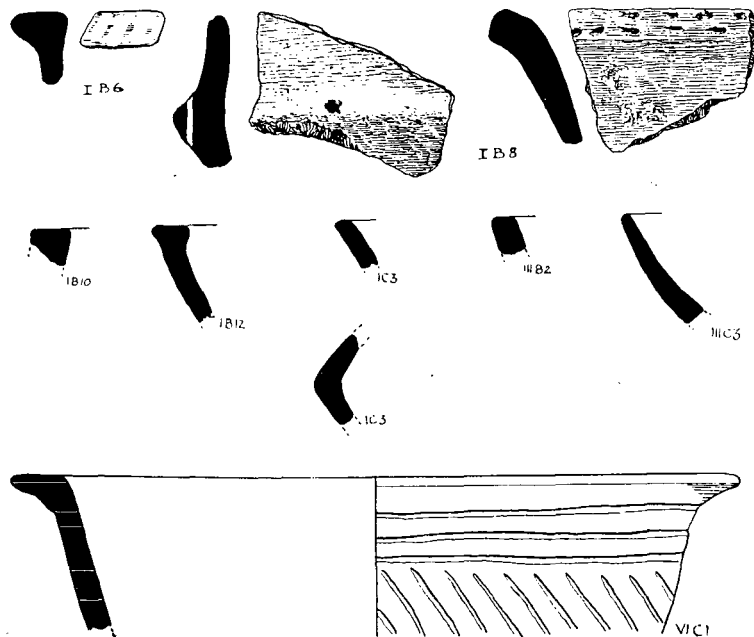

Fig. 37. Pottery from Chamber. ( $\frac{1}{2}$ .)

the fort entrance. It is a thin fragment of fairly fine, light grey paste, with a pattern of faintly incised lines meeting at right angles.

No. 14 (fig. 40) from the entrance passage of the fort is a fragment of an outcurving rim, flattened on the top, and decorated internally by faint and rather irregular diagonal grooves. It is possibly a Neolithic stray.

No. 18 (fig. 40) from the entrance passage of the fort is a well-made rim of brick-red, sandy ware, rising from a constricted neck and curving slightly outwards.

Nos. 19 and 20 (fig. 40) and 21 (figs. 34 and 40), all from the fort, are rim fragments of ware similar to No. 18. The rims are straight and slightly flattened on the top, rising vertically from a constricted neck. The interior of No. 19 is marked with shallow horizontal grooves.

No. 22 (fig. 34) is a fragment of fairly thin but very coarse ware,

showing a hole pierced after firing. This is the only pierced fragment found.

No. 25 (fig. 33) is one of a number of fragments from the entrance passage of a vessel, probably globular in shape with some eversion of the rim, well made of fine, gritty paste, smoothed externally, and about  $\frac{1}{4}$  inch thick. The piece illustrated probably comes from just below the rim, and its decoration suggests a band of large triangles finely incised, the lines being crossed with short strokes.

No. 26 (figs. 35 and 40) from the interior of the fort is a large rim fragment of a globular vessel of similar paste to No. 25, well made, and smoothed externally. A continuous band of incised herring-bone-decoration stretches from the rim down to a very small applied band decorated with a fine zigzag pattern.

Nos. 27 to 30 (figs. 33 and 34) are examples, all from the fort, of "finger-tip" decoration. Nos. 27 and 29 show a band of festoons worked up from the body of the vessel with a flat, pointed slip of bone or wood. No. 28 shows a very thin, flat cordon decorated with finger-tip impressions pressed in at right angles. No. 30 shows a thick cordon impressed irregularly so as to produce a twisted effect.

The types of base represented are shown in fig. 40 by No. 3 from the bank across the forecourt, No. 10 from stratum A in the chamber, No. 11 found immediately south of P. 11, No. 12 found east of Q. 2, and Nos. 23 and 24 from the fort.

It may be noted that no fragments showed sharp shoulders.

#### DESCRIPTION OF CHARCOAL.

Specimens of charcoal were examined by Mr M. Y. Orr of the Royal Botanic Garden, Edinburgh. Those from the fort were of Scots pine. On the charcoal from the chamber Mr Orr reports as follows:—

"The condition of the charcoal from Clettraval is such that microscopic examination is impossible, and determination of its identity was based on macroscopic features alone. So far as it is possible to say in these circumstances the wood appears to be that of the birch throughout, which is in accordance with similar finds made elsewhere. The diagnostic features are the relatively small, frequently septate, pores and biseriate rays."

#### COMMENTS.

*Structure of the Tomb.*—In its method of construction the tomb is clearly a near relation of the Clyde type of chamber tomb, which is

sometimes, though I think unfortunately, called a "long cist." In what is generally regarded as its earliest form, best represented in Arran,<sup>1</sup>

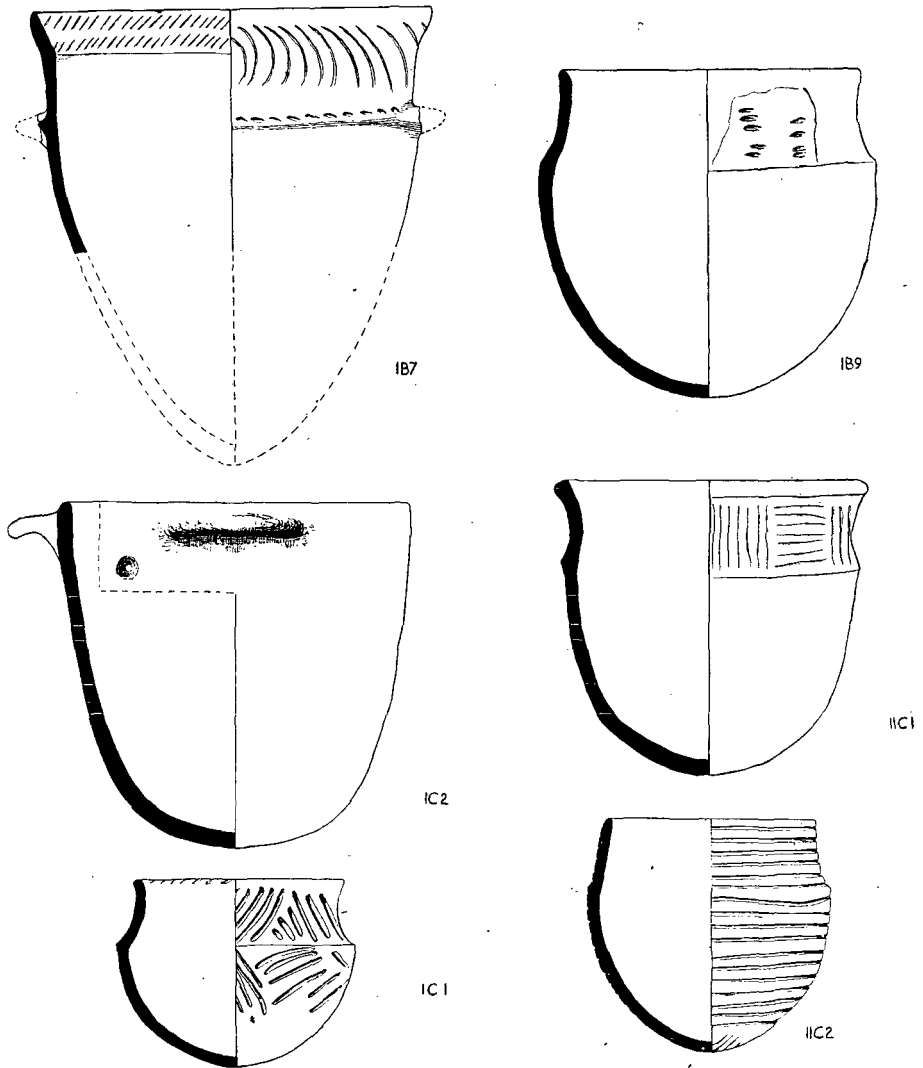

Fig. 38. Pottery from Chamber. (4.)

this is a long narrow chamber divided into sections by septal slabs, with orthostatic walls leaning inwards and supported either by overlapping

<sup>1</sup> T. H. Bryce, *Proc. Soc. Ant. Scot.*, vol. xxxvi. pp. 74 ff.; vol. xxxvii. pp. 36 ff.; and vol. xxxviii. pp. 17 ff.

their next neighbour or by the septa. It is roofed by a corbelled barrel vault, and opens directly on to a semicircular forecourt with an ortho-

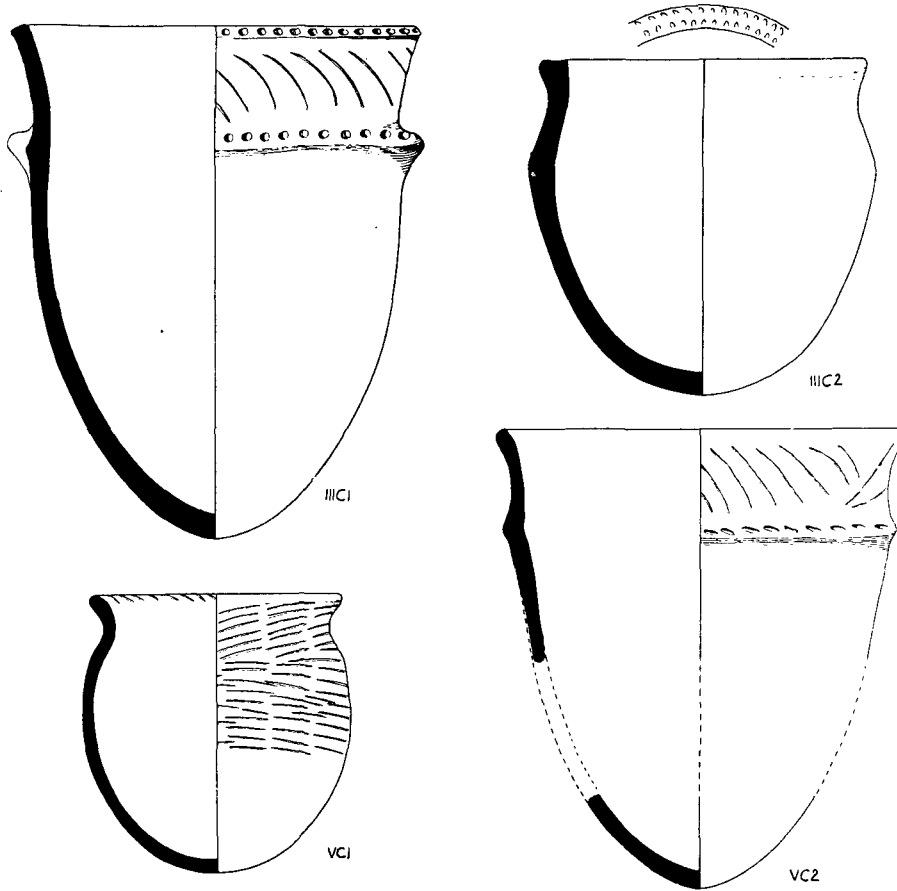

Fig. 39. Pottery from Chamber. (1.)

static façade. The peristalith is rectangular or wedge-shaped in plan, and the whole is covered by a long cairn.

The type is spread in Scotland from Galloway to Argyle and over the islands.<sup>1</sup> A degenerate example is found as far north-east as Kindrochat in Perthshire,<sup>2</sup> and in the Hebrides certain tombs were provisionally classified as belonging to the type by the Scottish Historical

<sup>1</sup> For a study of the distribution see C. Fox and W. F. Grimes, *Arch. Camb.*, June 1928, pp. 137 ff.; and V. G. Childe, *The Prehistory of Scotland*, pp. 25 ff.

<sup>2</sup> V. G. Childe, *Proc. Soc. Ant. Scot.*, vol. lxiv. pp. 264 ff.; and vol. lxxv. pp. 281 ff.

Monuments Commission.<sup>1</sup> Recent excavation has shown that it extended to Northern Ireland, where a tomb at Goward, Co. Down, provides a

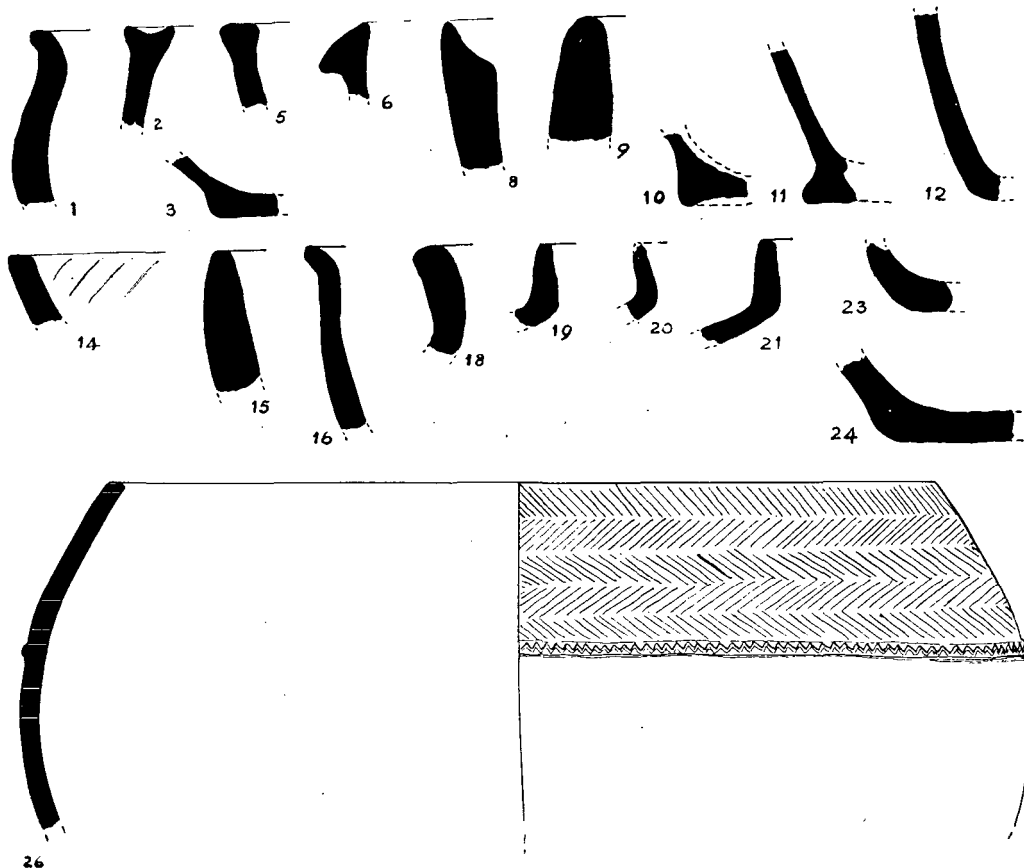

Fig. 40. Pottery from bank across Forecourt (1 to 6); from stratum A in Chamber (8 to 10); from south of P. 11 (11); from east of Q. 2 (12); from Fort (14 to 26). ( $\frac{1}{2}$ .)

good example of the type.<sup>2</sup> In England two of the five chambers in Minning Low, Derbyshire, appear generally similar.<sup>3</sup> Sir Cyril Fox and Mr Grimes in the paper quoted in note 1 on p. 523 suggest that Corston Beacon, Pembrokeshire, though a true long cist, *i.e.* a closed box, derives ultimately from this stream of the chamber tomb tradition, and further

<sup>1</sup> *Outer Hebrides, Skye, and Small Isles*, 1928, p. 29.

<sup>2</sup> O. Davies and E. E. Evans, *Belfast Nat. Hist. Soc.*, 1932-33, pp. 1 ff. For a valuable study of the distribution of the type in Northern Ireland, see E. E. Evans and Miss M. Gaffikin, *Irish Nat. Journ.*, vol. v., No. 10, July 1935.

<sup>3</sup> For plans see C. Fox and W. F. Grimes, *op. cit.*, *supra*.

quote, as possible examples of the type, tombs in Southern Ireland, Cornwall, and N.E. Spain. It was Professor Childe,<sup>1</sup> however, who first worked out the derivation of the type from chamber tombs in south-west France and Catalonia.

Clettraval agrees with the type as represented in Arran in its peristalith wedge-shaped in plan, its overlapping and inward leaning walls, its septal slabs and, probably, in its roofing. It disagrees in having section I. of its chamber, and to a lesser degree section II., much wider than the remaining sections, and in having a rectilinear façade set backward from the forecourt axis. The former difference connects it with the type of tomb structure composed of chamber, antechamber, and passage, which stretches from Caithness to Southern Iberia.

The rectilinear façade set back at more than a right angle from the forecourt axis does not seem to be precisely paralleled,<sup>2</sup> but is presumably to be connected with the flat façade which, though less studied than the crescentic one, is perhaps of not less importance as an early type. In England, Wayland's Smithy, Berkshire, had a flat façade,<sup>3</sup> and so had some Menorcan *navetas*.<sup>4</sup> It is interesting to note that the tomb of Midhowe, Orkney, which so closely resembles a *naveta*, had a flat end.<sup>5</sup> Rectangular forecourts exist in Almeria.<sup>6</sup> The type may ultimately derive from the tomb cut into a flat rock-face, vertical or sloping, such as occurs in Mallorca, Sicily, and the Ægean.<sup>7</sup>

The double curve in the axis of the chamber, if, as is probable, it is not the result of accident, is a rare feature. The *allée coucée* of Brittany normally makes a single bend, and that through a right-angle, though in Les Pierres Plates<sup>8</sup> the angle is smaller. The chamber of Gav'r Inis,<sup>8</sup> Southern Morbihan, makes a double bend, but it is a very slight one and may not be intentional. Moreover, these Breton tombs are widely different in type from Clettraval, and may quite possibly be later in date. It is of interest to note that in Puig Rodo, Catalonia, a tomb which is of the type believed by Professor Childe to be ancestral to the Clyde type, the outer of the three sections of the chamber appears from the

<sup>1</sup> V. G. Childe, *Glasgow Arch. Soc. Trans.*, November 1931, pp. 120 ff.

<sup>2</sup> As stated above, however, the façade of the neighbouring chamber tomb of Unival may turn out to be of this type.

<sup>3</sup> T. D. Kendrick and C. F. C. Hawkes, *Archæology in England, 1914 to 1931*, p. 63.

<sup>4</sup> W. J. Hemp, *Ant. Journ.*, vol. xii. pp. 127 ff.

<sup>5</sup> J. G. Callander and W. G. Grant, *Proc. Soc. Ant. Scot.*, vol. lxxviii. pp. 320 ff.; cf. W. J. Hemp, *Proc. Prehist. Soc.*, 1935, pp. 108 ff.

<sup>6</sup> L. Siret, *L'Espagne Préhistorique*, p. 40.

<sup>7</sup> Compare, for example, Tomb No. 7 in Mallorca, which also had a rectangular forecourt. W. J. Hemp, *Archæologia*, vol. lxxvi. pp. 121 ff.

<sup>8</sup> Plans in Péquart and le Rouzic, *Corpus des Signes Gravés des Monuments Mégalithiques de Morbihan*, 1927.

plan available to have been set at an angle to the axis of the inner sections.<sup>1</sup> There is, of course, nothing *prima facie* unreasonable in a curving passage, which is a common feature of domestic architecture in the higher latitudes.

Like Cletraval, the chamber tomb of Bryn Celli Ddu,<sup>2</sup> Anglesey, has a free-standing pillar, which was placed on the north side of the single chamber, just clear of the wall. Mr Hemp has shown that this did not quite reach the roof, and served no structural purpose. There is a pillar somewhat similarly placed in the main chamber of Le Déhus,<sup>3</sup> Guernsey, which reached the roof, and may have been placed to support a cracked cover stone. Lukis, however, found a deposit of human bones and pottery at the foot of the pillar, and had no doubt that this had been placed against and around its base after its erection; it is possible, therefore, that it served a ritual purpose, whether or not it also served a structural one. Pillars are a common feature of Iberian corbelled tombs;<sup>4</sup> their purpose is assumed to have been structural. The position of the Cletraval pillar makes it somewhat unlikely that it was structural, and it is probably to be compared with the ritual pillar of Bryn Celli Ddu.

The area partitioned off in section I.—if this is the correct interpretation of the facts—can be paralleled by the similar enclosures in the chamber of Marcella, Algarve.<sup>5</sup> At Unstan, Orkney, both end sections of the transversely set gallery were partitioned off, and one of these was subdivided into two by a slab.<sup>6</sup> At Midhowe, Orkney, the end section was divided transversely by slabs, and two skulls were found in the inner part; in the outer part a small area was partitioned off, but was empty.<sup>7</sup> In the outer section of the chamber of the second long cairn at Yarrows, Caithness, was a cist containing cord-decorated sherds and a necklace of disc-shaped lignite beads; from these finds it is doubtful whether it formed an original element in the tomb.<sup>8</sup> In the inmost and largest of the four sections of the chamber at Largie, Kilmartin,

<sup>1</sup> L. Pericot, *La Civilización Megalítica Catalana*, 1925, pl. i., No. 14 (not 13 as stated in the key to the plate).

<sup>2</sup> W. J. Hemp, *Archæologia*, vol. lxxx. pp. 179 ff.

<sup>3</sup> T. D. Kendrick, *Archæology of the Channel Islands*, vol. i. pp. 133, 134, 139, and 140.

<sup>4</sup> Cf. Los Millares, Tomb 17 and Almizarique in Almeria, a tomb at Gor in Granada and Cueva de Menga, Antiquera, the last of which is a slab-roofed tomb. Plans of these are in Obermaier, "El Dolmen de Matarubilla," *Com. de Invest. Paleont. y Prehist.*, No. 26 (1919).

<sup>5</sup> Drawing and plan in Åberg, *La Civilisation Énéolithique dans la Péninsule Ibérique*, p. 18, after Cartailiac.

<sup>6</sup> J. Anderson, *Scotland in Pagan Times*, vol. ii. pp. 292 and 293.

<sup>7</sup> J. G. Callander and W. G. Grant, *Proc. Soc. Ant. Scot.*, vol. lxxviii. pp. 320 ff.

<sup>8</sup> J. Anderson, *op. cit.*, vol. ii. pp. 239 and 240.

Argyllshire, which was a tomb of the Clyde type, Canon Greenwell found a cist in one corner empty of remains.<sup>1</sup>

The purpose of such partitioned-off areas in chambers remains obscure, and Clettraval only throws light to the extent that the two relatively complete pots in section I., stratum C, were found within the enclosure.<sup>2</sup> Built enclosures are recorded, though rarely, in both rock-cut and tholos tombs in the Ægean, where they are presumably variants of the common feature of a pit dug in the floor of the chamber. Dr Wace, in his recent invaluable study of the funerary practice disclosed by the Late Helladic tombs of Mycenæ, concludes that the majority of pits were designed for an individual burial, though many of them were used, and some may have been originally constructed, as charnel pits for holding the bones and offerings remaining from former burials.<sup>3</sup> The Clettraval enclosure may therefore be interpreted as designed for an individual burial.

The tripartite character of the peristalith at Clettraval may be compared with the arrangement at Pant y Saer, Anglesey.<sup>4</sup> There, though on a much smaller scale, was a peristalith composed of an inner dry wall of limestone, an intermediate packing of grit stone blocks and an outer ramp of tilted slabs. At Pant y Saer this ramp might be interpreted, though not very plausibly, as a structural device intended to support the limestone wall against the pressure of the mound. This mechanical explanation would not be valid at Clettraval, where the fall of the ground would have prevented the slab ramp from giving any support to the great wall of upright blocks which formed the inmost element of the peristalith.

The only Scottish example known to me of the slab ramp as an element in chamber-tomb architecture is the somewhat uncertain one of Kindrochat, Perthshire,<sup>5</sup> where it was not quite clearly differentiated from the surrounding wall. The element was first recognised by Mr W. J. Hemp in his excavations at Capel Garmon, Denbighshire,<sup>6</sup> and was again found by the same excavator at Belas Knap, Gloucestershire,<sup>7</sup> and at the great tomb in Plas Newydd Park, Anglesey.<sup>8</sup> In all these instances it was regarded as a structural device to support the surrounding dry stone wall of the mound. In the light of the Clettraval evidence this explanation becomes doubtful.

<sup>1</sup> J. Anderson, *op. cit.*, vol. ii. p. 272.

<sup>2</sup> There is no doubt that the well-built cist already mentioned in the chamber of the Unival tomb served for an individual burial.

<sup>3</sup> A. J. B. Wace, *Archæologia*, vol. lxxxii. pp. 136 and 137.

<sup>4</sup> W. L. Scott, *Arch. Camb.*, December 1933, pp. 185 ff.

<sup>5</sup> V. G. Childe, *Proc. Soc. Ant. Scot.*, vol. lxxv., fig. 1, sections.

<sup>6</sup> W. J. Hemp, *Arch. Camb.*, June 1927, p. 12.

<sup>7</sup> W. J. Hemp, *Trans. Bristol and Gloucestershire Arch. Soc.*, vol. li. (1929) p. 268.

<sup>8</sup> Information from Mr W. J. Hemp.



The paved path in front of the forecourt façade at Cletraval is similar to a feature which was discovered by M. le Rouzic at Kercado, South Morbihan, where a broad causeway of closely packed stones surrounded the cairn immediately outside an ashlar wall, and curved in with the wall to the entrance of the chamber.<sup>1</sup> As has been pointed out, the paving at Cletraval joined on to the middle element of the peristalith, which was composed of a low wall of slabs laid horizontally; whether or not that was its intention, this did in fact serve as a path round the tomb. I do not know of any parallel to the built and paved path which led across the forecourt up to the entrance to the chamber.

*Neolithic Pottery.*—The types of Neolithic vessels represented raise questions wider than can usefully be considered here. It will be noticed, however, that, together with types well known in the Windmill Hill culture of southern England, there occur vessels elaborately decorated in grooved or incised technique, often over the body as well as the neck of the pot. The motives are groups of parallel lines, straight or curvilinear, sometimes forming a continuous band of uniform pattern round the vessel, and sometimes arranged in successive panels in which the lines run in opposing directions.

This type of pottery is found also at another North Uist site, Eilean an Tighe, where apparently it was manufactured on a considerable scale.<sup>2</sup> This site is on a tiny island in the Geireann Mill Loch, which has been partly submerged when the water-level was raised by the building of the mill dam. Pottery, polished stone axes, and flints were thus washed out of the soil and scattered on the sandy beach of the island, where they were noticed and collected by the late Dr Erskine Beveridge. These sherds and some others collected by himself were published by Dr Callander, who had the distinction of first realising their Neolithic character and the connection of some of them with Orkney pottery of Unstan type.<sup>3</sup>

It is to be observed that the stratification at Cletraval shows that this, apparently developed, type of pottery is not later in North Uist than the simple Windmill Hill forms, which at the type site occur in the lower level and are classified by Mr Stuart Pigott as Neolithic

<sup>1</sup> C. D. Forde, *American Anthropologist*, vol. xxxii., No. 1, pp. 71 and 72. See also the section of the tomb given in fig. 9 of M. le Rouzic's paper in *L'Anthropologie*, vol. xliii. (1933) p. 237.

<sup>2</sup> This site is in course of excavation by the author.

<sup>3</sup> J. G. Callander, *Proc. Soc. Ant. Scot.*, vol. lxiii. pp. 29 ff.; and vol. lxxviii. p. 335, note 1. See also Professor V. G. Childe's recent comparison of Unstan and Eilean an Tighe pottery with that from a tomb at Slieve na Caillighe, Co. Meath, *Journ. Roy. Soc. of Ant. of Ireland*, vol. lxxv. pp. 320 ff., December 1935.

A. 1.<sup>1</sup> Thus I.B. 9 and I.C. 2, which are Neolithic A. 1 types, were stratified respectively above and with a characteristic Eilean an Tighe vessel, I.C. 1. Further evidence that the simple and the developed forms existed contemporaneously in the Hebrides is forthcoming from the Eilean an Tighe site.

Clettraval is linked by its pottery, as well as its structural form, to the Clyde type of tomb; for, of the four restored vessels from the Arran tombs, three closely resemble I.C. 2, while the fourth, from Clach-aig, has, in cord decoration, the rare pattern displayed by II.C. 1, a pattern which appears again at another tomb of the same form, Beacharra in Kintyre.<sup>2</sup> Thus the standard examples of the Clyde type of tomb, together with the Beacharra type of pottery, could, on the stratification evidence of Clettraval, be equated with the lowest stratum of Windmill Hill, a due time-allowance being made for the spread of the culture. So simple a type as I.C. 2 may, however, have had a long life.

It would be beyond the scope of this paper to pursue these pottery types back to their continental origins, but it has been noted above that Professor Childe has derived the Clyde type of tomb from the Pyrenean area, and the possibility may be remarked that the pottery derives from the same source. It is fairly certain that at any rate the Eilean an Tighe type of decoration cannot be derived from English Neolithic A, and Mrs Hawkes' analysis of the pottery from cave sites in the Departments of Gard and Aude suggests an origin for this in Southern France. There is some evidence from stratification that, in those Departments, this pottery succeeds plain, uncarinated vessels with lugs, is contemporary with plain carinated vessels and precedes beakers.<sup>3</sup>

Many of the patterns from the Gard and Aude caves can be paralleled across the Pyrenees in Catalonia, where, unhappily, stratification evidence is not available. It is therefore worth noting that the pottery types at Clettraval, both carinated and uncarinated, which are wholly or almost undecorated, are closely similar to undecorated vessels in caves in Southern Catalonia, notably Cueva Fonda de Salamó, where the patterns of the Gard and Aude caves are also found. It is even the case that the Clettraval beaker, I.B. 3, which looks at least odd by British standards, is markedly like in its multiple rows of dots and of

<sup>1</sup> Stuart Piggott, *Arch. Journal*, vol. lxxxviii. (1931) pp. 67 ff.

<sup>2</sup> The Continental connections of the Beacharra pottery generally, and of this pattern in particular, are studied by Professor V. G. Childe in *Arch. Journ.*, vol. lxxxviii. (1931) pp. 37 ff. The pattern appears in cord decoration in Northern Ireland among the Larne sherds in the Ashmolean Museum, Oxford (see *P.S.E.A.*, 1932, pp. 62 ff.). For the Arran pottery, see J. G. Callander, *Proc. Soc. Ant. Scot.*, vol. lxiii. pp. 29 ff.; for the Beacharra pottery, see Stuart Piggott, *op. cit.*, *supra*.

<sup>3</sup> Jacquetta Hawkes, *Antiquity*, March 1934, pp. 24 ff.

heavily incised lines to vessels of the Salamó type,<sup>1</sup> and that cardium decoration is common in that area. It is thus a possibility that Clettraval and tombs similar to it in type can be directly related, both as regards tomb form and as regards pottery types, with the Copper Age culture which spread across Catalonia and Southern France. If this were so it would follow, on the stratification evidence of the caves and of Clettraval, that the connection continued through a substantial period of time, during which beakers displaced the earlier pottery which in Britain is named "Neolithic."

*Burning of Bones.*—Attention should be drawn to the opinion of Miss Tildesley that the fragments of human bone recovered from the lowest stratum of section I. of the chamber must have been in immediate contact with a fire which consumed the parts of the body represented—before the flesh was decayed—as thoroughly as a cremation would have done. We know from Dr Wace's already quoted analysis of funerary practice at Mycenæ that tombs were fumigated with braziers or incense burners before a fresh burial was made in them, perhaps in order to drive out any lingering ghosts. In one of the Mycenæan tombs a fire had been lit, presumably to the same end, and this more radical method may be conjectured to be that belonging to a less sophisticated culture than the Late Helladic.<sup>2</sup> The practice is commonly now invoked, under the perhaps misleading name of purification by fire, to explain away the evidence of cremation in British chamber tombs, even where the burning was as thorough as it was in some of the long barrows of Yorkshire.<sup>3</sup>

It will be noticed that this practice will not explain the phenomena observed by Miss Tildesley except on the assumption that the tomb was re-opened and the fire lit so shortly after a former burial that a body remained undecayed in the chamber. There is nothing very unlikely in this assumption but, even if it were not a true one in the present case, I do not think that from the evidence of this mere handful of bones cremation should be inferred. Indeed, had even one complete cremation occurred among the many burials which took place in the chamber, more extensive remains might have been expected; for burnt bone is often preserved where unburnt is wholly decomposed.

Except in so far as precise and well-studied archæological data are

<sup>1</sup> Cf. Cueva Fonda de Salamó and Cueva del Cartanyá in Bosch-Gimpera, *Etnología de la Península Ibérica*, 1932, figs. 112 and 114, and discussion on p. 160. For Cueva Fonda, see also figs. 186 to 197 and 309 to 312 in Åberg, *La Civilisation Énéolithique dans la Péninsule Ibérique*, 1921.

<sup>2</sup> A. J. B. Wace, *op. cit.*, pp. 144 and 145.

<sup>3</sup> For example by Professor V. G. Childe, *Dawn of European Civilisation*, pp. 288 and 289. Cremation is, however, now attested in the Northern Ireland group of horned cairns of the Clyde type already mentioned.

available our only recourse is to modern funerary practice, and here such a variety of usages is found involving the application of fire that to rely on explanation in terms of one only, namely, purification by fire, is quite unsafe. Thus mutilation of corpses by fire, in order to incapacitate the ghost, can hardly be dismissed in the light of modern practice, when reliance is placed, in the case of Bronze Age burials, on mutilation by the breaking of limbs. Again, the passing of the returning burial party between or over fires to rid them of the accompanying ghost is attested as a recent usage and associated in intention with the practice of requiring them, for the same purpose, to creep through split tree trunks or holed stones.<sup>1</sup> Thus a fire within the tomb and a holed stone entrance might alike be means of ridding those who had deposited the body of the ghost that strove to return with them out of the tomb; while the twin fires at the entrances of Kercado in Morbihan<sup>2</sup> and Bryn Celli Ddu in Anglesey<sup>3</sup> might have served the same purpose. These are mere possibilities, but a recognition of the possibilities open in the light of modern cults of the dead is of great assistance to the practical excavator seeking to recover evidence of the cults of prehistoric times.

*Use of Stone Balls and Discs.*—The carefully shaped stone objects found in the pit in which Q. 2 stood show no sign of practical use. A stone ball has been found on the floor of the chamber of the Unival tomb mentioned above. Two stone discs were found at the chamber tomb of Pant y Sær, Anglesey, one against the inner side of the peristalith, and one in much disturbed material in the chamber.<sup>4</sup> A thick disc in the British Museum came from the chamber tomb of Keriaval, Morbihan, and a stone ball has recently been found immediately outside the peristalith of the larger Plas Newydd tomb in Anglesey.<sup>5</sup> The position of the majority of these specimens against the peristalith suggests that their purpose, like that of rounded, white quartz pebbles similarly placed, was a ritual one.<sup>6</sup>

*Iron Age Pottery and Date of the Fort.*—In Professor Childe's recent book, *The Prehistory of Scotland*, we have for the first time a complete analysis of the Late Bronze and Early Iron Age pottery of Scotland, and, in the light of this, a tentative classification may be tried of the

<sup>1</sup> For examples of these practices, see J. G. Frazer, *The Fear of the Dead*, vol. ii. pp. 29 and 30, 33 ff., 53 ff., 70 ff.

<sup>2</sup> C. D. Forde, *American Anthropologist*, vol. xxxii., No. 1, p. 72.

<sup>3</sup> W. J. Hemp, *Archæologia*, vol. lxxx. pp. 179 ff.

<sup>4</sup> W. L. Scott, *Arch. Camb.*, December 1933, p. 223.

<sup>5</sup> Information from Mr W. J. Hemp.

<sup>6</sup> It may be worth noting that precise analogues to the Clettraval and Unival specimens have been found in "votive" deposits near to, and associated with, the "Mycenean" corbelled tombs of Minet el Beida, North Syria. (F. A. Schaeffer, "Ras Shamra," in *Syria*, 1929, pp. 286 ff., and 1931, pp. 1 ff. and pl. xiii.)

pottery at Cletraval attributable to the users of the fort and of the secondary structures built in its ruins. It will be recollected that the sherds from the bank across the forecourt constituted a closed deposit which in all probability belonged to the period of the use, if not of the building, of the fort, whilst those from the fort itself might be either of that period or of that of the fort's decay.

An analysis of the pottery shows one marked distinction between the sherds from the fort itself and those from the bank and other parts of the site, namely, that decoration in the shape of a crinkled- or finger-printed band (as in Nos. 27-30) is very common among the former, but it is entirely lacking among the latter. This type of decoration is extremely common in Hebridean brochs and earthhouses, the use of which coincided, at least in part, with the Roman period; its absence from the bank is evidence that this, and therefore the fort itself, was built before the introduction of the style.

The origin of this type of decoration does not seem to have been discussed, but must presumably be sought in the finger-tip and finger-nail style introduced by the Urnfield and Hallstatt invaders of Britain.<sup>1</sup> On this view the crinkled band, formed with a pointed slip of bone, either on the pot itself (Nos. 27 and 29) or on an applied cordon (No. 30), would be a local Hebridean development of the band of finger-tip and finger-nail impressions seen in its simplest form in No. 28 and in a number of examples from brochs and wheelhouses. The crinkled band extends northward to one Caithness broch (Everley)<sup>2</sup> and southward to forts in Coll and Tiree,<sup>3</sup> but is not elsewhere found outside the Hebridean area. The finger-tip markings impressed at right angles on the body of the vessel or on an applied cordon occur, on two or three sherds, in the lowest level at Traprain,<sup>4</sup> and are common at Scarborough.<sup>5</sup> Finger-tip impressions occur in Phase II. at Jarlshof, but only on the top of the rims.<sup>6</sup> There is no need, however, to seek further for the source whence finger-tip decoration reached the Hebrides than the south-west of England, from which area, as Professor Childe has shown,<sup>7</sup> large elements in the broch culture derived.

Of the few other decorated sherds, No. 1 from the bank and Nos. 16 and 17 from the fort show a horizontal band of incised triangles together

<sup>1</sup> For a recent discussion of this pottery, see C. F. C. Hawkes, *Proc. Prehist. Soc.*, 1935, pp. 39 ff.

<sup>2</sup> J. G. Callander, *Proc. Soc. Ant. Scot.*, vol. lxxv. p. 348.

<sup>3</sup> Erskine Beveridge, *Coll and Tiree*, plates, Pottery from Duns, Nos. 1 and 8.

<sup>4</sup> A. O. Curle, *Proc. Soc. Ant. Scot.*, vol. lviii. p. 257.

<sup>5</sup> For Scarborough, see R. A. Smith, *Archæologia*, vol. lxxvii. pp. 179 ff.

<sup>6</sup> A. O. Curle, *Proc. Soc. Ant. Scot.*, vol. lxxviii. p. 288.

<sup>7</sup> V. G. Childe, *The Prehistory of Scotland*, pp. 237 ff.

with jabs and circular depressions. No. 4 seems to be of the same general type. All the motives can be paralleled from All Cannings Cross,<sup>1</sup> and a precise analogy to the band of triangles occurs in the lowest level at Jarlshof;<sup>2</sup> the forms of these sherds can be paralleled at both sites. The motive survives into broch pottery but in a debased form, the triangles becoming sketchy and obscured by hatching; indeed, the whole broch style has tended to the freehand, and away from the geometrical. No. 7 from the bank is too small to be distinctive, but is closely similar to a sherd from Scarborough.

Nos. 25 and 26, fine, thin vessels from the fort, are typical of the best broch ware. Fringed lines as in No. 25 occur at Dun an Iardhard, Skye,<sup>3</sup> and close zigzags occur at the earthhouse of Foshigarry, combined as in No. 26 with a decorated cordon.<sup>4</sup> The shape of No. 26 is abnormal in that there is no eversion of the rim, but some of the fine vessels, decorated in similar style, from forts in Coll and Tiree figured by Dr Beveridge seem to be of this shape, although no sections are given.

With the exception of No. 6, which is probably a Neolithic stray, the rim forms shown in the top line in fig. 40, *i.e.* from sites other than the fort itself, can all be paralleled at Covesea,<sup>5</sup> and in the first two periods at Jarlshof. The steep and slightly hollow internal bevel of No. 8 from the chamber and of another vessel, unillustrated, from the bank is a Bronze Age form which is represented at Covesea, at Glenshee,<sup>6</sup> and in the lowest level at Traprain,<sup>7</sup> but not at Jarlshof. The thickened and flattened rims of Nos. 2 and 5 from the bank are typical at Covesea, Jarlshof, Glenshee, and Old Keig.<sup>8</sup> In No. 2, and in two further fragments from the bank representing a similar rim, the upper surface is hollowed along its length, and the hollow is decorated with a line of pin-pricks. The hollowing is paralleled at Glenshee, but the very distinctive decoration appears, so far as I know, only at Jarlshof, where it is found in the second period associated with similarly hollowed rims decorated with finger-tip impressions.<sup>9</sup>

Of the rim forms from the fort itself only two call for comment. No. 14, with flattened rim, appears to belong to a shallow bowl, a type of vessel which does not appear to be found at any of the Scottish sites

<sup>1</sup> M. E. Cunnington, *All Cannings Cross*, plates.

<sup>2</sup> A. O. Curle, *Proc. Soc. Ant. Scot.*, vol. lxxviii. p. 228.

<sup>3</sup> F. T. Macleod, *Proc. Soc. Ant. Scot.*, vol. lxxix. p. 69.

<sup>4</sup> Erskine Beveridge and J. G. Callander, *Proc. Soc. Ant. Scot.*, vol. lxxv. pp. 344 and 345.

<sup>5</sup> Miss S. Benton, *Proc. Soc. Ant. Scot.*, vol. lxxv. p. 190.

<sup>6</sup> W. Thorneycroft, *Proc. Soc. Ant. Scot.*, vol. lxxvii. p. 197.

<sup>7</sup> A. O. Curle, *Proc. Soc. Ant. Scot.*, vol. lxxix. p. 157.

<sup>8</sup> V. G. Childe, *Proc. Soc. Ant. Scot.*, vol. lxxvii. p. 46.

<sup>9</sup> A. O. Curle, *Proc. Soc. Ant. Scot.*, vol. lxxviii. p. 288.

mentioned above, though Dr Beveridge mentions a shallow saucer, possibly from a dun, in Coll or Tiree;<sup>1</sup> it can, however, be paralleled at Scarborough. It may alternatively be a neolithic stray. The vertical rims, with slight flattening on the top represented by Nos. 19-21, are suggestive of continental Hallstatt shapes,<sup>2</sup> but as they differ only in being more vertical from examples from Foshigarry they can possibly be associated with the broch culture.

Thus the pottery from the bank can be related, both as regards form and decoration, to that produced by Late Bronze and Hallstatt sites in the north and north-east of Scotland, including Jarlshof in its first and second periods, and cannot be related satisfactorily to broch types. The pottery from the fort itself, while including a number of types found in the bank, includes also undoubted examples of the broch culture. Amongst the latter are numerous specimens of crinkled bands, which, it has been suggested, represent a Hebridean development of the finger-printed band, which reached the islands, with other elements in the broch culture, from south-west England.

It may reasonably be inferred then that the bank and the fort were built by people in a Late Bronze-Hallstatt culture, comparable with that revealed in the north-east at Covesea and in the north at Jarlshof in its first and second periods. If this is so, Cletraval forms an exception to the thesis put forward by Professor Childe that the stone ring fort of the west and north, even in its simpler forms, is part of the broch culture, and was superimposed with the rest of the culture by a conquering minority from the south on a pre-broch population with Jarlshof traditions.<sup>3</sup> Whether the broch pottery at Cletraval is to be attributed to later users of the fort itself or to those who built their cells in its ruins, we have, unfortunately, no means of determining.

*The Use of the Tomb.*—Direct evidence of burials in the shape of human bones was confined to section I. of the chamber, for the single bone fragment from section II. was not identifiable as human. On the evidence of pottery distribution (*vide* table on p. 496 above) the majority of the burials were in section I., but the other sections also contained a number of vessels, and two restorable pots were found in section II., two in section III., and one in section V. We have no right, of course, to assume that each vessel, or even each complete vessel, represents a burial, but the scarcity of pottery in most Scottish chamber tombs

<sup>1</sup> E. Beveridge, *Coll and Tiree*, p. 175.

<sup>2</sup> Cf. the Hallstatt forms from Holland, published by R. A. Smith in *Archæologia*, vol. lxxvii, pp. 179 ff.

<sup>3</sup> V. G. Childe, *The Prehistory of Scotland*, pp. 243 and 244.

suggests that the dead were not usually offered a number of pots, while very many burials must have been without grave goods of any imperishable sort. The richness of Clettraval in this respect suggests considerable prosperity in North Uist in Neolithic times.

It is of course possible to account for the pots found in the outer sections of the chamber without assuming original burials in those sections. Thus, referring again to Dr Wace's analysis of Late Helladic practice, pottery in the *dromos* of a Mycenæan tomb might be due to the removal from the chamber of an earlier burial, either ceremoniously or without ceremony, or to funerary rites performed outside the entrance to the chamber.<sup>1</sup> For the former of these practices we have evidence at Clettraval in sherds of the same vessel found in different sections of the chamber,<sup>2</sup> and the two restorable pots found shattered in the north-east and south-east corners of section III. might have been thrown there from sections I. or II. The nearly complete and unscattered fragments of a vessel found on the north side of section V. could only have been ceremoniously removed thither from an inner section; alternatively they might have been deposited like the *kylikes* thrown down outside the chamber door at Mycenæ.

These doubts cannot be resolved without far more evidence than we possess of funerary practice in British chamber tombs. It is clear that at Clettraval section I. of the chamber was the main burial-place; it is very probable that burials also took place in section II., and not much less probable that they took place in section III. There is no reason to believe that section IV. was so used, and section V., if used at all, seems to have been used at most twice. It is to be noted that the use of outer sections for burial cannot be attributed to the filling up of section I., since parts of the beaker I.B. 3 from stratum B of that section were found in stratum B of section III., and indeed the total depth of funerary deposit in section I. did not exceed 2 feet.

The inference that the use of the outer sections for burial was at any rate abnormal supports the evidence derived from structural form that Clettraval is to be regarded as a chamber with either one or two antechambers and a passage rather than as a single chamber divided into five segments. If the latter is a correct description of the Clyde type of tomb—if, that is to say, each of the segments in that type was of equivalent use—Clettraval differs in the most important respect,

<sup>1</sup> A. J. B. Wace, *loc. cit.*, pp. 144 and 145.

<sup>2</sup> Fragments of one of the two Neolithic vessels found in Rudh' an Dunain chamber tomb, Skye, had been removed from the chamber into the antechamber (*Proc. Soc. Ant. Scot.*, vol. lxvi. p. 199), and at the Unival tomb already mentioned fragments of vessels from the chamber were found in the passage.



namely, in the funerary cult it represents. It is hardly certain, however, that all the segments of the tombs of Clyde type were of equivalent use.

From the quantity of pottery found, and from its stratification and development in type, it will probably be agreed that Cleittraval was used for numerous burials spread over a long period. The tombs of the Messará in Crete continued individually in use for several centuries in the third millennium;<sup>1</sup> parallel evidence is available for the second millennium at Knossos.<sup>2</sup> Several centuries can similarly be allowed for the development in pottery types at Cleittraval. If a pottery sequence is to be postulated from an uncarinated and undecorated vessel like I.C. 2, through carinated and decorated vessels like I.C. 1, to beakers like I.B. 3, considerable time must be allowed, whether the types be supposed to have reached the Hebrides from England or directly from Iberia or Southern France. For both in England and in Southern France there is stratigraphical evidence of the succession of the three types in time, and, whatever time-gap be allowed for their passage to North Uist, the types cannot have started on their several journeys after they had passed out of use in the country of their immediate origin. It is reasonable to conclude that in the succession of funerary deposits at Cleittraval we have a development in pottery types similar, and occupying a similar time, to that revealed in Southern England by Windmill Hill and in the Pyrenean area by the caves of Gard, Aude, and Southern Catalonia. From which of these two areas North Uist directly drew its culture there is no sufficient evidence to show, but the balance of probability seems to incline to the latter.

I should like in conclusion to express my indebtedness to Miss M. L. Tildesley for her report on the human bones, to Dr J. Wilfrid Jackson for examining the animal bones, to the late Dr H. H. Thomas for much assistance in matters of geology, to Mr M. Y. Orr for his report on the charcoal, and finally, to Mr Stuart Piggott for his many and admirable drawings of the pottery.

<sup>1</sup> For example, "Tholos" No. II. at Porti was in use from E.M. 1 to M.M. 1, a period which, on Sir Arthur Evans' chronology, would have amounted to as much as eight centuries (Xanthudides, *The Vaulted Tombs of the Messará*, pp. 57 and 61). The length of the E.M. period, depending as it does on rather insecure parallels with Egypt, may be over-estimated, but Dr Åberg's thesis that the Messará tombs, and the E.M. culture as a whole, are contemporary with M.M. 11 at Knossos is disproved by the evidence urged in its support. It is untenable that these tombs with their E.M. grave goods were those of the people using M.M. pottery and living in hamlets a few yards away from them. The same argument would prove that the Hebridean Neolithic and Iron Age cultures were contemporary because both were found side by side in the tomb and fort of Cleittraval (*cf.* N. Åberg, *Bronzezeitliche und Früheisenzeitliche Chronologie*, part iv. pp. 249 ff.).

<sup>2</sup> Tomb XVII. in the Mavro Spelio cemetery was in continuous use for six hundred years from M.M. 11b to L.M. 111b (E. J. Forsdyke, *B.S.A.*, vol. xxviii. p. 246).

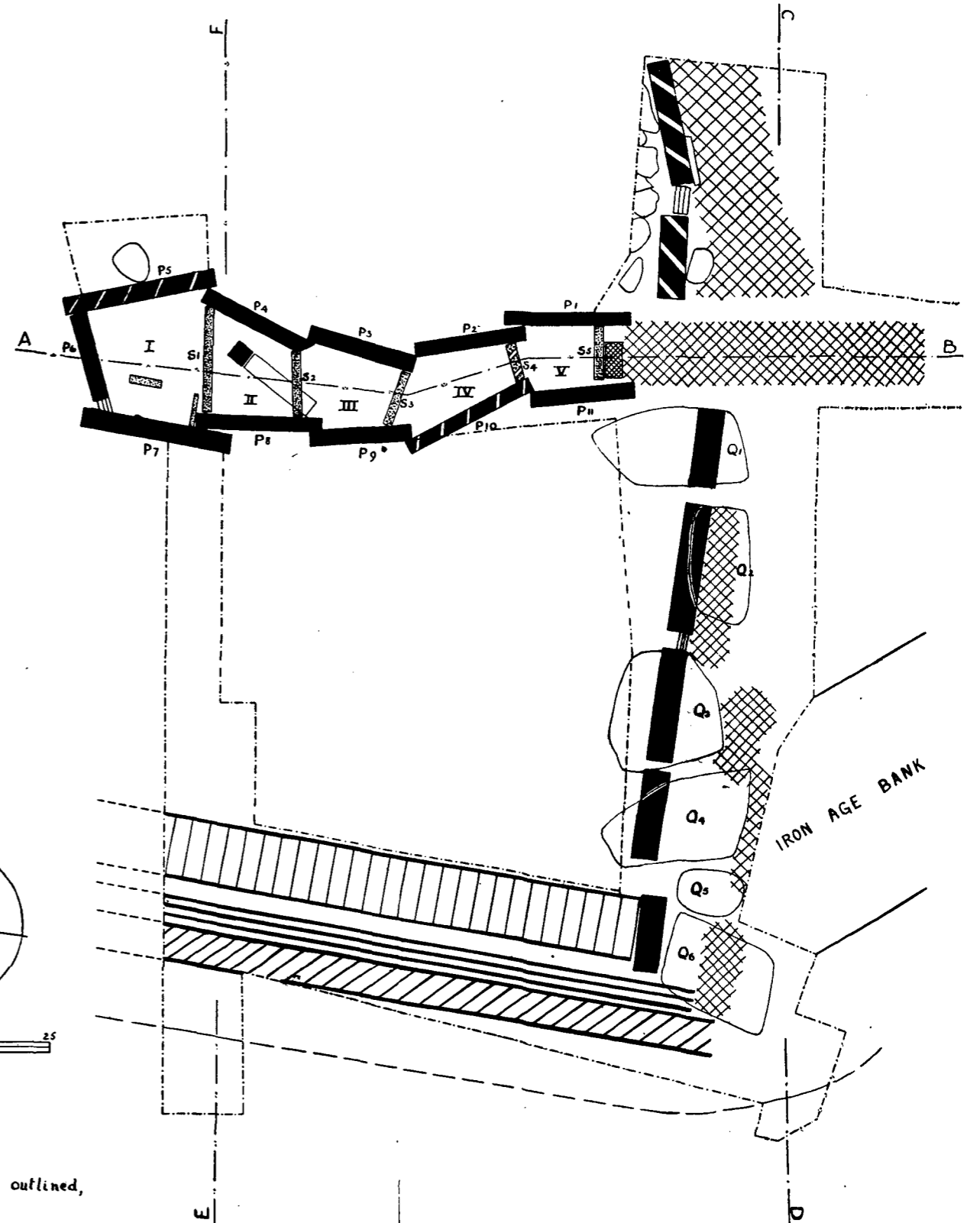
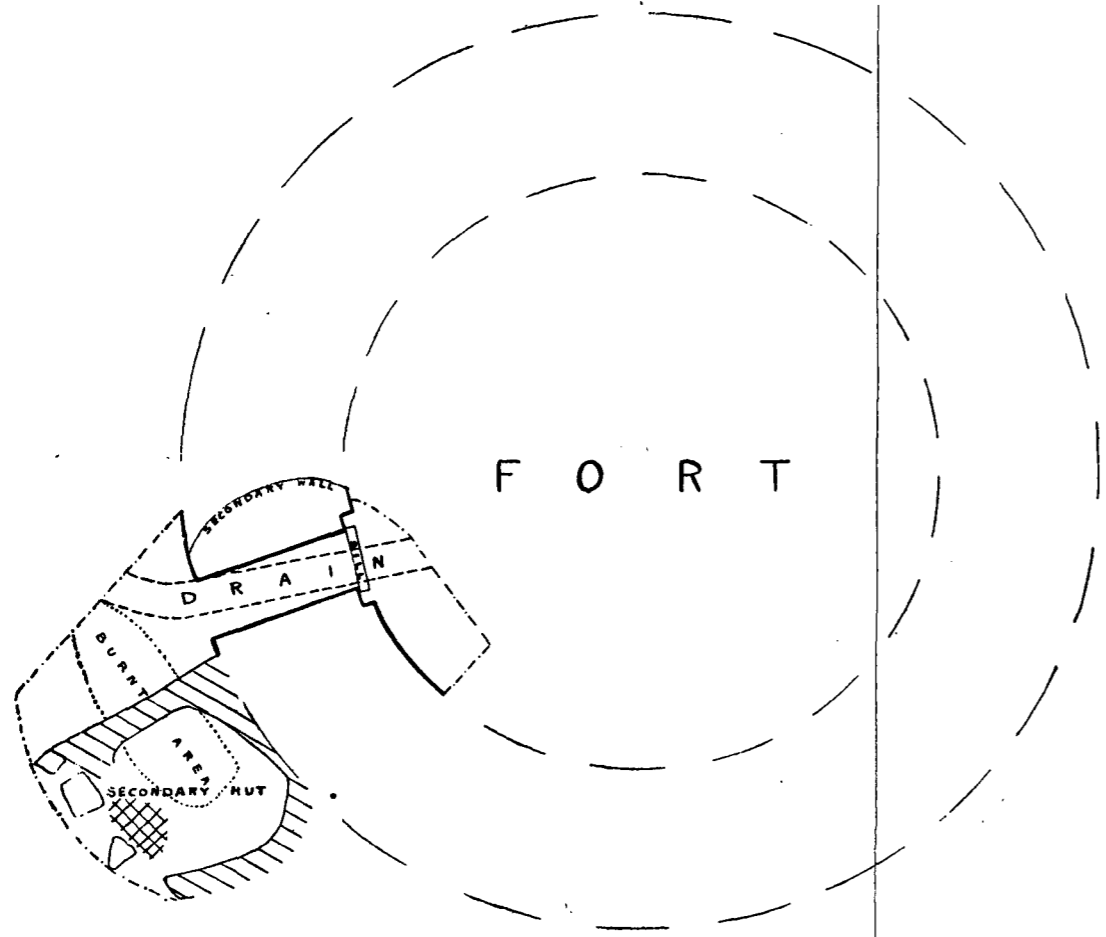

- SYMBOLS**
- Orthostatic slab or pillar
  - Presumed orthostatic slab
  - Septal slab
  - Presumed septal slab
  - Wall of orthostatic blocks
  - Wall of slabs laid horizontally
  - Ramp of filled slabs
  - Paved area
  - Doorstep
  - Periphery of cairn
  - Presumed periphery of cairn
  - Limits of excavations
  - Lines of sections

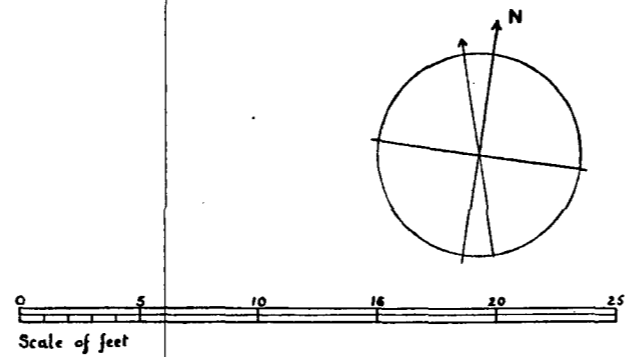

The present positions of the slabs of the forecourt facade and of the pillar in Chamber II are outlined, as are the abutments of the north facade and of P5.

Plan of Cleittraval Chamber Tomb and Fort.

W. LINDSAY SCOTT.

PLATE I.

[To face page 536.

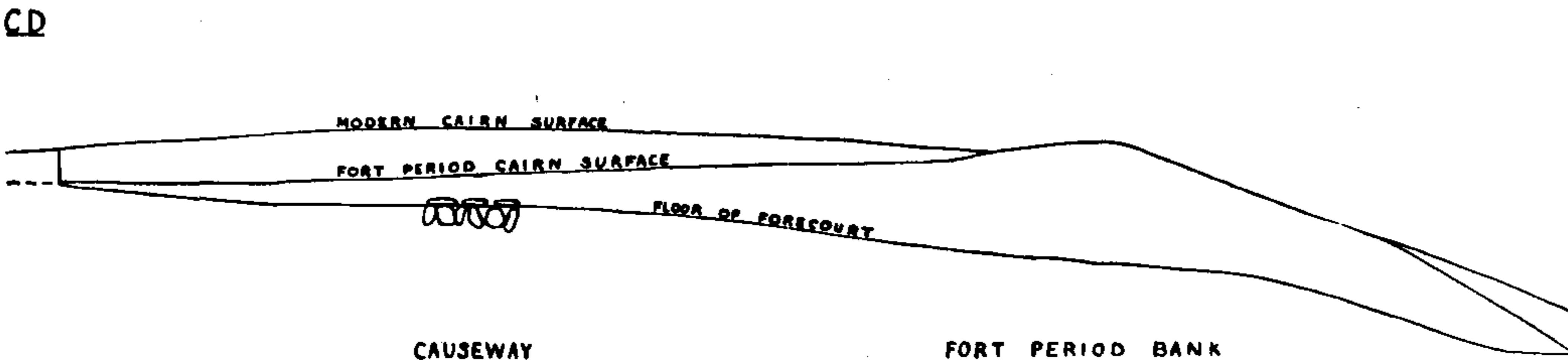
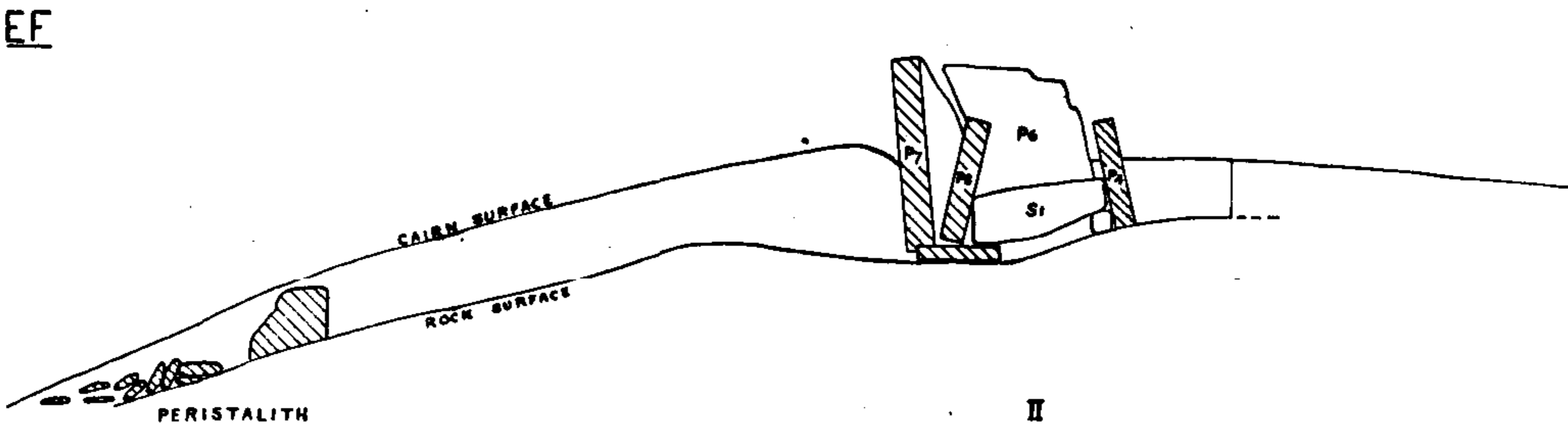
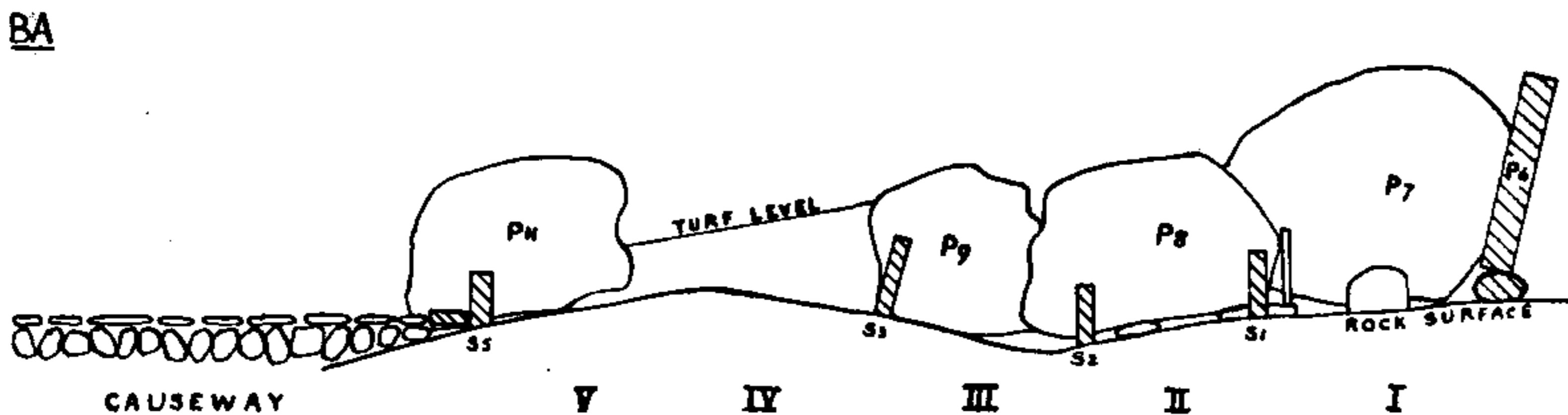
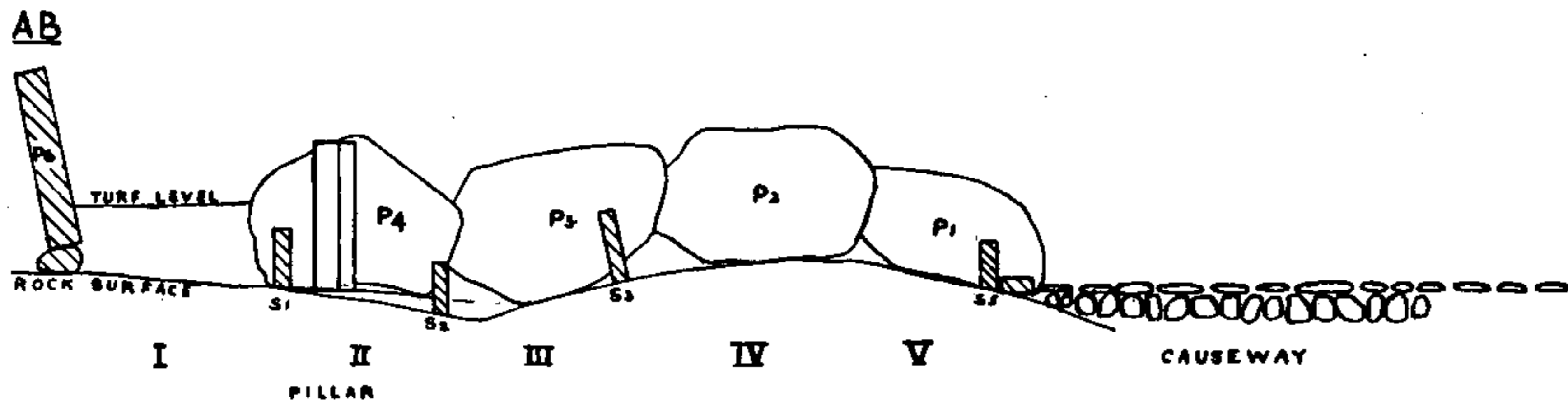

### ELEVATION OF FACADE

THE BASES OF PITS OF ORTHOSTATS ARE INDICATED WHERE ASCERTAINED. THE COMPLETION OF Q2 IS CONJECTURAL.

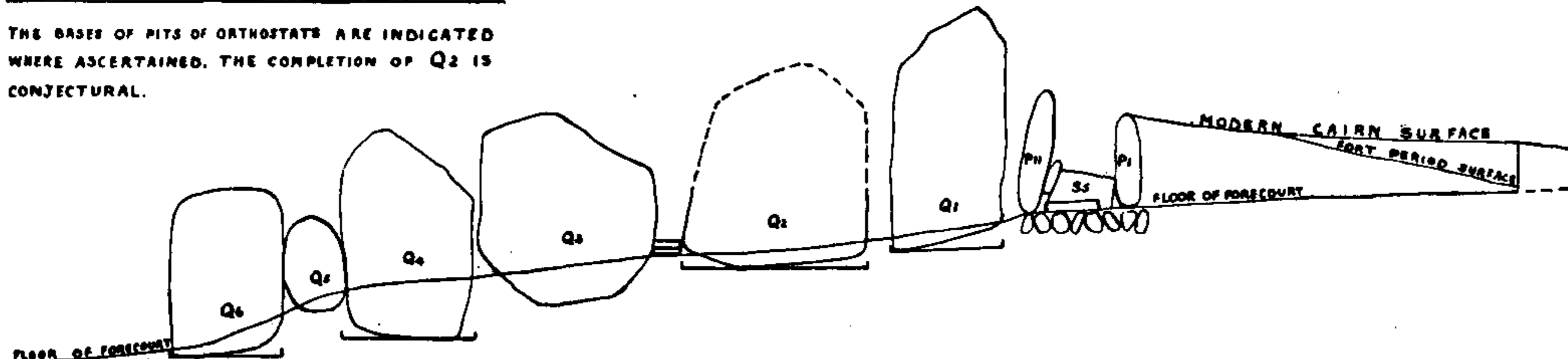

W. LINDSAY SCOTT.

Sections and Facade Elevation of Cletraval Chamber Tomb.

PLATE II.

[To face page 536.