

III.

VARIATIONS OF THE DOG LOCK FOUND ON SCOTTISH FIRE-
ARMS OF THE SEVENTEENTH CENTURY. BY CHARLES E.
WHITELAW, F.I.A.RCHTS.SCOT., F.S.A.SCOT.

During the last few years I have had the opportunity of examining some rare examples of Scottish firearms of the latter half of the seventeenth century, belonging to a type that I have not been able to deal with sufficiently in my past writings on this subject. I refer to those weapons fitted with what is known as the Dog Lock. Before going into details, I would draw attention to the subjoined list showing the types of lock fitted to Scottish firearms from the sixteenth to the early nineteenth centuries, to show the relative position of the Dog Lock, the limitations of period being based on dated examples.

The Early Snaphance Lock	.	Sixteenth century to about 1686		
The Late	„	„	.	From about 1647 „ 1702
The Dog Lock	.	.	.	„ 1665 „ 1700
The Flint Lock	.	.	.	„ 1700 „ 1820

The Dog Lock is the early form of Flint Lock. According to dated specimens, it was introduced into Scotland about the year 1665,¹ and was displaced by the fully developed Flint Lock about the year 1700.

Its immediate predecessor was the Late Snaphance Lock (fig. 1). This lock consists of the lock-plate (L), to which is attached, externally, the pan (P), with a fence (F); over the pan is a sliding pan-cover (PC), and above this the steel (ST). The cock (C) holds the flint between two jaws, which are closed by a pin² screwed through the lower jaw. The spindle (SP) is forged on the cock, the tumbler (T) slips on to the spindle and is secured by a nut or driving-pin, but there is no bridle to steady the spindle and reduce friction. When at full cock (there is no half cock) the cock is held by the breast of the sear (S), working horizontally, which springs over a flange (FL) on the tumbler (T). On pressing the trigger (TR) the sear is withdrawn from contact with the tumbler, and the cock falls, striking the flint violently against the steel, thereby generating the spark that ignites the powder

¹ An English example dated 1647 is illustrated in *European Hand Firearms of the 15th, 16th, and 17th Centuries*, by H. J. Jackson and C. E. Whitelaw (fig. 49).

² "Pin" is the term applied by a gunmaker to a screw that is screwed into metal and therefore does not require a point; he only calls it a "screw" when it is screwed into wood and therefore has a point.

in the pan. In falling, the cock pushes back the pan-cover by means of a small rod (R) inside the lock and connected with the tumbler (T), and at the same time the stroke of the flint throws up the steel, thus exposing the priming to the sparks. Other parts of the lock are the steel spring (STS), the pan-cover spring (PS), the pan-cover swivel (PSV), the main-spring (MS), the sear-spring (SS), the sear-lug (SL), and the comb of cock (CB).

Snaphance Locks have the important defect of having no provision for placing the lock at half cock, nor any other device whereby the weapons to which they are fitted may be carried with safety, when loaded and primed and ready for immediate use. This defect is accentuated by the fact that these early firearms, almost without exception, have no trigger-guard. The only way to avoid a premature discharge was to turn back the steel so that, should the trigger be pressed accidentally, the flint could not come into contact with it. The pan, however, would be uncovered by the fall of the cock and probably require repriming.

The Dog Lock shows a considerable advance on the system which it superseded, by the introduction of two important improvements. The first is the provision of a contrivance for putting the lock at half cock, but as this did not lock the mechanism securely, there was added a small outside safety-catch acting directly on the cock. It is this outside safety-catch which is the distinguishing feature of the Dog Lock. The second is the combination of the pan-cover and the steel to form one piece.

In Scottish firearms there are three distinct types of the Dog Lock, which will be described in their chronological sequence as Types I., II., and III.

Type I.—This is the earliest type (fig. 2). It has the cock similar in form to that of the late snaphance (fig. 1). Behind the cock is a long safety-catch (SC) swung on a pin and formed with a hook-shaped extremity to grip a notch in the rear of the cock above the level of the spindle. The pan has a fence of circular form, similar to that of the late snaphance but less in diameter. The pan-cover and the steel are combined in one piece by forging the pan-cover on to the lower extremity of the steel. The spindle and the cock are forged in one piece, the tumbler being slipped on to the spindle and secured by a nut or driving-pin. The tumbler is formed with a spur on the top, in front of which the nose of the sear working horizontally, catches when the cock is drawn back to half cock. The cock is then drawn back slightly and the safety-catch clipped into place by hand. When the cock is drawn back to full cock a flange

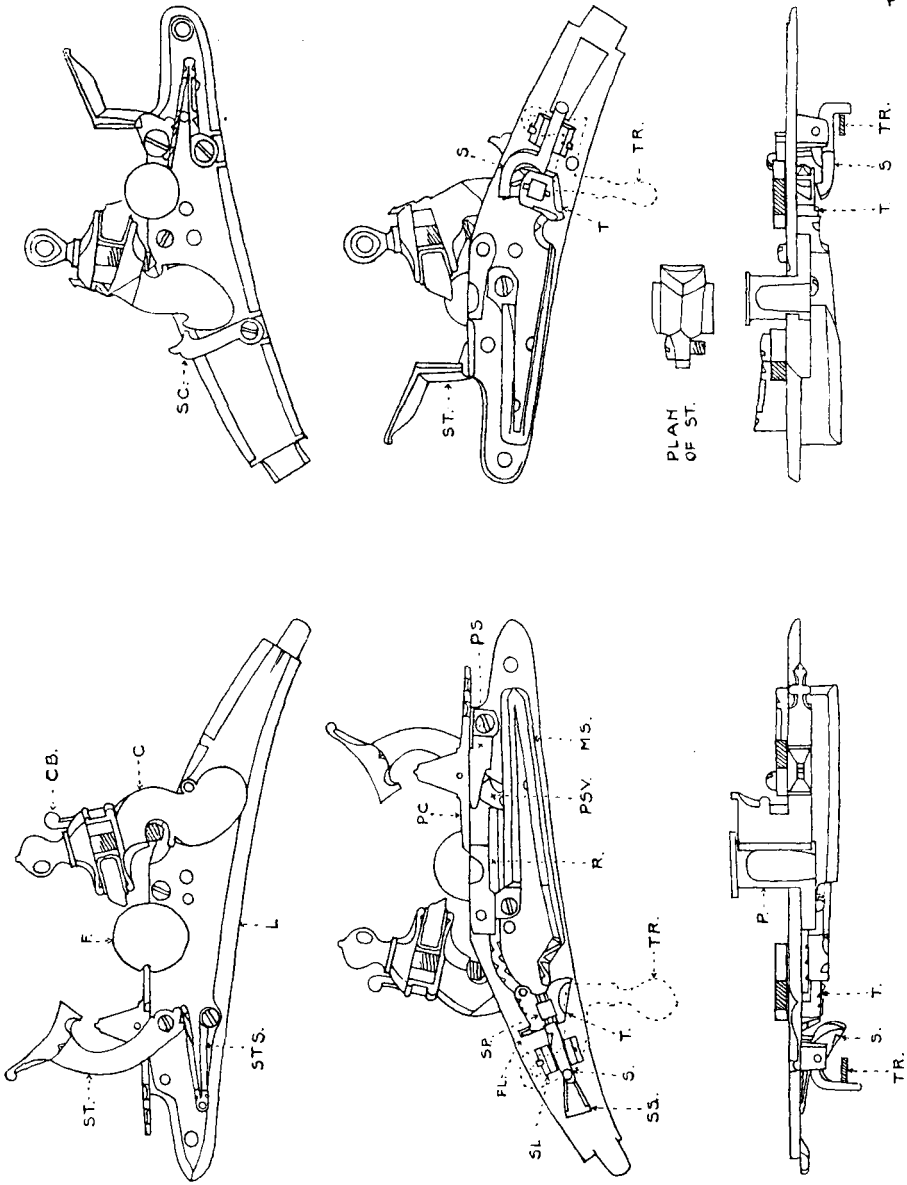

FIG. 2. DIAGRAM OF A DOG-LOCK, TYPE I. (HALF FULL SIZE) ABOUT 1665 SHOWN AFTER DISCHARGE, WITH THE PRESSURE ON THE TRIGGER.

FIG. 1. DIAGRAM OF A LATE SNAPHANCE LOCK. (HALF FULL SIZE) DATED 1647 SHOWN AFTER DISCHARGE, WITH THE PRESSURE ON THE TRIGGER.

towards the rear of the sear slips over a flange on the tumbler to the rear of the spur; at the same time the back of the cock throws the safety-catch out of gear. Pressure on the trigger disengages the sear from contact with the tumbler, and allows the head of the cock to fall forward and bring the flint forcibly into contact with the steel, which is thereby thrown up, exposing the priming to the sparks.

The earliest example on this system so far known is dated 1665, and is in the collection of Mr N. R. Colville, F.S.A.Scot. It is similar to fig. 2,¹ in the same collection, and is fitted to a pistol with a steel stock and a heart-shaped butt.² A small pistol of this type is illustrated in fig. 5.

Type II.—In this type (fig. 3) the exterior differs from that of Type I., in that the circular fence to the pan is done away with, and the safety-catch is smaller and different in form, and clips into a notch in the lower edge of the cock, below the level of the spindle. The interior mechanism differs from Type I., in having the sear extended to project through a square aperture near the top of the lock-plate and grip the breast of the cock, instead of a spur on the tumbler, at half cock. The cock is then lowered slightly and the safety-catch slipped into place by hand. When the cock is drawn back to full cock, the flange towards the rear of the sear slips over the flange on the tumbler, and at the same time the back of the cock throws the safety-catch out of gear. Pressure on the trigger disconnects the sear from contact with the tumbler, and withdraws the nose of the sear to within the lock. There is only one specimen of this type in existence so far as I can learn. It is signed *Thomas caddell* 1678, and is fitted to a pistol of rather rude workmanship with a steel stock and scroll butt. It is preserved in the Museum at Neuchâtel, Switzerland.

It will be noticed that the nose of the sear is set at right angles to form the stop for the cock which, being rectangular in section, does not allow the nose of the sear to get a grip of it, and hence the necessity for the safety-catch. There is a rather curious defect in the design of this lock. In Types I. and III. the lock is first put at half cock, then the cock is *drawn back* slightly and the safety-catch inserted; but in this example the nose of the sear has to be withdrawn by pressure on the trigger, and the cock *let forward* slightly before the safety-catch can be inserted—a very inconvenient and unpractical arrangement.

A question arises in connection with this example, Are all the parts contemporary? On examining it for the first time, I was inclined to

¹ The main-spring in this illustration is a late restoration.

² Figured in Drummond's *Ancient Scottish Weapons*, Plate xxviii., fig. 4. The safety-catch is missing. The pistol is remarkable in having the barrel rifled with eight grooves.

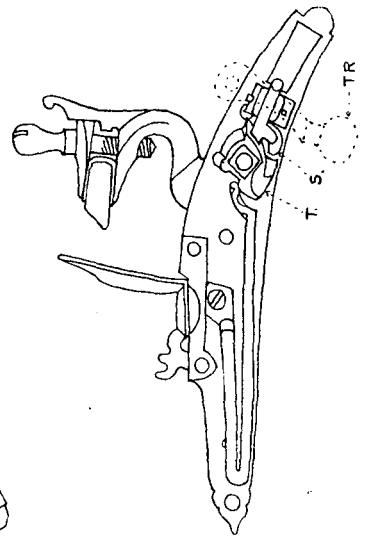
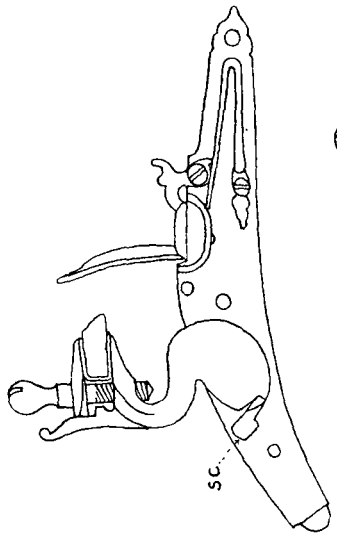

TUMBLER & SEAR
OF A FLINT LOCK
(AT HALF COCK)

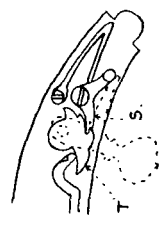

*cent.
026.*

FIG. 4. DIAGRAM OF A DOG-LOCK, TYPE III.
(HALF FULL SIZE). ABOUT 1090
SHOWN WITH THE SAFETY CATCH IN
GEAR.

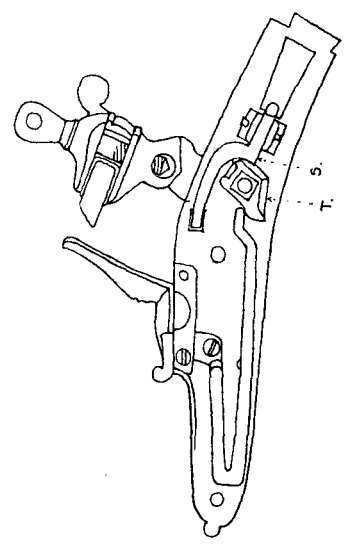
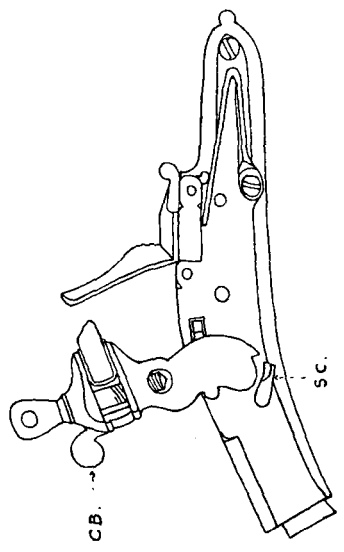

FIG. 3. DIAGRAM OF A DOG-LOCK, TYPE II.
(HALF FULL SIZE) DATED 1078
SHOWN AT HALF COCK

CB. →

think it possible that originally the sear had been similar in form to that of fig. 1, and that therefore the lock had no provision for half cock and had to rely on the safety-catch alone; that at a shortly later date a new sear with an elongated nose had been substituted and the lock plate perforated to allow of its projection to stop the cock. I am not disposed to maintain that opinion now.

This is a particularly interesting if not unique lock, whether all its parts be contemporary, or some of them altered as suggested, and it illustrates the work of the first Thomas Caddell, who is reputed to have originated the pistol-making industry in Doune.

The system illustrated in the internal mechanism of Type II. was continued in the immediately succeeding Flint Lock, as fitted to pistols with the scroll and lobe butts, down till the close of the eighteenth century. It is also found in a number of the pistols with the heart-shaped butt and a gun¹ made during the early years of the eighteenth century. In these later forms the breast of the cock is either rounded or bevelled, and the nose of the sear set at a slightly acute angle, thus forming a sort of dovetail which gets a sufficient grip on the cock to hold it firmly at half cock, and thus obviate the necessity for a safety-catch. Attention may also be drawn to the small circular terminal to the comb of the cock of fig. 3, which later on developed into the large perforated disc, a characteristic feature of so many of the finest pistols of the eighteenth century, with the scroll butt.

Type III.—This, the latest type (fig. 4), is externally the same as the succeeding Flint Lock, except that it has a small safety-catch identical in form and application to that of Type II. (fig. 3), and the cock and the spindle are still forged in one piece.² Internally the nose of the sear is prolonged downwards, and when put at half cock, working horizontally, butts on the rear of a spur on the lower edge of the tumbler. When the cock is drawn back to full cock, a flange on the upper part of the sear snaps over a flange on the upper edge of the tumbler, as in Type II. (fig. 3); at the same time the back of the cock throws the safety-catch out of gear. The spur on the tumbler and the nose of the sear, however, are not formed in a manner that secures the firm locking of the mechanism at half cock, as in the perfected Flint Lock (see detail on fig. 4), and therefore it is necessary to retain the safety-catch. There is an example of this type in the Museum, Perth; it is of steel with a scroll butt, and is signed DANIEL STEVART 1690. Another

¹ Preserved in Castle Grant, Speyside.

² In the Flint Lock the attachment of the cock and the tumbler is reversed from that of the Dog Lock, the spindle and the tumbler being forged in one piece and the cock slipped on to the spindle and held by a pin.

example of exceptional interest is illustrated in fig. 6, and described in detail.

Scottish specimens of the Dog Lock are scarce, and all the examples referred to are on pistols. No Scottish guns fitted with this type of lock have as yet come under my notice, and I would therefore be deeply obliged to anyone who would inform me of any further examples of firearms of this type.

TABLE OF EXAMPLES EXAMINED OR CLASSIFIED BY PHOTOGRAPHS.

Type I.

1. Pistol of steel with heart-shaped butt and rifled barrel, dated 1665. Length 11 inches. N. R. Colville, F.S.A.Scot.
2. Pistol of steel with heart-shaped butt, dated 16(-)3 on the barrel, which is a little later than the pistol. About 1665. Length $15\frac{5}{16}$ inches. N. R. Colville, F.S.A.Scot.
3. Pistol of steel with heart-shaped butt (fig. 5). About 1665. Length 10 inches. C. E. Whitelaw, F.S.A.Scot.
4. Pistol of steel with scroll butt. Signed A.W. 1670. Royal Armoury, Stockholm. (Classified from a photograph.)
5. Pistol with walnut stock and steel extension bar. About 1675. Net length $19\frac{3}{8}$ inches. N. R. Colville, F.S.A.Scot.

Type II.

- Pistol of steel with scroll butt. Signed *Thomas caddell* 1678 (fig. 3). Length $15\frac{1}{4}$ inches. The Museum, Neuchâtel, Switzerland.

Type III.

1. Pistol of steel with scroll butt. Signed DANIEL STEVART 1690. Length 16 inches. Museum, Perth.
2. Pair of pistols of steel with heart-shaped butts and right- and left-hand locks. Signed IO. STVART. About 1690. Length 19 inches. The Duke of Argyll.
3. Another pair, similar, by the same maker. About 1690. Royal Armoury, Stockholm.
4. Pistol of steel with heart-shaped butt, unsigned (fig. 4). About 1690. Length $14\frac{5}{8}$ inches. N. R. Colville, F.S.A.Scot.
5. Pistol with rosewood stock and heart-shaped butt. Signed IO. STVART (figs. 6 and 7). About 1695. Length 11 inches. C. E. Whitelaw, F.S.A.Scot.

Of the types of pistols referred to, I exhibit two specimens which are in my own collection. These are illustrated in figs. 5, 6, and 7.

The first is a pistol of steel with early Dog Lock of Type I. and heart-shaped butt (fig. 5). The barrel is octagonal at the breech and muzzle, and inlaid with cross bands of silver. The cock is engraved with floral scrolls, and there are traces of engraving on the silver bands. This pistol is remarkable in not having been fitted with a picker. The pin closing the jaws of the cock is about twenty years later than the pistol, and the weapon has suffered severely from ruthless over-

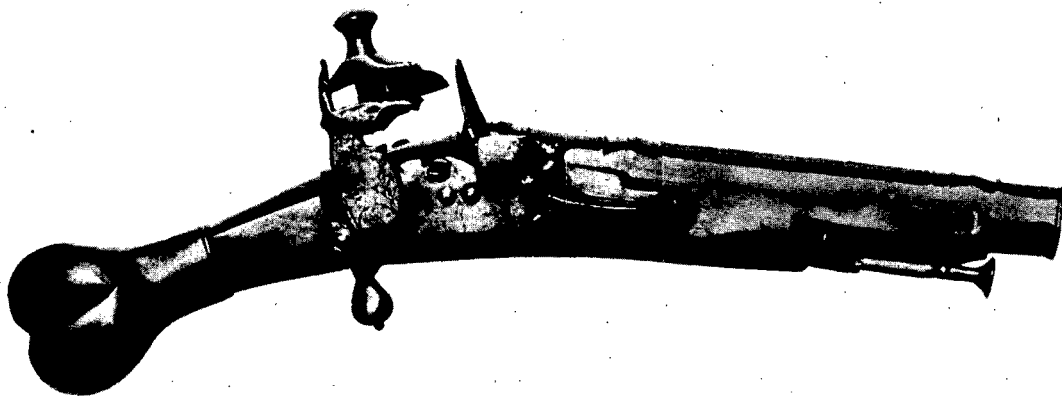

Fig. 5. Pistol with Dog Lock (Type I.).

cleaning. It is 10 inches in length, with a bore of $\frac{9}{16}$ inch. It was made about 1665.

The second is a pistol with rosewood stock, late Dog Lock of Type III., and heart-shaped butt (figs. 6 and 7). The lock is finely engraved with leaf scrolls, etc., and signed IO. STVART. There is a mask chiselled on the cock after the fashion of continental firearms. The stock is finely modelled and finished, and the mounts are of silver boldly engraved with floral scrolls. The mounts consist of a band starting at the strap of the breech block, extending the length of the butt, and continuing down the extremity of the pommel and along beyond the trigger; it has a narrow nose-cap, and nose- and tail-pipes for the ram-rod, which is missing. The ram-rod pipes are delicately moulded, and the ball terminals of the trigger and picker¹ are chased with bands of fluting. The

¹ The picker is a dummy.

back plate is pierced and engraved, and there is the usual steel belt-hook. The barrel is circular, except close to the breech, where it is octagonal. It is ornamented with narrow moulded cross bands enclos-

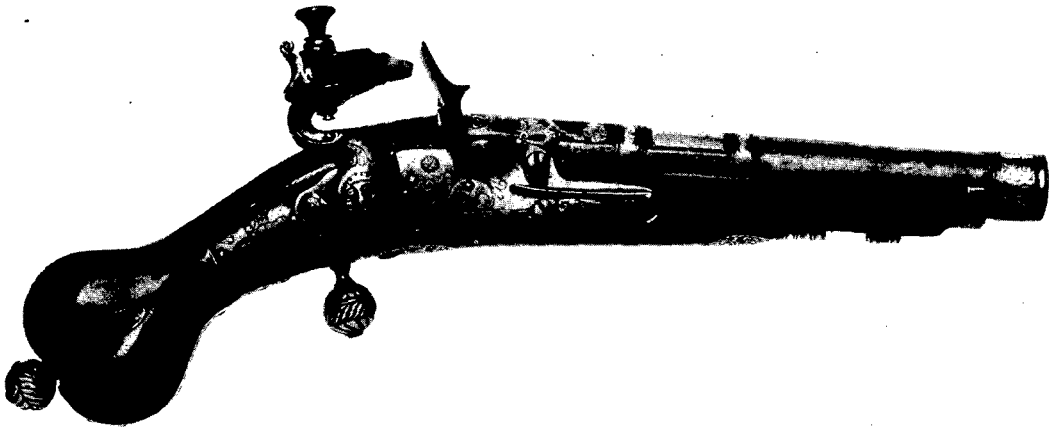

Fig. 6. Pistol with Dog Lock (Type III).



Fig. 7. Top View of Pistol with Dog Lock (Type III).

ing inlaid bands of silver, a rectangular escutcheon (blank), and a panel of floral design, all engraved with floral scrolls, except on the two narrow bands, where a sort of water-leaf or dentil is used. On the band round the muzzle appears the head of a man with a pointed beard and a brushed-up moustache. This pistol is believed to be

unique, and is certainly of rare quality of design and workmanship, and in a state of preservation rarely found in Scottish weapons. Its length (excluding picker) is 11 inches and the bore is $\frac{9}{16}$ inch. Its period is about 1695.

A few remarks on the work of Jo. Stuart, the maker of the last-described pistol, may not be out of place on this occasion. The place where this craftsman worked has not yet been ascertained, but as all the other examples made by him that I have come across are of steel and have the heart-shaped butt, it would seem that his locality was somewhere in the east or north-east of Scotland.

Referring back to the Table of Periods at the commencement of this paper, it will be remarked that it exhibits a very great overlapping of periods. The table shows that so late as the commencement of the last quarter of the seventeenth century the Early and Late Snaphance Locks and the Dog Lock were all being made at the one time. This peculiarity is even more strikingly illustrated in the work of Stuart, who, doubtless, would have to meet the wishes of his customers, some being conservative and others progressive.

Mr N. R. Colville's collection includes a specimen by Stuart with a Late Snaphance Lock dated 1691, and in my own collection is another dated as late as 1702; while in Castle Grant, Speyside, is a fine pair fitted with right- and left-hand locks of the ordinary Flint Lock system and dated 1701.¹ The example with the Dog Lock (fig. 6) may be placed in the last ten years of the seventeenth century. It would thus appear that Stuart at one and the same time was making firearms fitted with either the Late Snaphance Lock, the Dog Lock, or the Flint Lock.

I doubt if it is realised how valuable a record of Scotland's progress in art and craftsmanship we possess in the firearms of the sixteenth and seventeenth centuries, the large majority of which are dated. Unfortunately, it was only during the latter half of the seventeenth century that the gunmaker commenced to put on his name, instead of merely his initials, so that it is almost impossible to determine with accuracy the locality where the earlier pieces were made.

SUPPLEMENTARY NOTE ON FOUR PIECES OF CARVED WOODWORK FROM STIRLING CASTLE.

In last year's volume of the *Proceedings*, vol. lviii. p. 300, fig. 2, in describing a wooden panel with a lion passant carved on it, I stated that this object originally came from Stirling Castle. Since then,

¹ Illustrated in the *Catalogue of the Scottish National Exhibition, Glasgow, 1911*, p. 314, No. 14.

EARTH-HOUSE OR GALLERIED BUILDING NEAR DURNES. 221

Mr Thomas Ross, LL.D., F.S.A.Scot., has kindly pointed out that I was in error in stating that it had come from this place. He informs me that about forty years ago he saw it in the possession of an old woman in Dunblane, who told him that it came from the Cathedral there, and that about twenty years later he saw it again, but in the possession of Dr Stewart, Dunblane, who had obtained it at the dispersal of the effects of the old woman referred to. I purchased it from the dealer who bought it at the sale of Miss Stewart's effects. (See MacGibbon and Ross's *Ecclesiastical Architecture of Scotland*, vol. ii. p. 107.)