

Excavation and survey at the Giant's Grave, Slochd Measach, Nereabolls,
a Neolithic chambered cairn on the Isle of Islay, Argyll & Bute:
chronology, architecture, reuse and demise

Darko Maričević FSAScot* and Steven Mithen FSAScot†
with contributions from Inger M Berg-Hansen, Sarah Elliott, Rob Fry, Ruth Pelling and
Alison Sheridan FSAScot‡

<https://doi.org/10.9750/PSAS.152.1357>

* Department of Archaeology, University of Reading, PO Box 217, Reading, Berkshire RG6 6AH

d.maricevic@reading.ac.uk <https://orcid.org/0000-0001-8647-6250>

† Department of Archaeology, University of Reading, PO Box 217, Reading, Berkshire RG6 6AH /Islay

Heritage (SC046938) s.j.mithen@reading.ac.uk <https://orcid.org/0000-0002-3391-7443>

‡ Inger M Berg-Hansen: University of Cultural History, University of Oslo. Sarah Elliott: Department of
Archaeology & Anthropology, Bournemouth University. Rob Fry: Department of Archaeology, University of
Reading. Ruth Pelling: Historic England. Alison Sheridan: National Museum of Scotland.

Appendix 1

Stratigraphic matrices

Darko Maričević

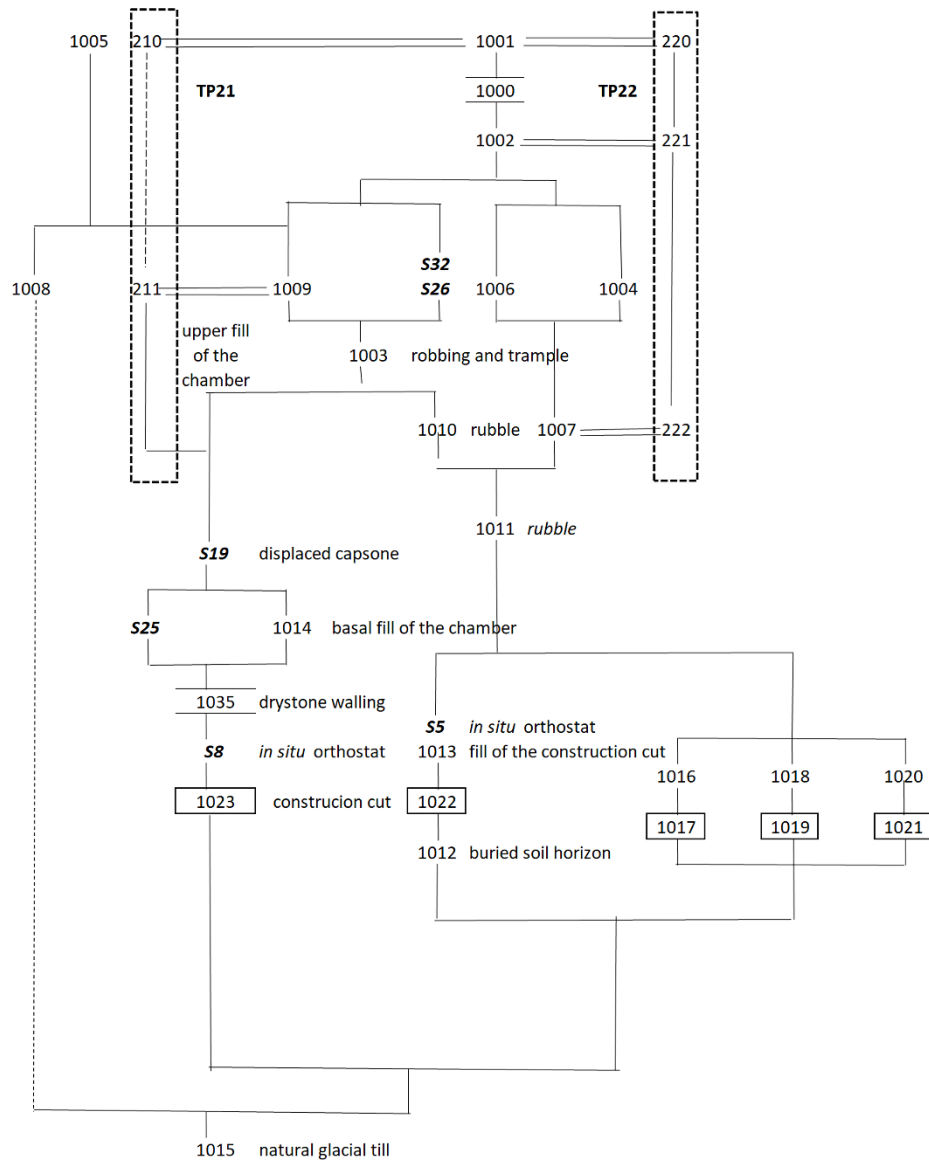

Illus A1.1 Trench 1 stratigraphic matrix

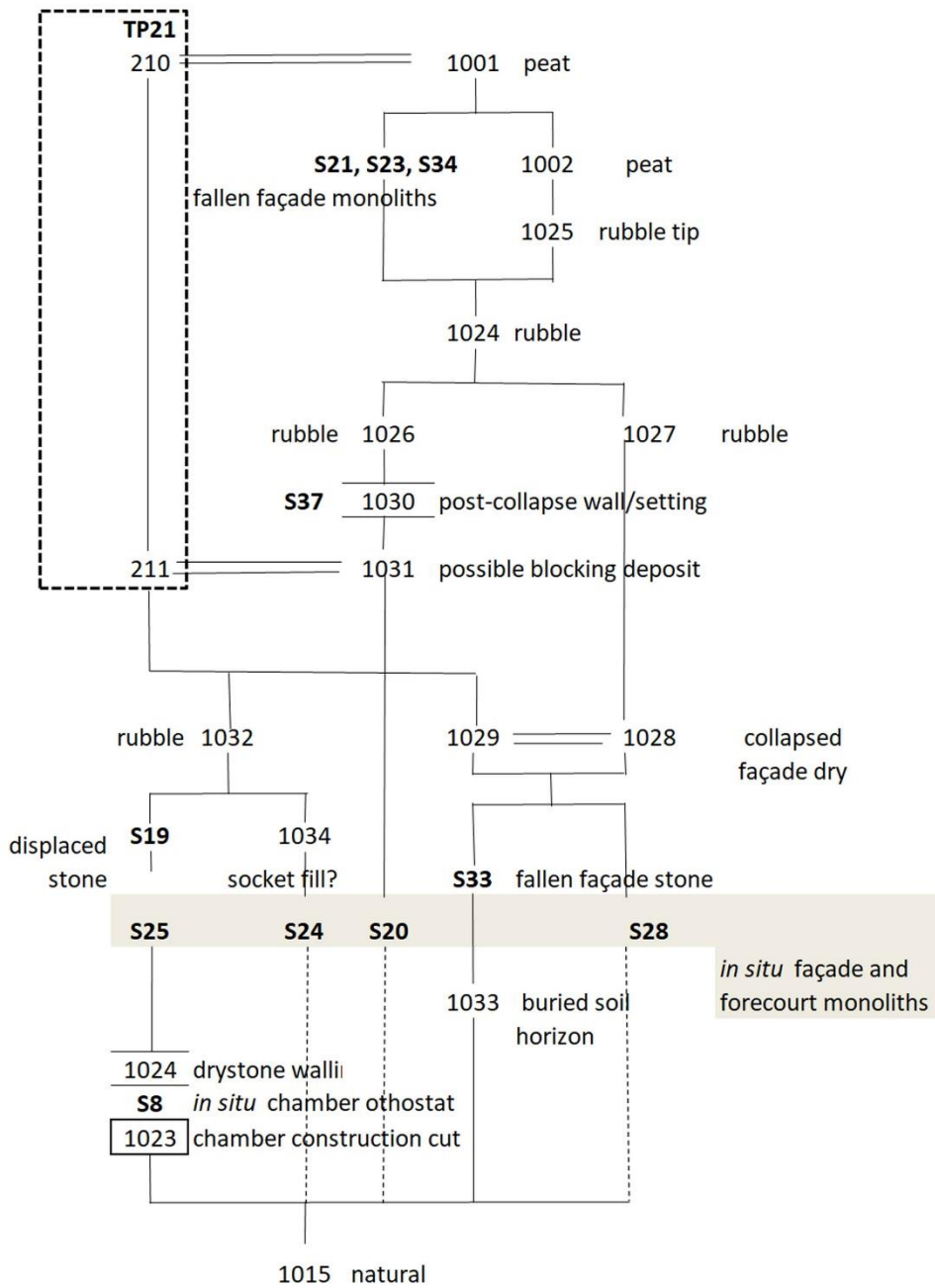

Illus A1.2 Trench 2 stratigraphic matrix

Trench 3

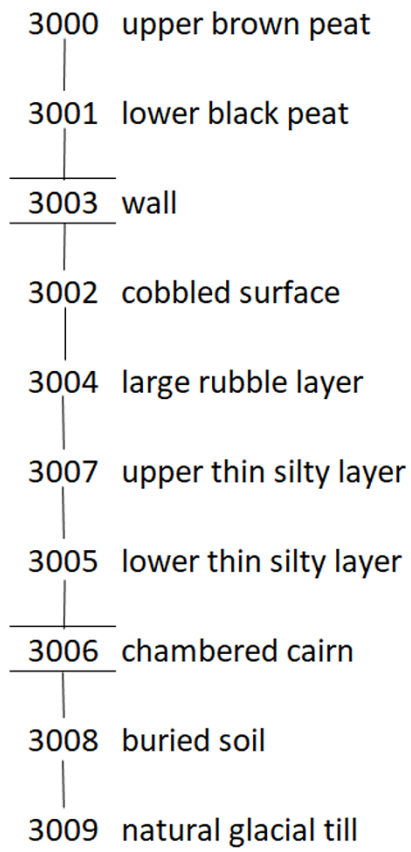

Trench 5

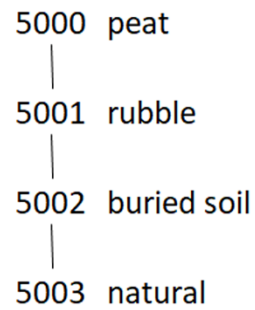

Illus A1.3 Trenches 3 and 5 stratigraphic matrices

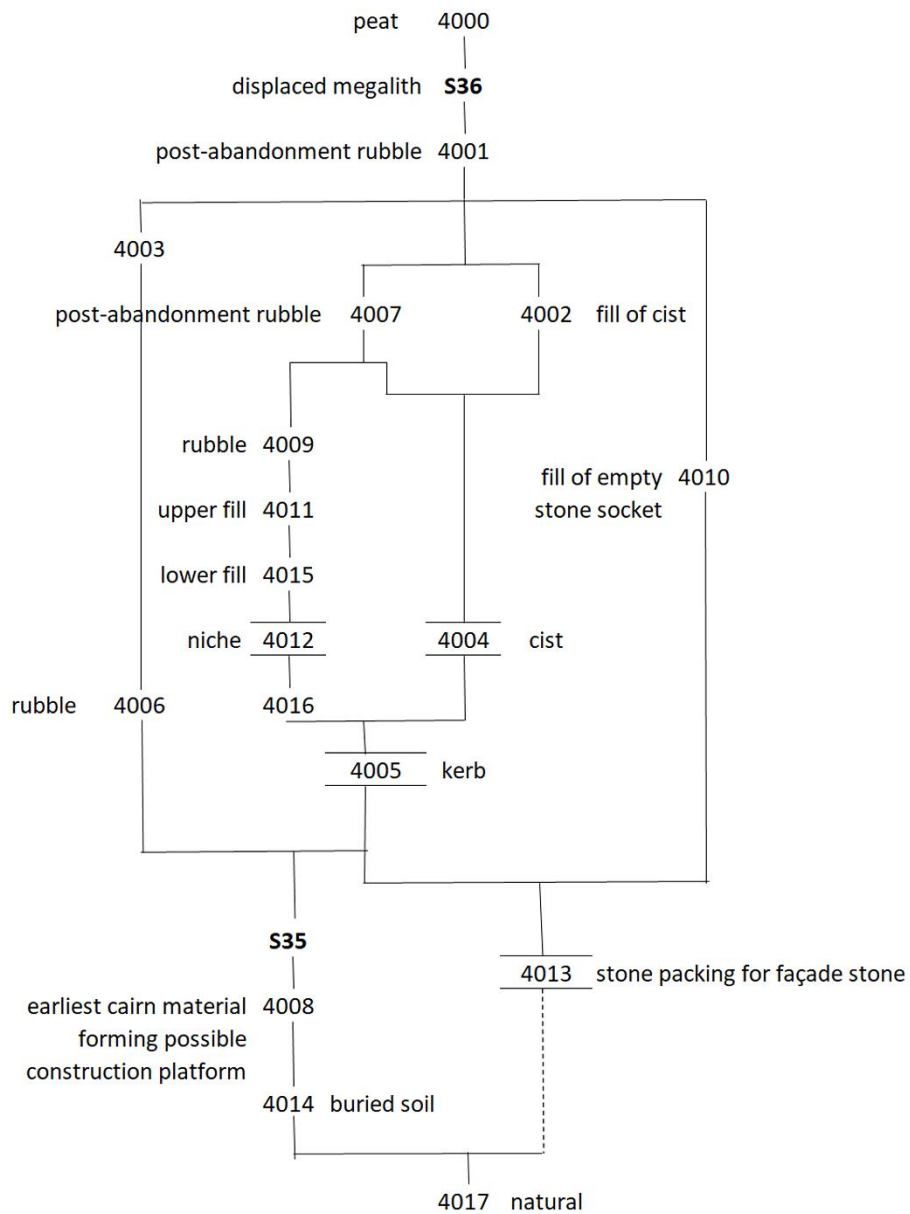

Illus A1.4 Trench 4 stratigraphic matrix

Appendix 2

A2. Micromorphology

Sarah Elliott

Micromorphological samples were taken during excavations from Trenches 2 and 5 for thin section production and analysis (Illus 16, 22C). The micromorphology samples were processed by Terrascope (<http://terrascope-tss.com/>) using standard procedures for thin section production onto large format glass slides (139x68mm). For each identifiable stratigraphic layer observations were made in plane polarised and cross polarised light (PPL and XPL). at both low and high magnifications (x40, x100, x200 and x400). The attributes were identified and recorded following standardised published terminology and descriptive criteria (Bullock et al. 1985; Courty et al. 1989; Stoops 2010).

A2.1 Sample SA194 in Trench 2

Trench 2 contained a sequence of rubble deposits with fallen and displaced megaliths. Deposit (1033) below fallen façade stone S33 was sampled for micromorphological analysis (Illus 16) to determine whether it was a naturally formed buried soil or an artificially laid surface in the forecourt of the chambered cairn?

Results and discussion

Only one unit was identified in SA194 (Illus A2.1), although areas of darker organic staining were present (Illus A2.2), as well as amorphous organic material (see detailed images in Illus A2.1). The upper boundary of the unit is darker and more humic and contains many compaction voids in the form of planes and channels (see detailed images in Illus A2.1) in addition to pseudomorphic plant voids where plant material has decayed (see detailed images in Illus A2.1). The matrix contains fine organic material as well as areas of humic organic staining.

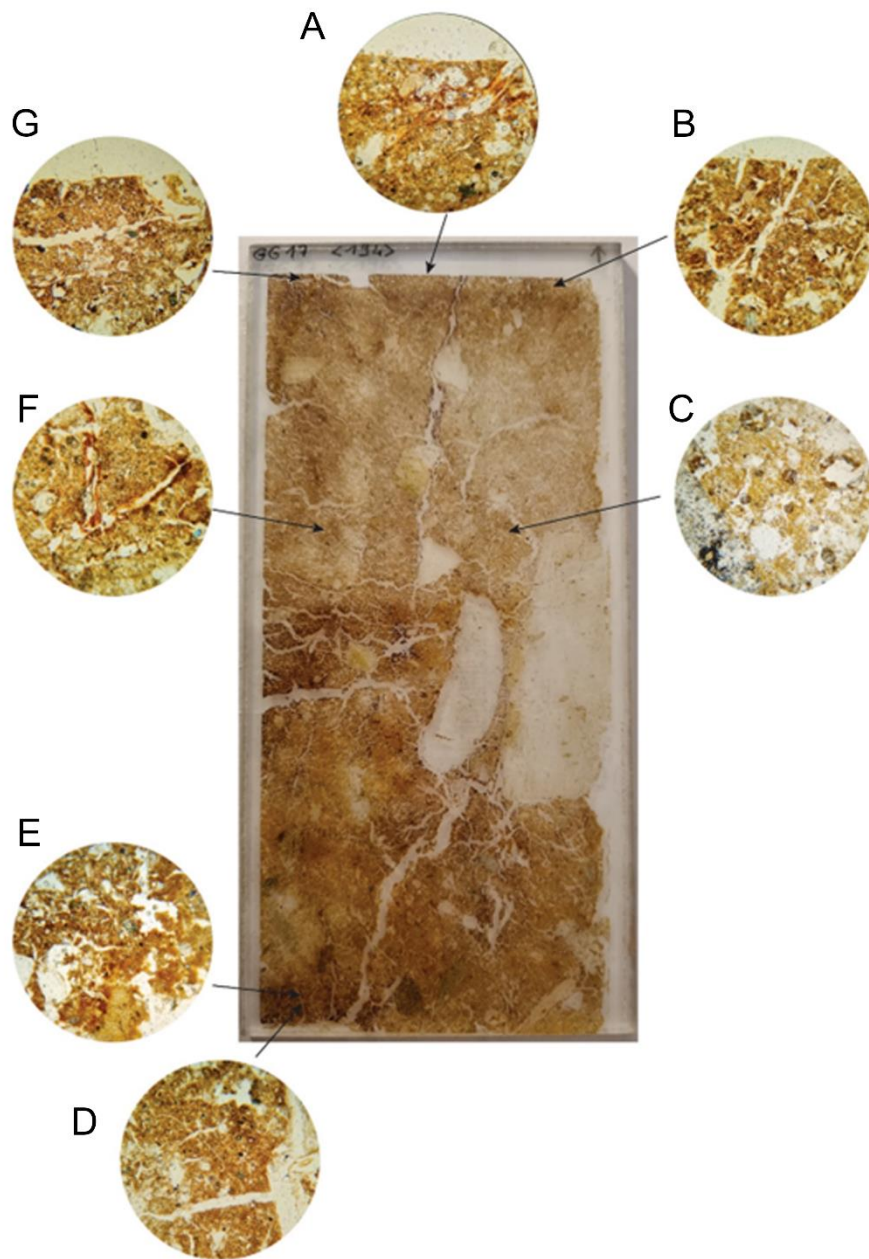

Illus A2.1 Sample S194, Trench 2. Thin section scan with details highlighted. A - Compacted, darker humic upper boundary, B - organic rich plant voids, C -humic areas with compaction voids, D -amorphous organic material, E -compaction voids in humic organic material, F -organic material and amorphous organic material, G - pseudomorphic plant voids with residual organic material. (Image by Sarah Elliott)

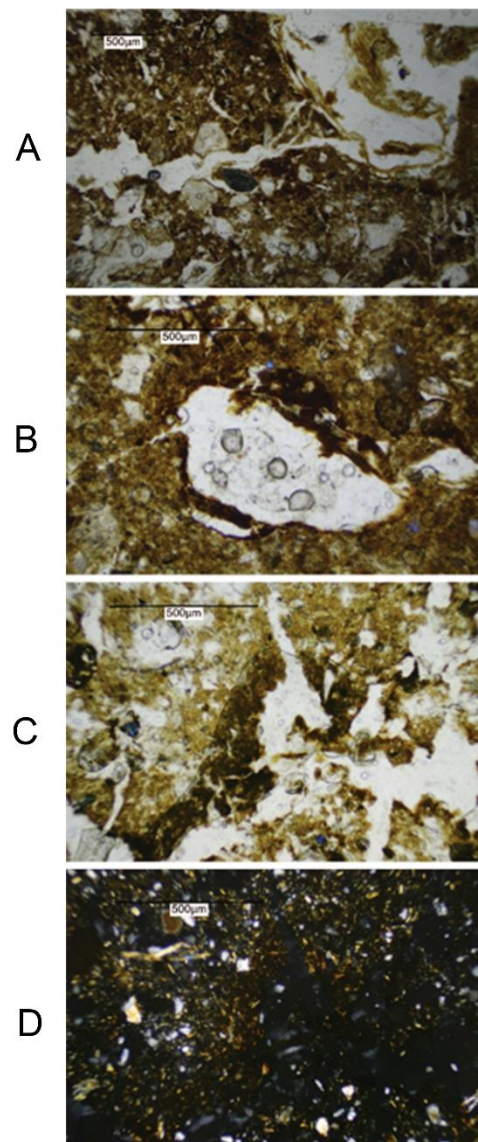

Illus A2.2 Photomicrographs from sample S194, Trench 2. A- magnified view of horizontal compaction void/ channel and residual organic material in plant void, B -finely humic clay lined void typical of buried soil horizons, C - humic staining in PPL (darker material), D - humic staining in PPL (red/brown material). (*Image by Sarah Elliott*)

Microstructure alterations from compaction in the form of planes and channels can be indicative of trampled material (Illus A2.2). However, other features usually associated with trampled deposits such as laminations, bedding and layering (Rentzel et al. 2017) were not identified. Other common trample features include horizontally orientated coarse components, orientated parallel to the boundary, but none of these features have been identified in SA194.

Horizontally orientated deposits can also be a feature of a deliberately laid and spread surfaces in addition to smooth distinctive boundaries, with minimal voids in the microstructure. The compaction of a laid surface can vary according to the natural materials utilised, however the dense compacted nature with smooth boundaries (Shillito and Ryan 2013) which are exhibited in laid surfaces are usually clear under magnification. There are no obvious features to indicate that this surface was deliberately laid.

A2.2 Sample SA166 in Trench 5

Trench 5 was located c.20m south of the cairn. A full sequence of deposits excavated in the trench were sampled in micromorphology sample SA166 for analysis (Illus 22). The question asked from this sample was whether deposit (5002) accumulated through natural processes, such as colluviation, or through anthropogenic action?

Results and discussion

Four units (U1-U4, Illus A2.3) were identified in SA166, representing excavated contexts (5000), (5001), (5002) and (5003). The uppermost unit (U4, context 5000) is only present c.1cm in the uppermost section of the slide. Contexts (5001) and (5002) are captured in their entirety with both boundaries for these contexts present within the thin section (U2 and U3, Illus A2.3). Finally, context (5003) is captured to a thickness of c.4-5 cm in the bottom of the thin section with only its upper boundary captured in the slide (Illus A2.3).

The lowest unit (5003), U1, is characterised by angular to sub-angular rocks and minerals with some clay coated voids. In this unit there are some dense areas, but also some looser areas particularly where the material has been post-depositionally affected by root action. Above this, (5002), U2, is also characterised by angular to sub-angular rocks and minerals and contains clay coated voids (Illus A2.3 and A2.4). This deposit is looser and less dense than the deposit below. Above (5002), is (5001), U3 which represents a particularly unsorted deposit with larger rock fragments, a higher percentage of rocks and minerals (Illus A2.4). Overall, this unit is darker with less voids, and is slightly more compact than layers below. The uppermost unit which is only represented by c.1cm of the deposit is the lowermost portion of (5000), U4. This deposit is much darker and denser than the other units and contains less minerals and rocks. The microstructure is represented by voids from compaction and deflation of organic material in the form of planes and channels (Illus A2.4).

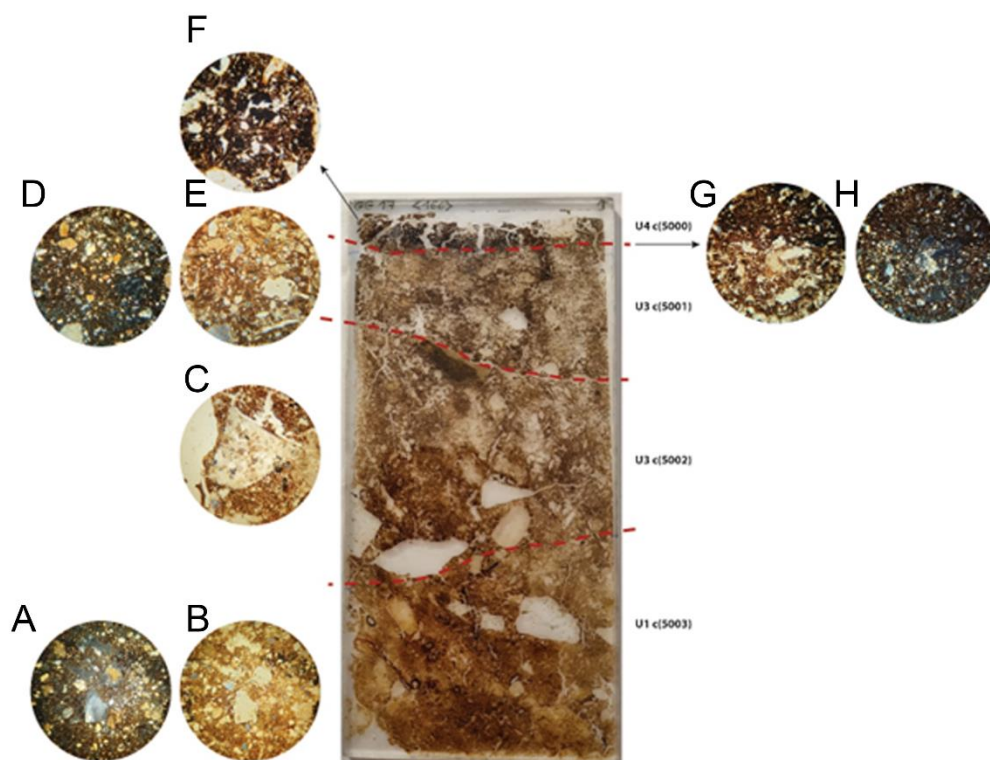

Illus A2.3 S166, Trench 5. Thin section scan with details for each unit highlighted. A (XPL) and B (PPL) – U1, unsorted coarse matrix with minerals and rock fragments, orangey-brown in colour; C - U2: PPL, Unsorted coarse matrix with minerals and rock fragments, mid-brown in colour, more voids than U1; D (XPL) and E (PPL) – U3, darker and more compacted than U2; F - U4, dark humic peat deposit; G (PPL) and H (XPL), detail of boundary between peat (5000), U4, and underlying deposit (5001), U3, showing clear/smooth boundary where dense compacted humic peat sits on the more mineral rich underlying context. (Image by Sarah Elliott)

The lower two units are similar in composition (U1 and U2, Illus A2.3) and represent unsorted material with rock fragments and minerals which vary in size. Unit 1 (5003) is slightly orangey brown in comparison to Unit 2 (5002), and the Unit 2 (5002) matrix is looser and slightly less dense than Unit 1 (5003). During excavation (5003, U1) was identified as glacial till and (5002, U2) was hypothesised to be colluvial in origin. While alluvial, colluvial and wind-blow material can be separated on the basis of particle roundness and sorting, the distinction between colluvium and glacial till is less evident. Both have common features such as coarse particles, poorly sorted and are heterogeneous in appearance. Particles and rock fragments representing glacial till may be smoother whereas colluvium may be more angular. These units in SA166 either represent two colluvial events, or glacial till beneath colluvium. U3 (5001) is the rubble layer which sits beneath a very organic peat deposit, U4 (5000).

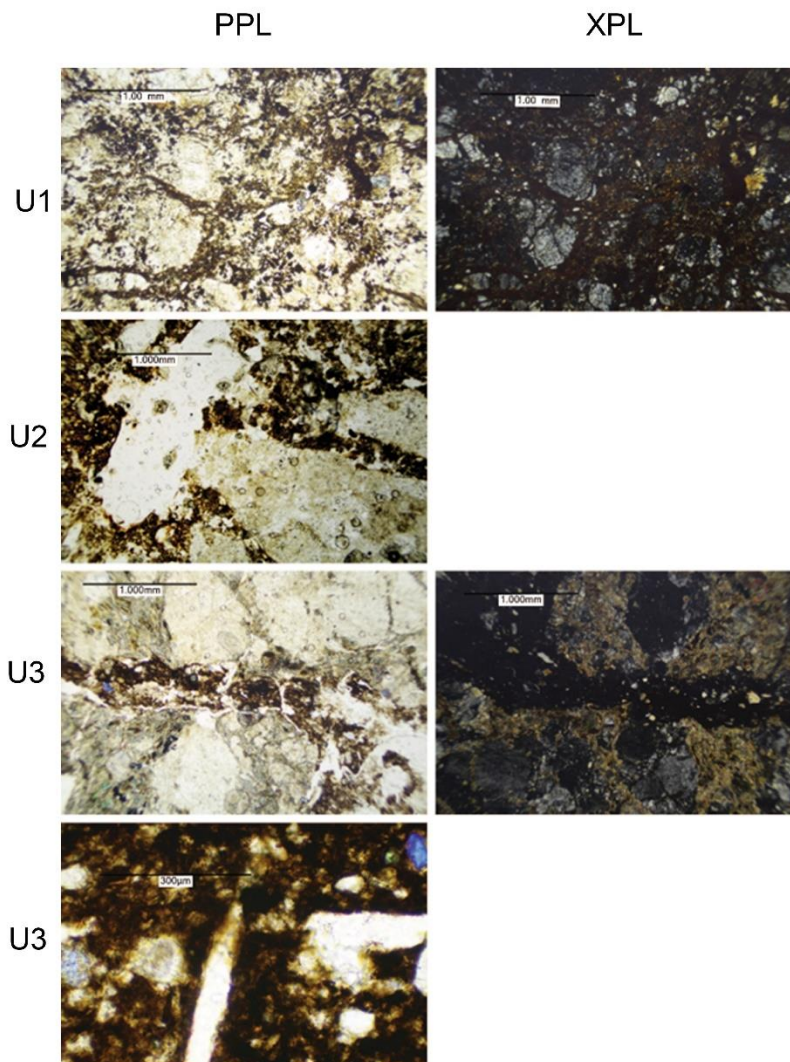

Illus A.2.4 S166. U1 - (5003) rock and mineral rich glacial till or colluvium; U2 - (5002) similar in appearance to above, rock and mineral rich colluvium, U3 - (5001) larger rock fragments in rubble layer embedded in silty clay; U3 - pseudomorphic plant voids in dense humic peat. *(Image by Sarah Elliott)*

A2.3 Conclusions

SA194 from Trench 2 has no evidence for trample, deliberately laid surfaces, or any anthropogenic material. Context (1033) consists of a compacted organic rich layer which represents a buried land surface preserved beneath megalith S33. There are a range of organic features exhibited at high magnification including organic staining, amorphous organic material, pseudomorphic plant voids and residual preserved organic material.

Sample SA166 from Trench 5 was taken to specifically investigate context (5002). There is little distinction between (5003) and (5002) with a very diffuse and irregular boundary between the two. The only observable difference between these contexts is a slight colour change and looser microstructure in (5002). There is no evidence for anthropogenic intervention or alteration. These contexts represent natural formation. Units 1 and 2 (5003, 5002) are either colluvium or glacial till beneath colluvium. These deposits are not deliberately laid or altered at all.

Appendix 3

Charred plant remains

Ruth Pelling

Whole earth flotation samples (30l) were collected from each deposit during the excavation, as well as a series of spot charcoal samples. The flotation samples were processed by mechanical flotation, with flots collected onto a 0.25mm mesh and residues on a 0.5mm mesh. Flots and residues sorted for wood charcoal and other organic macrofossils suitable for radiocarbon dating. Spot samples were cleaned by hand using a dry brush and charcoal separated from the soil.

Overall 62 environmental samples contained charcoal (Table A3.1). Nutshell was present in three sample (from two contexts), while a poorly preserved grain of *Hordeum vulgare* (barley) was found in only one sample. The charcoal analysis was limited to identifying suitable charcoal for C14 dating and therefore not all charcoal was identified beyond the level of ring or defuse porous and priority was given to contexts of interest for stratigraphic reasons. Standard procedures were followed for identification and fragments mounted in a sand bath for examination using an Olympus BHX high power, light-reflecting microscope, at magnifications of between x100 and x500. Identification criteria follow the text and keys given in Schweingruber (1990) and Hather (2000) and by comparison with the Historic England Seed and Wood and Charcoal Reference Collection (held at Fort Cumberland, Portsmouth). Nomenclature follows Stace (2010). Charcoal fragments were first separated into groups based on the distribution of pores in transverse section. This method is sufficient to identify *Quercus* sp. (oak), which is ring porous, and mature heart wood fragments, which are unsuitable for dating. The identification of defuse porous shorter-lived wood (with few growth rings), or complete roundwood with preserved pith and bark were prioritised. Defuse porous fragments were further fractured and examined in radial longitudinal section and tangential longitudinal section if there was sufficient material to do so.

Positive identification to genus or species was hampered by the poor condition of much of the material. The small number of charcoal fragments in most samples limited choice and the separation of some taxa, such as *Corylus* and *Alnus* (hazel and alder) or *Erica* and *Calluna* (heaths and heather) is difficult if diagnostic features are not encountered. The use of ‘cf.’ indicates uncertainty of identification. Cereal grain and nut shell were prioritised for dating where found.

A total of seven taxa or taxa groups were identified: *Calluna/Erica* including *Calluna vulgaris* (heather), cf Maloideae (a taxonomically similar group of fruit trees including hawthorn apple, pear, whitebeams/rowan), *Salix/Populus* sp. (willow/aspen), *Corylus avellana* (hazel), *Alnus glutinosa* (alder), *Prunus* sp. (blackthorn, cherry, bullace), and *Quercus* sp. (oak). The remaining taxa identified as ‘defuse porous’ could be of any of the above taxa with the exception of *Quercus*. The range of taxa indicates the exploitation of both woodland, and heathland resources. The fragments of *Corylus avellana* nutshell may represent food waste but could also derive from fuel wood. The single grain of *Hordeum*

vulgare from the post-abandonment rubble deposit inside the chamber was the only indicator of cereal use from the site.

Sample No.	Sample type	Volume	Context No.	Trench no.	Charcoal_Q (+=1-5, ++=6-25, +++=>25)	Species ID	Other remains	Radiocarbon date
100	flot	22	1010	1	+++	Defuse porous	quartz	n/a
101	flot	20	1007	1	+	<i>Calluna/Erica</i> sp.	modern organic remains from peat, quartz	n/a
102	flot	20	1003	1	+	Defuse porous	beetle body, other modern organic remains from peat, quartz	n/a
105	spot	n/a	1007	1	+	Indeterminate	n/a	n/a
106	flot	18	1004	1	+++	Defuse porous	modern organic remains from peat, quartz	n/a
110	flot	6	1011	1	+	Defuse porous	quartz	n/a
111	flot	13	1009	1	+++	Defuse porous	possible waterlogged wood fragments	n/a
112	flot	25	1011	1	.+	Defuse porous	quartz	n/a

118	flot	22	101 0	1	+++	1x <i>Calluna/Erica</i> sp., defuse porous	mineral encrusted	n/a
119	flot	20	300 7	3	+	cf. Maloideae	quartz	OxA-40052
120	spot	n/a	100 9	1	+	Barley grain (<i>Hordeum vulgare</i>)	none	n/a
121	spot	n/a	100 9	1	+++	<i>Calluna vulgaris</i>	quartz	n/a
123	flot	18	101 2	1	+	Indeterminate	rounded stones, quartz	n/a
125 a	flot	12	101 3	1	+++	<i>Calluna/Erica</i> sp.	quartz	OxA-40048
125 b	flot	12	101 3	1	+++	<i>Corylus avellana</i>	quartz	OxA-40130
126	spot	n/a	101 3	1	+	<i>Corylus avellana</i>	none	n/a
127	flot	14	101 4	1	++	Defuse porous	rounded stones, quartz, mould	n/a
130	spot	n/a	101 4	1	+	<i>Salix/ Populus</i> sp.	none	n/a
132	spot	n/a	101 4	1	+	<i>Salix/ Populus</i> sp. (mature wood)	none	n/a
134	flot	16	101 4	1	+++	Defuse porous	insect pupa case (recent), quartz, rounded stones	n/a
136	flot	4	101 8	1	+	<i>Calluna/Erica</i> sp.	quartz	OxA-40129

139	flot	32	101 4	1	++	Defuse porous	quartz	n/a
140	flot	7	101 4	1	++	<i>Quercus</i> sp., Defuse porous	quartz	n/a
141	spot	n/a	101 2	1	+	Indeterminate	none	n/a
142	flot	12	101 3	1	++	Defuse porous	rounded stones, quartz	n/a
143	spot	n/a	101 3	1	++	<i>Corylus avellana</i> sp.	none	n/a
144	spot	n/a	300 8	3	+	<i>Corylus avellana</i> sp.	none	OxA- 40051
145	flot	13	300 8	3	+	<i>Corylus avellana</i> (nutshell), Defuse porous charcoal	none	OxA- 40131
146	spot	n/a	300 8	3	+	2x <i>Alnus glutinosa</i> ; 1x <i>cf. Corylus avellana</i>	none	n/a
147	spot	n/a	300 8	3	+	<i>cf. Corylus avellana</i>	none	n/a
150	flot	4	400 3	4	++	Indeterminate	charred peat fragments	n/a
153	flot	19	102 5	2	++	<i>Calluna/Erica</i> sp.	quartz	n/a
155	flot	20	500 2	5	++	<i>cf. Calluna/Erica</i> sp.	quartz	SUERC- 97389 (GU57540)
160	flot	25	500 2	5	++	2x <i>Calluna/Erica</i> sp., otherwise indeterminate	slate?, quartz	SUERC- 97388 (GU57539)

162	flot	n/a	500 2	5	++	Defuse porous	none	n/a
164	flot	20	102 8	2	+	Indeterminate, Defuse porous	possible seeds, quartz	n/a
165	flot	19	400 7	4	+	Indeterminate	possible recent twigs	n/a
167	flot	2	400 7	4	++	cf. <i>Calluna/Erica</i> sp.	possible seeds, quartz	n/a
168	flot	6	102 9	2	+	Indeterminate	ceramic	n/a
169	flot	2	400 2	4	+	2x cf. <i>Calluna/Erica</i> sp., 3x Defuse porous	none	OxA- 40134
170	flot	25	400 6	4	+	Indeterminate	possible recent twig	n/a
171	spot	n/a	102 9	2	++	<i>Calluna/Erica</i> sp.	none	n/a
172	flot	17	400 9	4	++	Defuse porous; Indeterminate	possible seeds, quartz	n/a
173	flot	17	103 1	2	++	Defuse porous	quartz	n/a
174	flot	18	102 9	2	++	<i>Salix/ Populus</i> sp. (mature wood)	quartz	n/a
175	flot	10	401 0	4	++	Indeterminate; Defuse porous	quartz, ceramic	n/a
176	spot	n/a	400 9	4	+	Indeterminate	none	n/a
179	spot	n/a	401 4	4	++	Indeterminate	none	n/a

180	spot	n/a	401 4	4	+	Indeterminate	none	n/a
181	flot	3	401 1	4	++	cf. <i>Calluna/Erica</i> sp.	quartz	OxA- 40133
182	spot	n/a	401 1	4	+	Defuse porous	none	n/a
183	flot	8	401 5	4	+	<i>Calluna/Erica</i> sp.	possible seeds, quartz, ceramic	OxA- 40104
184	spot		103 3	2	++	Defuse porous	none	n/a
185	flot	25	401 4	4	+	Indeterminate	quartz	n/a
186	spot	n/a	401 5	4	+	Indeterminate	none	n/a
187	spot		103 3	2	+	<i>Prunus</i> sp.	none	OxA- 40049
188	flot	16	103 4	2	+	Defuse porous	quartz	n/a
189	spot	n/a	102 8	2	+	<i>Calluna/Erica</i> sp.	none	n/a
190	flot	25	103 3	2	++	<i>Corylus</i> <i>avellana</i>	none	OxA- 40050
191	flot	14	401 4	4	++	<i>Corylus</i> <i>avellana</i> (nutshell); indeterminate charcoal	none	OxA- 40132
192	flot	3	400 5	4	+	cf. <i>Calluna/Erica</i> sp.	none	OxA-X- 3070-31
193	flot	4	401 6	4	++	<i>Calluna/Erica</i> sp.	none	n/a

Appendix 4

Description of pottery sherds and vessels

Alison Sheridan

A4.1 Pot 1 (SF27, 4015; Illus 25A).

Pot 1 was found in the central part of the excavated eastern half of the 'niche', among the lower fill (4015), with the interior surface of the surviving part of the pot uppermost. The weight of the overburden had crushed (though not deformed) the pot, and it is unclear whether the missing pieces remain in the unexcavated part of the niche, had decayed entirely, were removed or destroyed when the later pot SF25 was deposited in the upper fill of the niche. The last interpretation seems unlikely, given that there was a gap of several centimetres of fill between the two sets of sherds. It is likely that the pot had originally been deposited upright on the floor of the niche and then toppled over when the niche filled up (or was filled) with sediment; this scenario accounts for the survival of a large part of just one side of the pot. Organic material from the lower fill of the niche produced a radiocarbon date of 3410 ± 19 BP (OxA-40104, 1751–1625 cal BC) and it is reasonable to assume that the pot's deposition was broadly contemporary with this.

The vessel consists of 10 conjoining sherds that have been refitted to form a large part of one side of the pot, along with 28 non-conjoining sherds and four fragments from SF 27 and six sherds from environmental sample <183>. The reconstructed pot stands to a height of 128 mm and with estimated dimensions of: rim, 150 mm; carination (widest point of pot), c. 150 mm; and base, 70mm. The rim is gently pointed and slightly everted; the neck is upright and concave; the carination is gentle; and the belly slopes down to the flat base in a straight line. The exterior of the base is very slightly dished, and the base-wall junction in the interior is a continuous curve. The carination is located around 2/3 of the vessel's height. The wall thickness ranges from 7.5 mm at the centre of the base to 9.5 mm at mid-belly and 8.6 mm at mid-neck. Part of the exterior and interior surfaces of the neck had spalled off, and the fracture surfaces along the edge of the refitted segment of the pot are moderately to heavily abraded, confirming that the pot had indeed broken in antiquity.

The exterior is a mottled buff to mid-brown colour, with a salmon-pink patch on the neck and a very thin, discontinuous patch of black organic residue around the carination. The core is light grey and the interior ranges from buff to light grey, with a very small patch of thin black organic residue at the base. There is also orange staining from the peat, together with adherent fragments of the plant material from the peat. The surfaces had probably been wet-smoothed, although there are undulations on the exterior from the finger-shaping of the pot. There is a faint trace of a horizontal wipe-mark on the interior. The thin organic residue does not look to have been burnt on it may instead be the residue from the evaporation of the pot's original liquid contents.

The pot has been decorated with a combination of incised, nail-impressed and cord-impressed designs. On the interior of the rim there are traces of four horizontal lines of twisted cord impression, and a further four horizontal cord-impressed lines lie on and immediately below

the carination on the exterior. The maximum width of the cord impressions is c. 1.5 mm, and the cord had been S-twisted (Illus A4.1). In between the horizontal lines on the exterior are faint diagonal impressions. Those between the upper two lines had been incised, while those between the other lines had been made with a combination of finger- or thumbnail impressions, made with the left hand, and incisions. On the neck, between the uppermost horizontal line and the rim, is an incised lattice design.



Illus A4.1

Inclusions are very sparse, a density of < 3%, with microscopic quartz sand grains visible at the wall-base junction on the exterior of the pot. Rounded and sub-angular sockets on the interior may relate to organic filler that had burnt out, although no structure of the putative plant material can be detected. Otherwise, where fragments of stone can be seen, these are all within the peaty sediment that still adheres to some of the sherds.

A4.2 Pot 2, part of SF17, 4002; Illus 25B.

Pot 2 was found lying on its side, crushed, in the cist 4004. It had probably been deposited upright, at the southern end of the cist. Short-lived species charcoal from the fill of the cist produced a date of 2828 ± 26 BP (OxA-40134, 1054–905 cal BC), and this is consistent with the style of the pot as a Late Bronze Age vessel.

This is a complete vessel, deformed into an oval shape in plan from the pressure of overburden. The conjoining sherds have been refitted, and gaps filled. There are seven loose

sherds that could not easily be refitted to the rest of the pot, but which are entirely compatible. The pot stands to a height of 143 mm. Its rim measures c. 125 x 108 mm, so the original diameter will have been between these, perhaps c. 120 mm. The base, which is less distorted than the rest of the pot, has a diameter of c. 70 mm. Wall thickness ranges from c. 17 mm at the base to as thin as 6.8 mm. The rim is upright, pointed, and has a shallow external bevel and a steep internal bevel. The neck is straight and virtually upright. A very low horizontal cordon, probably made by applying and moulding a thin fillet of clay, runs around the pot around 2/3 of its height, dividing the upright neck from the gently tapering belly. The base is minimally dished on the exterior and has a rounded junction with the wall on the interior. The pot is undecorated, save perhaps for three very faint diagonal incised lines, running down the outside of the neck from the rim.

The exterior is a mottled mid-brown, reddish-brown and grey-brown colour; the core is blackish-grey; and the interior is a mid-brown to dark grey-brown. It is impossible to tell whether any of the darker parts of the interior are that colour because of staining by organic residues from the pot's original contents. The exterior surface, now pitted and degraded on the side that had been in contact with the cist floor, may originally have been coated with a thin slip although this has not concealed the irregularities on the surface, including protruding lithic inclusions. Other inclusions protrude through the interior surface, which does not look to have been coated in slip.

Inclusions consist of abundant, sub-angular fragments, up to c. 10 x 5 mm in size and at an estimated density of 10–15%, of a soft, finely crystalline grey-brown stone with black speckles. This is likely to be a form of sandstone which, in places, has rotted out to leave sub-angular sockets. Also present are a very few sub-angular fragments of white quartz, one with dark mineral inclusions.

A4.3 Pot 3, part of SF17, 4002 and all but two sherds of <152>; Illus 25C

This comprises 21 sherds from SF17 and 22 sherds and three fragments from environmental sample <152>; one set of four sherds and one set of two sherds conjoin and have been refitted. The sherds are from the upper part of the body, and represent around a third of the whole pot. This vessel is similar in shape to Pot 2, and just a little larger at its rim, with an estimated rim diameter of 135 mm and a maximum diameter, at its neck-belly cordon, of c. 150 mm. If, as seems likely, the proportions of this pot match those of Pot 2, its height can be extrapolated as c. 123 mm. The wall thickness is c. 8 mm at the neck and c. 8.5 mm at the upper belly; its maximum thickness, at the cordon, is c. 9.5 mm. The rim is upright and pointed, with a shallow exterior bevel and a steep, concave interior bevel, its lower edge accentuated by a hollow formed by running a finger around the inside of the pot. The neck is straight and upright, or virtually so. The junction between the neck and belly is marked by a low applied cordon, rounded in profile, this also represented by a piece had become detached. The pot is undecorated.

The exterior is a dark brown colour, with discontinuous patches of what may be a very thin blackish organic residue on one part of the neck. The core is dark grey-brown with yellow-brown patches and the interior is dark brown and dark grey-brown. The surfaces had been

smoothed but are slightly uneven, and both have a slip-like appearance, but whether this was due to the application of a thin slip, or else to wet-smoothing, is unclear. Both surfaces are, however, pock-marked by the leaching out of some of the lithic inclusions. These consist of sub-angular fragments, up to 10 x 6.5 mm, of the same fine-grained, speckled stone as seen in Pot 2. The inclusion density is 10–15%.

The two sherds from environmental sample <152> that do not belong to either Pot 2 or Pot 3 are described separately below.

A4.4 Pot 4, SF25, 4011; Illus 25D; sherds from <175>, 4010, may also belong.

This pot was found crushed and on its side among the upper fill of the niche, several centimetres above the Early Bronze Age Pot 1. It was probably originally deposited upright, before tipping over and being crushed by the overburden. Short-lived charcoal from the upper fill of the niche produced a radiocarbon date of 2631±26 BP (OxA-40133, 828–778 cal BC at 95.4%) and it is reasonable to assume that the charcoal may have been broadly contemporary with the pot.

The pot comprises 39 sherds and 10 fragments from SF25, plus three small sherds from environmental sample <175>, which may belong, despite not being found in the niche. Of the SF25 sherds, one set of six and one set of four sherds conjoin; all but one of these sherds have been refitted. The base sherds were particularly friable, disintegrating during the conservation and illustration processes. Around two thirds of this pot survive, demonstrating strong similarities with Pots 2 and 3 from the cist. The estimated diameters are as follows: rim c. 140 mm; maximum diameter at the neck-belly cordon, c. 150 mm; base, c. 85 mm. The estimated height is c. 133 mm. The wall thickness ranges from 6.5 mm at the lowest part of the neck to 9.9 mm at the cordon. The rim is flattish-rounded and upright, with a near-imperceptible steep bevel on its exterior and an uneven seam on the interior where the clay used to make the rim has been folded over. On the exterior, below the bevel, the neck is concave. The junction between the neck and belly, which lies around three-quarters of the height of the pot, is marked by a prominent, pointed horizontal cordon which has been applied. Below that, the belly curves gently in to the base, which is flat inside and out.

The exterior colour ranges from light brown to dark brown; the core is dark grey-brown; the interior ranges from yellowish-buff to dark brown. The surfaces had probably been wet-smoothed but are uneven, and much of the exterior surface at the base and lower belly had spalled off. In some areas the surfaces are pock-marked from the dissolution of the lithic inclusions. There are hints of possible very thin, discontinuous, blackish-brown organic residues on the exterior of the neck and on parts of the interior; if these are indeed organic residues, they would be from the evaporation of the pot's former contents, rather than burnt-on residue. Inclusions consist of the same stone as seen in Pots 2 and 3 – namely a rotten sandstone, in all probability. These range up to 8 x 6.5 mm, are sub-angular, and occur at a density of 10–15%.

A4.5 Pot 5, SF24 and <168>, 1029; Illus 25E.

The remains of this pot were found standing upright with its base on a slab in the lowest level of the rubble deposit (1029), in the forecourt (Trench 2). Radiocarbon dates from elsewhere in the excavation date the top of post-abandonment rubble, context (202) in TP20 on the SE side of the cairn, to 2300±30BP (Beta-421419, 408-211 cal BC) and 2390±BP (Beta-421418, 724-394 cal BC) and the base of the rubble, context (1018) in Trench 1, on the NW side of the cairn to 2414±25 BP (OxA-40129, 734–402 cal BC) – suggesting an Early Iron Age date for this pot, and that is consistent with its design, as discussed below. Typologically, the pot is a vase-shaped Food Vessel that is late in the Food Vessel tradition, as discussed below.

This comprises, from SF24, 24 conjoining sherds, of which 21 have been refitted, to form the lower half to two-thirds of the pot, along with a further eight non-conjoining sherds that are either from the same part of the pot or from further up, plus a single rim sherd (Ilus 45). There are also three small sherds from the same pot that were retrieved from processing environmental sample <168>. The base of the pot is flat, with a slight rounded pedestal on the exterior and a rounded base-wall junction on the interior. Its external diameter is c. 83 mm. The belly swells out above the pedestal to a maximum diameter of c. 150 mm, then appears to narrow slightly but it could have splayed out a little at the rim, which is gently pointed and has a steep, slightly concave internal bevel. The rim sherd is too small for an accurate estimation of the rim diameter, but it could be c. 150 mm. The reconstructed part of the pot is 129 mm high and the overall height may have been c. 165 mm. The wall thickness is 14.2 mm at the base, and ranges from 8.2 mm to c. 16 mm further up the body, and 8.8 mm at the bottom of the rim bevel. The pot is undecorated (at least as far as its surviving parts are concerned).

The exterior is a mottled buff, pinkish brown and light to mid brown, with a broad band of thin black organic residue extending over part of the belly from its widest point. The core is blackish and the interior ranges from buff to light grey-brown to medium grey-brown. The surfaces had been smoothed, with one patch of pebble- or spatula-smoothing over the lower belly on the exterior, but they are pocked from the partial disintegration of some of the lithic inclusions and there has been some surface abrasion to parts of the exterior. The thin organic residue on the exterior could be the evaporated remains of the pot's former liquid contents; it does not appear to have been burnt on, as it is not an encrustation.

Lithic inclusions are abundant (with a density of c. 10–15%) and varied. They range from small, rounded pebbles of a dull grey-brown stone to sub-angular fragments, from c. 1 x 1 mm to c. 8 x 7 mm, of the rotten dark brown, black-speckled stone – probably sandstone – as seen in Pots 2–4. There are also large, sub-angular fragments, up to c. 10.5 x 9 mm, of a slightly friable, speckled, off-white stone with black (possibly biotite mica) inclusions, and also a large, sub-angular fragment of white quartz. The inclusions protrude through both surfaces, but are more visible on the interior.

A4.6 Other pottery

The two sherds in the environmental sample <152> that do not belong to either Pot 2 or Pot 3 in cist (4004) are heavily abraded and lack both surfaces; the larger measures 30.8 x 17.3 x 8.6 mm and the smaller, 20.4 x 15.1 x 4.6 mm. They are from the same pot, which has very

abundant (c 25–35%) sub-angular lithic inclusions of the off-white, speckled stone as seen in Pot 5. It is impossible to gauge the size or shape of the pot from these two sherds. It is assumed that the pot is contemporary with Pots 2 and 3, making it of Late Bronze Age date.

Sherd SF20, from 4006, is an abraded, featureless body sherd lacking much of its exterior surface. It measures 27.9 x 35.0 mm and is c. 11 mm thick, with slightly reddish-brown surfaces and a dark grey core. It contains abundant sub-angular fragments (and sockets for disintegrated fragments), up to c. 6 x 4 mm, of the same rotten sandstone as seen in Pots 2–5; their partial disintegration has left the surfaces pocked. It is impossible to attribute this sherd to any specific period of activity although, according to the excavator, it could belong to the Early Iron Age period of activity, given the stratigraphic position of the context.

One sherd, lacking an SF or sample number, was found in 5002 in Trench 5, several metres to the south of Trench 4. This context is either the buried soil horizon or else colluvium; it underlies a layer of rubble that may have tumbled from – or been brought from – one of a number of structures uphill, including the chambered cairn. It is a featureless body sherd, lacking one surface (probably its interior), and it measures 30.6 x 25.8 x 7.6 mm. The sherd has a gentle curvature, suggesting that it may come from a slightly concave neck of a pot; the estimated diameter of the pot at this point is c. 170 mm. Two of its fracture surfaces are moderately abraded. The lithic inclusions are of two kinds: one is a dark rock with white inclusions (of quartz or feldspar), present as sub-angular fragments up to c. 5 x 4.8 mm; the other is a dark orange-brown rotten stone, probably a sandstone, which has mostly decomposed and left sockets. The overall density of inclusions is around 7.5–10%. It is impossible to attribute a date to this sherd.

The unfired clay from 3008 consists of several lumps of light brown clay which may have been kneaded and mixed with rounded and sub-angular pieces of stone. The softness of the clay suggests that it had not been fired. This does not have the characteristic wattle impressions of daub and its findspot location, in the buried soil horizon below the cairn kerb, raises the question of how, if at all, it had been used. Had there been a continuous layer of this material under the cairn, it could have been interpreted as a deliberate deposit, to create a ‘clean’ or ‘pure’ surface upon which to construct the monument. If it had been found between upright stones, then a function as luting material, to make the joint between the stones watertight, could be suggested. As it is, there is no obvious explanation for its presence – and it is also not certain whether it had been kneaded. It is sufficiently different from the sediment around it to have been noticed during the excavation, however.

Appendix 5

Table 1

Output from Bayesian model for dates (n=13) for Giant's Grave prehistoric sequence, excluding early modern peat dates, two dates from mixed colluvium in Trench 5 and two intrusive dates from Trenches 1 and 2. OxCal m4.4.4 (Bronk Ramsey 2021) using IntCal2020 (Reimer et al. 2020). See Illus 25.

Name	Unmodelled (BC/AD)			Modelled (BC/AD)			Modelled (BC/AD)			Modelled (BC/AD)			Indices				
	from	to	%	from	to	%	from	to	%	from	to	%	Acomb	A	L	P	C
Boundary End demolition/robbing							-400	-335	68.27	-449	-200	95.45					98
R_Date Beta-421419	-403	-266	68.27	-409	-211	95.45	-402	-380	68.27	-458	-352	95.45		124			100
R_Date Beta-421418	-513	-401	68.27	-725	-394	95.45	-461	-401	68.27	-516	-396	95.45		116			100
R_Date OxA-40052	-538	-416	68.27	-730	-408	95.45	-473	-410	68.27	-534	-406	95.45		109			100
R_Date OxA-40129	-516	-411	68.27	-734	-403	95.45	-472	-407	68.27	-525	-402	95.45		114			100
Phase Demolition/robbing																	

Name	Unmodelled (BC/AD)						Modelled (BC/AD)						Indices Amodel 131 Aoverall 1130.9				
Boundary Start demolition/robbing							-549	-437	68.2 7	-647	-412	95.45					99
Boundary End Bronze Age activity							-801	-620	68.2 7	-811	-494	95.45					10 0
R_Date OxA-40133	-812	-792	68.2 7	-828	-778	95.4 5	-813	-792	68.2 7	-830	-777	95.45		96.3			10 0
R_Date OxA-40134	-1011	-931	68.2 7	-105 4	-905	95.4 5	-1012	-932	68.2 7	-1055	-905	95.45		99.8			10 0
R_Date OxA-40104	-1743	-1642	68.2 7	-175 1	### #	95.4 5	-1742	### #	68.2 7	-1750	-1625	95.45		98.8			10 0
Phase Bronze Age activity																	
Boundary Start Bronze Age activity							-2260	### #	68.2 7	-2980	-1640	95.45					98
Boundary End Neolithic cairn activity							-3366	### #	68.2 7	-3477	-2834	95.45					98
R_Date OxA-40049	-3487	-3361	68.2 7	-349 6	### #	95.4 5	-3376	### #	68.2 7	-3494	-3346	95.45		105			10 0
R_Date OxA-40050	-3363	-3134	68.2 7	-336 8	### #	95.4 5	-3364	### #	68.2 7	-3371	-3121	95.45		122			10 0

Name	Unmodelled (BC/AD)						Modelled (BC/AD)						Indices Amodel 131 Aoverall 1130.9				
R_Date OxA-40130	-3502	-3370	68.2 7	- 351 6	### #	95.4 5	-3467	### #	68.2 7	- 3495	- 3358	95.45		89.5			10 0
Phase Neolithic cairn activity																	
Boundary Start Neolithic cairn activity							-3522	### #	68.2 7	- 3555	- 3363	95.45					99
Boundary End pre-cairn activity							-3601	### #	68.2 7	- 3618	- 3423	95.45					10 0
R_Date OxA-400051	-3623	-3383	68.2 7	- 362 9	### #	95.4 5	-3626	### #	68.2 7	- 3631	- 3509	95.45		106			10 0
R_Date OxA-40132	-3629	-3516	68.2 7	- 363 4	### #	95.4 5	-3630	### #	68.2 7	- 3636	- 3516	95.45		119			10 0
R_Date OxA-40131	-3756	-3648	68.2 7	- 377 1	### #	95.4 5	-3689	### #	68.2 7	- 3755	- 3638	95.45		109			10 0
Phase Pre-cairn																	
Boundary Start pre-cairn activity							-3757	### #	68.2 7	- 3925	- 3642	95.45					97
Sequence Giant's Grave																	

Table 2

Output from Bayesian model for dates (n=22) for the 4th millennium on Islay. OxCal m4.4.4 (Bronk Ramsey 2021) using IntCal2020 (Reimer et al. 2020). See Illus 27

Name	Unmodelled (BC/AD)			Modelled (BC/AD)			Unmodelled (BC/AD)			Modelled (BC/AD)			Indices Amode I 103.8 Aovera II 103.1	Acomb	A	L	P	C
	from	to	%	from	to	%	from	to	%	from	to	%						
Phase Islay 5th/4th mill. BC																		
Phase Storakaig																		
R_Date Beta-307788	-4221	-3985	68.2 7	-4231	-3975	95.4 5	-4222	-3988	68.2 7	-4231	-3979	95.4 5		98.7				99. 9
R_Date Beta-288431	-3982	-3811	68.2 7	-4041	-3799	95.4 5	-3988	-3945	68.2 7	-4044	-3850	95.4 5		112				99. 9
R_Date Beta-288429	-3976	-3809	68.2 7	-4037	-3797	95.4 5	-3973	-3847	68.2 7	-3981	-3820	95.4 5		106. 8				99. 9
R_Date Beta-307789	-3964	-3805	68.2 7	-3978	-3794	95.4 5	-3951	-3807	68.2 7	-3958	-3801	95.4 5		105. 5				99. 9
R_Date Beta-307790	-3945	-3799	68.2 7	-3962	-3715	95.4 5	-3856	-3776	68.2 7	-3928	-3716	95.4 5		93.9				99. 9
R_Date Beta-288430	-3786	-3656	68.2 7	-3933	-3647	95.4 5	-3775	-3657	68.2 7	-3795	-3651	95.4 5		109. 7				99. 8

Name	Unmodelled (BC/AD)						Modelled (BC/AD)						Indices Amode I 103.8 Aovera II 103.1				
Phase Newton																	
R_Date GU-1952	-3793	- 3652	68.2 7	- 3945	- 3640	95.4 5	-3900	- 3672	68.2 7	- 3946	- 3648	95.4 5		97.2			99. 7
R_Date GU-1951	-3762	- 3538	68.2 7	- 3793	- 3526	95.4 5	-3711	- 3536	68.2 7	- 3767	- 3527	95.4 5		105. 4			99. 8
Sequence Port Charlotte																	
Boundary Start pre-cairn activity							-3829	- 3656	68.2 7	- 4089	- 3543	95.4 5					98
Phase Pre-cairn activity																	
R_Date HAR-3487	-3945	- 3709	68.2 7	- 3981	- 3641	95.4 5	-3749	- 3640	68.2 7	- 3912	- 3536	95.4 5		87.6			99. 8
R_Date HAR-3486	-3784	- 3645	68.2 7	- 3946	- 3543	95.4 5	-3731	- 3638	68.2 7	- 3892	- 3533	95.4 5		112. 6			99. 8
R_Date HAR-2386	-3622	- 3355	68.2 7	- 3640	- 3103	95.4 5	-3646	- 3562	68.2 7	- 3711	- 3461	95.4 5		68.2			99. 9
Boundary End pre-cairn activity							-3631	- 3509	68.2 7	- 3692	- 3416	95.4 5					99. 9
Boundary Start cairn activity							-3538	- 3403	68.2 7	- 3625	- 3355	95.4 5					99. 9

Name	Unmodelled (BC/AD)						Modelled (BC/AD)						Indices Amode I 103.8 Aovera II 103.1				
Phase Cairn activity																	
R_Date HAR-2406	-3622	- 3375	68.2 7	- 3634	- 3368	95.4 5	-3501	- 3367	68.2 7	- 3574	- 3194	95.4 5		99			99. 8
R_Date HAR-2084	-3367	- 3103	68.2 7	- 3509	- 3015	95.4 5	-3511	- 3310	68.2 7	- 3524	- 3134	95.4 5		76.9			99. 7
Boundary End cairn activity							-3492	- 3257	68.2 7	- 3522	- 2946	95.4 5					98
Sequence Giant's Grave, Nereabolls																	
Boundary Start pre-cairn activity							-3736	- 3651	68.2 7	- 3873	- 3642	95.4 5					99. 2
Phase Pre cairn activity																	
R_Date OxA-40131	-3756	- 3648	68.2 7	- 3771	- 3644	95.4 5	-3686	- 3644	68.2 7	- 3748	- 3637	95.4 5		109			99. 8
R_Date OxA-40132	-3629	- 3516	68.2 7	- 3634	- 3380	95.4 5	-3630	- 3578	68.2 7	- 3635	- 3516	95.4 5		118. 3			100
R_Date OxA-40051	-3623	- 3383	68.2 7	- 3629	- 3378	95.4 5	-3626	- 3581	68.2 7	- 3632	- 3508	95.4 5		105. 8			100

Name	Unmodelled (BC/AD)						Modelled (BC/AD)						Indices Amode I 103.8 Aovera II 103.1				
Boundary End pre-cairn activity							-3601	-3501	68.2 7	-3618	-3417	95.4 5					99. 9
Boundary Start cairn activity							-3508	-3365	68.2 7	-3547	-3362	95.4 5					99. 7
Phase Cairn activity																	
R_Date OxA-40130	-3502	-3370	68.2 7	-3516	-3366	95.4 5	-3443	-3359	68.2 7	-3493	-3357	95.4 5		87.9			99. 9
R_Date OxA-40050	-3363	-3134	68.2 7	-3368	-3105	95.4 5	-3363	-3342	68.2 7	-3486	-3197	95.4 5		123. 6			99. 8
R_Date OxA-40049	-3487	-3361	68.2 7	-3496	-3349	95.4 5	-3376	-3356	68.2 7	-3492	-3347	95.4 5		107. 7			99. 9
Boundary End cairn activity							-3364	-3306	68.2 7	-3484	-3137	95.4 5					98. 8
Phase Bolsay																	
R_Date AA-21631	-3629	-3383	68.2 7	-3636	-3375	95.4 5	-3631	-3510	68.2 7	-3639	-3387	95.4 5		104			99. 9
R_Date AA-21638	-3513	-3362	68.2 7	-3626	-3132	95.4 5	-3500	-3360	68.2 7	-3534	-3141	95.4 5		103. 6			99. 9

Name	Unmodelled (BC/AD)						Modelled (BC/AD)						Indices Amode I 103.8 Aovera II 103.1					
		-	68.2	-	-	95.4		-	68.2	-	-	95.4						
R_Date AA-21634	-3331	-3027	68.27	-3346	-2935	95.45	-3328	-3026	68.27	-3346	-2933	95.45		99.6				99.8

Table 3

Output from Bayesian model for dates from Port Charlotte (prefix HAR, n=5) and Giant's Grave (prefix OxA, n=4) placed together to show pre-cairn and the earliest post-construction phases at both sites. OxCal m4.4.4 (Bronk Ramsey 2021) using IntCal2020 (Reimer et al. 2020). See Illus 29.

Name	Unmodelled (BC/AD)						Modelled (BC/AD)						Indices Amode I 84.7 Aovera II 85.4	Acomb	A	L	P	C
		from	to	%	from	to		%	from	to	%	from						
Sequence Rhinns of Islay chambered cairns																		

Name	Unmodelled (BC/AD)						Modelled (BC/AD)						Indices			
													Amode 184.7	Aovera 1185.4		
Boundary Start pre-cairn activity							-3747	- 366 1	68.2 7	- 384 7	- 364 8	95.4 5				98
Phase Pre-cairn activity																
R_Date HAR-3487	-3945	- 370 9	68.2 7	- 398 1	- 364 1	95.4 5	-3713	- 364 1	68.2 7	- 381 1	- 361 8	95.4 5		80. 9		10 0
R_Date HAR-3486	-3784	- 364 5	68.2 7	- 394 6	- 354 3	95.4 5	-3701	- 363 8	68.2 7	- 378 7	- 354 3	95.4 5		11 6		10 0
R_Date OxA-40131	-3756	- 364 8	68.2 7	- 377 1	- 364 4	95.4 5	-3692	- 364 6	68.2 7	- 375 0	- 363 9	95.4 5		11 1		10 0
R_Date OxA-40132	-3629	- 351 6	68.2 7	- 363 4	- 338 0	95.4 5	-3629	- 358 5	68.2 7	- 363 6	- 352 1	95.4 5		12 1		10 0
R_Date OxA-40051	-3623	- 338 3	68.2 7	- 362 9	- 337 8	95.4 5	-3624	- 358 7	68.2 7	- 363 1	- 351 6	95.4 5		10 7		10 0
R_Date HAR-2386	-3622	- 335 5	68.2 7	- 364 0	- 310 3	95.4 5	-3635	- 357 9	68.2 7	- 364 9	- 350 2	95.4 5		75. 8		10 0

Name	Unmodelled (BC/AD)						Modelled (BC/AD)						Indices				
Boundary End pre-cairn activity							-3606	-3517	68.27	-3618	-3475	95.45					100
Boundary Start cairn activity							-3533	-3454	68.27	-3566	-3380	95.45					100
Phase Cairn activity																	
R_Date HAR-2406	-3622	-3375	68.27	-3634	-3368	95.45	-3511	-3377	68.27	-3525	-3366	95.45					1020
R_Date OxA-40130	-3502	-3370	68.27	-3516	-3366	95.45	-3500	-3372	68.27	-3515	-3366	95.45					1040
R_Date HAR-2084	-3367	-3103	68.27	-3509	-3015	95.45	-3503	-3357	68.27	-3522	-3296	95.45					57.10
Boundary End cairn activity							-3494	-3347	68.27	-3513	-3201	95.45					97

References

- Hather, J 2000 *The Identification of the Northern European Woods: A Guide for Archaeologists and Conservators*. London: Archetype.
- Schweingruber, F H 1990 *Microscopic Wood Anatomy*, 3rd edition. Birmensdorf: Swiss Federal Institute for Forest, Snow and Landscape Research.
- Stace, C 2010 *New Flora of the British Isles*, 3rd edition. Cambridge: Cambridge University Press.