

EARLY AND TRADITIONAL CULTIVATING IMPLEMENTS IN SCOTLAND¹

by ALEXANDER FENTON, M.A., B.A., F.S.A.SCOT.

INTRODUCTION

THE study of the development of cultivating implements, which 'has been used as a key-index to the development of a land and a nation'² is now well established in this and other countries. Many of the ideas relating to the evolution of ploughs, and to association between plough type and field-shape, promulgated by E. C. Curwen and others in the 1920s, have proved inadequate, though they were widely accepted and still find a place in school and university text-books. A number of misapprehensions was corrected and the subject set firmly on its feet in 1948 by F. G. Payne in his important article, *The Plough in Ancient Britain*.³ Here, and in subsequent writings,⁴ he included a certain amount of Scottish material, since supplemented by R. B. K. Stevenson's short, but valuable *Notes on Early Agriculture in Scotland*.⁵ Later Scottish plough history has been partly dealt with by R. Jirlow and I. Whitaker in *The Plough in Scotland*,⁶ an article which was amongst the first to recognise the part played by spade-cultivation.

The publication in 1961 by the British Association for the Advancement of Science of H. C. Bowen's *Ancient Fields* has provided a study capable of stimulating and guiding further research. It concentrates, however, on the southern half of Britain, where much of the evidence for early fields is to be found, and shows that the weaknesses of the subject for Britain as a whole lie in the lack of detailed regional studies of plough types, and in the need to take into clearer account the potentialities of cultivating implements other than the plough in affecting field shape. The only regional study so far is the one by Payne on the Welsh Plough, written in Welsh.

The following notes were written with this background in mind. Besides surveying the archaeological evidence, they deal with implements used in the Highlands and Islands, and even in this geographically restricted area, the resulting picture is one of considerable regional variety. In Scotland, where, as G. G. Coulton empha-

¹ It will be obvious that these notes can in no way be regarded as definitive, and indeed, in so far as they do not touch upon the 'old Scotch' rectangular framed plough, they apply to less than half of the country. Many of the suggestions are put forward speculatively, as a basis for discussion, but at the same time an attempt has been made to present the evidence as concretely as possible. Even with this synopsis of half of the history of cultivation in Scotland, it will be seen that a great deal more material is available than has previously been realised, and much more should come to light as documents such as testamentary records, etc., are submitted to detailed scrutiny. These notes will have achieved their object if they provide an incentive to further research.

Thanks are due to many people for help with photographs, etc., as specified in the text, and also to Mr Robert Aitken for his stimulating correspondence, to Miss Audrey Henshall, and in particular to Robert Stevenson for his constructive criticism and ready willingness to discuss problems.

² Jope, E. M., *Agricultural Implements in C. Singer Hist. Technology*, Oxford (1956), II, 93.

³ *Arch. J.*, CIV (1947), 82-111.

⁴ *Yr Adrdr Gymreig*, Cardiff (1954); *The British Plough: Some Stages in its Development*, in *A.H.R.*, v (1957), 74-84.

⁵ *A.H.R.*, VIII (1960), 1-4.

⁶ *Scottish Studies*, I (1957), 71-94.

sised in his series of Rhind lectures in 1931, agriculture is basic to the history of the country 'in even greater predominance than in most other countries',¹ it is important to try to establish the different types of cultivating implements, to assess them in the light of variations in climate, soil, terrain, and social structure, and to see how these were in turn affected by changes in the cultivating implements themselves. Even in the sphere of administrative and institutional history the potentialities of the plough and its needs in man and animal power has had a marked effect, and it is no accident that in Anglo-Saxon England, for example, the plough was treated as a unit of assessment for military and church dues.² In Scotland, much legislation was aimed at keeping the plough in the ground, starting with Alexander II in 1214, and an Act of 1587 went as far as to impose the death penalty on anyone maiming plough animals and cutting ploughs and plough gear³ – misdemeanours which numerous entries in the Register of the Privy Council show to have been by no means uncommon. The type that gets into the nation's laws, however, is the 'old Scotch' plough with its large team of draught animals. The implements with which these notes are primarily concerned never acquired such status.

I. ARCHAEOLOGICAL EVIDENCE

(1) *Stone-Bronze Age*

The earliest evidence for implements of cultivation comes from Shetland, and appears to be nearly two thousand years earlier than any other evidence from Scotland. This is tantalising, since conditions in the Northern Isles are not characteristic of Scotland as a whole, and it is unsafe to generalise. However, it is reasonable to infer that though the material culture of the Northern Isles has developed regional characteristics, it is nevertheless likely to reflect some Mainland Scottish traditions, and a stone artefact in Shetland may well represent a wooden artefact elsewhere.

The evidence for cultivating implements in Shetland, and to a lesser extent Orkney, takes the form of a number of stone bars of a particular type. The majority are in cross-section like a flattened oval, and vary in length from 1 to 3 ft., the average falling between 12 and 18 in. Others are more rounded in section and more sharply pointed (fig. 1). The largest known is 3 ft. 2½ in. long and came from under 3 ft. 6 in. of peaty soil at Urafirth, Northmavine, Shetland. It is pointed at each end and both points show traces of wear at one side only.⁴ Comparatively few bars survive complete, but numerous broken off tips have been found. The sample (AC 609) from Lower Gruniquoy, Northmavine, Shetland, illustrated in *P.S.A.S.*, LXXXIX (1955-6) 395, is one of twenty-six found there, and the one (HD 1165) from the Ness of Gruting, illustrated on the same page, shows the flat, oval type. What all these bars have in common is the distinctive manner in which one side of the point

¹ Coulton, G. G., *Scottish Abbeys and Social Life*, Cambridge (1933), 134.

² e.g. Attenborough, F. L., *The Laws of the Earliest English Kings*, Cambridge (1922), II Æthelstan 16; Edward and Guthrum 6 § 3, I Æthelstan 4; A. J. Robertson, *The Laws of the Kings of England from Edmund to Henry I*, Cambridge (1925), II Edgar 1 § 1, VII Æthelred 7, I Canute 8 § 1-2, I Edmund 2, V Æthelred 11 § 1, VI Æthelred 16, VIII Æthelred 12.

³ See Cochran-Patrick, R. W., *Medieval Scotland*, Glasgow (1892), 20-21, 23-25.

⁴ *P.S.A.S.*, LXXXVI (1951-2), 206, Pl. XLIII, 4. I am indebted to Peter Moar, F.S.A.Scot., for additional details.

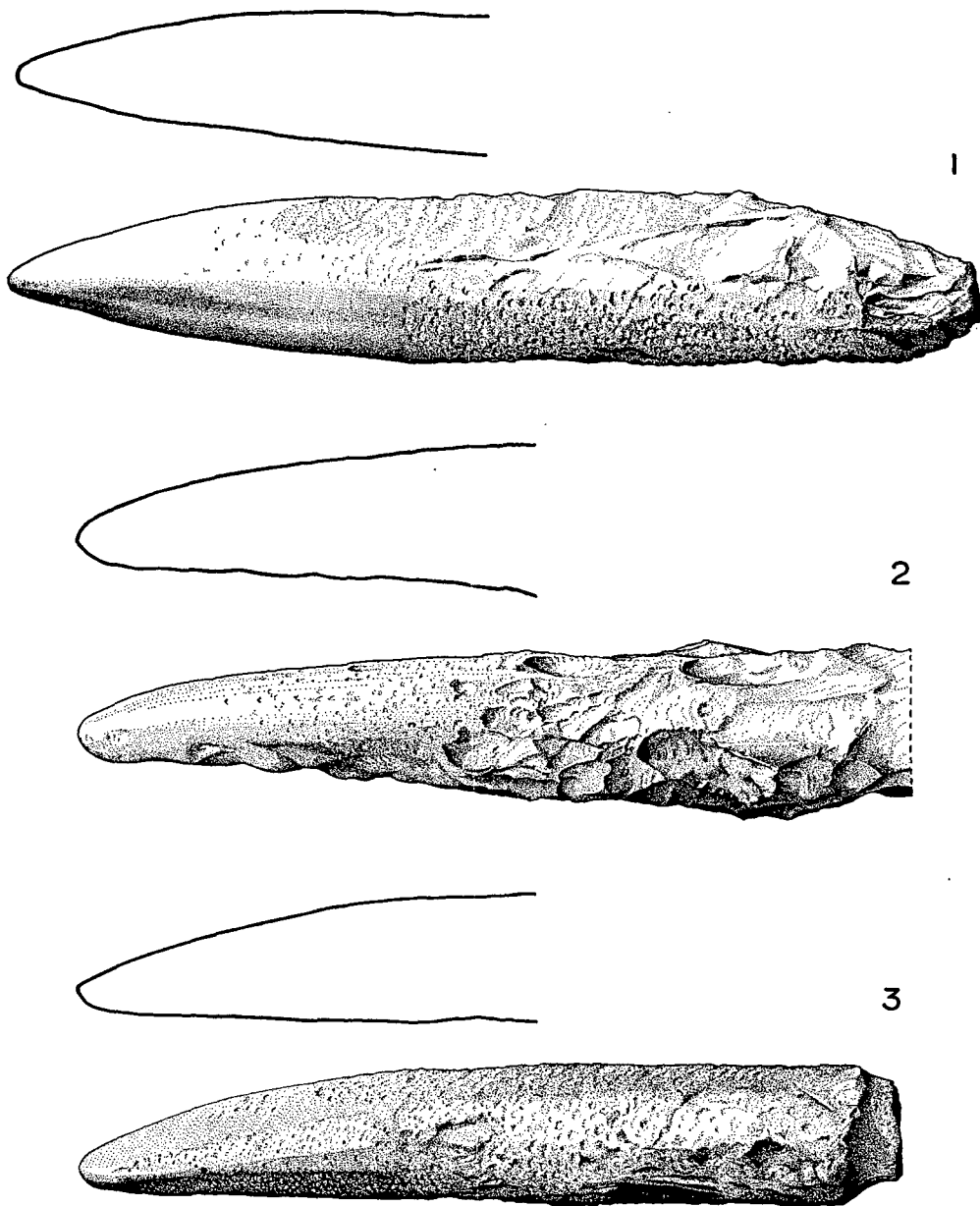

FIG. 1. Bar shares of stone: 1. From Shetland, oval cross-section, 16 by 3.6 in. (AC 607); 2. From Shetland, rounded cross-section, 21 by 2½ in. (AC 17); 3. From Orkney, oval cross-section, collar at back, 13.3 by 3.3 in. (AC 648)

has been worn smooth by use. The area of wear extends about $2\frac{1}{2}$ to 4 in. back from the tip. The way in which the wear is confined implies that the bars were fitted into a wooden frame, and is one of the clues to their possible use. R. B. K. Stevenson was the first to suggest in 1956¹ that they might have acted as shares for a primitive type of plough, an *ard*, of which numerous wooden examples and parts have been found in peat bogs in Denmark and elsewhere on the Continent, and two in SW. Scotland. If this is so, the bars were probably mounted in a mortise in the end of the plough-beam in the same manner as wooden shares are mounted in the composite variety known as a *bow-ard* (fig. 2).

An interesting parallel is offered by the iron sock bars patented by the plough-making firm of Sellars of Huntly in the early 1900s for horse-drawn ploughs, now widely used on tractor ploughs. These are ribbed or notched for a better grip on the

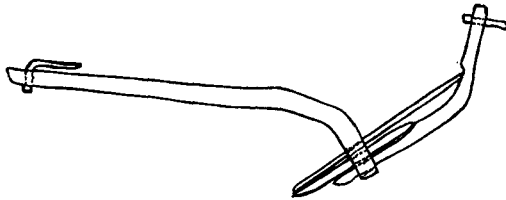

FIG. 2. The Donneruplund bow-ard, after Glob. The mortise in the beam holds, from left to right, the fore-share, share, and combined plough-head and stilt

frame in which they lie, just as the stone bars are flaked or pecked. In use the tips wear to one side and have then to be turned so that the sharpest part of the tip is always in closest contact with the land. The stone-bars also have tips worn to one side, and at least one example (AC 607) in the National Museum, from Unst, Shetland, has been similarly turned. The iron sock bars lie at a shallow angle of about 20° - 25° , which would agree fairly well with the angle of the share in the mortise of a beam such as that from Lochmaben (Pl. XLIV, 1).

There is in addition to this an important parallel of Roman date, in the form of a number of iron bars from Silchester in Berkshire, and Great Chesterford in Essex. One was illustrated by R. C. Neville as early as 1856,² and another reproduced in diagrammatic outline by F. A. Aberg was wrongly described by him as a Romano-British coulter.³ In both, the bars have been worn at each end in the same way as some of the stone bars from Shetland, and can in no way be regarded as coulters. They range in length from 2 to 3 ft., and are $1\frac{1}{4}$ by 1 in. in section, agreeing very closely with the dimensions of modern bar shares. The character of the wear on the tips is also similar to that on both modern bar shares and prehistoric stone shares (Pl. XLIV, 2-3). The bars in both hoards date from the fourth century A.D. William Manning of University College, Cardiff has come independently to the conclusion that these are bar shares used on ards. His views have been published in the *Journal*

¹ P.S.A.S., LXXXIX (1955-6), 395-6.

² Arch. J., XIII (1856), 4 and Pl. 2, 17.

³ The Early Plough in Europe in Gwerin (1957), 1, 179, fig. 6, 12.

of *Roman Studies*, LIV (1964), 60. Presumably these stone and iron bar shares occupied the same position in the mortise of the ard beam as the wooden foreshare of, for example, the Donneruplund ard¹ (fig. 2). Their function would have been to take the brunt of the wear, and to protect an underlying arrow-shaped share of wood, or more likely to act as the share itself.² Tanged iron shares like those from Hunsbury Hill fort, Northampton, and from Box, Wiltshire,³ can then be regarded as two in one versions of the same arrangement. Shares in the form of a pointed oval shoe, like that from Blackburn Mill (fig. 4.1), the alleged Viking share in Dunrobin Castle Museum⁴ (fig. 4:9 and n. 2), various shares from Irish sources,⁵ and the shares of existing single-stilted ploughs from Orkney (fig. 12) provide an answer to the problem of preventing wear by a protective cover rather than by a replacement in iron or stone.

Additional evidence for the cultivation of crops in the Northern Isles takes the form of grain impressions on pottery, and of field systems. The impress of a grain of naked barley, *Hordeum distichum*, came from a chambered cairn at the Calf of Eday, and one of hulled barley, *Hordeum hexastichum*, from the cairn at Unstan, both in Orkney.⁶ To this, but perhaps somewhat later in time, can be added a find of 28 lb. of carbonised barley hermetically sealed under a mass of peat ash at a house site reflecting a retarded neolithic tradition at Gruting, Shetland,⁷ with a broken dish quern lying alongside the pile. Saddle querns, trough querns, and grain rubbers came from other house sites of cognate type.

Around these houses, which are often situated 'in places where the moorland seems to have been uninhabited ever since, except for sporadic iron age squatting'⁸ there are stone clearance heaps of the kind still made by Shetland crofters and called by them *rönies*, a word of Norse etymology, and systems of fields whose occurrence has been listed by Calder.⁹ One group of five or six at the Scord of Brouster in Walls (fig. 5:1) extends to about 2 $\frac{3}{4}$ acres, which is comparable to the average arable acreage of present-day crofts even on such a fertile island as Fetlar, emphasising that the arable potential of Shetland has always been small. The fields are curvilinear in outline, and measure 60 to 260 ft. in their longest dimensions. Their boundaries are marked by walls of denuded and overgrown drystone dyking. The clearance heaps, which may be up to 20 ft. across and 2 ft. high, occur both inside and outside the fields, implying that the fields as now demarcated are superimposed on previously cultivated land. Unfortunately, the uncertain dating of the pottery from these oval house sites makes precise dating of the bar shares and field systems difficult. In the

¹ See Bowen, H. C., *Ancient Fields* (London 1961), 8, for a diagram of the structural features of this ard.

² See Glob, P. V., *Ard og Plov* (Aarhus 1951), 58-71; van der Poel, J. M. G., *De Landbouw in het verste Verleden in Berichten van de Rijksdienst voor het oudheidkundig Bodemonderzoek*, x-xi (1960-1), 158-9.

³ Payne, F. G., in *Arch. J.*, civ (1947), 93, and fig. 1.8, 9, and 17.

⁴ Shetelig, H., *Viking Antiquities in Great Britain and Ireland*, Oslo (1940), II, 161.

⁵ Ó Ríordáin, S., and Foy, J. B., *Leacanabaile Stone Fort in Jnl. Cork Hist. and Arch. Soc.*, XLVI (1941), 92, and facing p. 94; Duignan, M., *Irish Agriculture in Early Historic Times in J.R.S.A.I.*, LXXIV (1944), 137; Wood-Martin, W. G., *The Lake Dwellings of Ireland*, Dublin (1886), 141 and Pl. XXXIII, 8.

⁶ Jessen, K. and Helbæk, H., *Cereals in Great Britain and Ireland in Prehistoric and Early Historic Times in Kong. Danske Videns. Selskab* (Biol. Skrift. III) (1949), 18.

⁷ Calder, C. S. T., *Stone Age House Sites in Shetland in P.S.A.S.*, LXXXIX (1955-6), 353-4.

⁸ Stevenson, R. B. K., *Notes on Early Agriculture in Scotland in A.H.R.*, VIII (1960), 1.

⁹ Calder, C. S. T., op. cit., 363 ff.

case of Jarlshof, better dating is possible, since traces were found of a Late Bronze Age field system bounded by walls of loosely built stones surviving to a height of 3 ft. 6 in. These were covered by 5 ft. of windblown sand, and a later field system of Iron Age date was established on top.¹ Jarlshof, therefore, proves the existence of field systems in the Late Bronze Age, and the oval houses, though maintaining a retarded neolithic cultural tradition into what was the Bronze Age in Britain, may be associated with fields of earlier date, probably contemporary with, or even slightly later than the criss-cross ploughshare marks of *c.* 1600 B.C., found in recent years in Bronze Age fields at Gwithian in Cornwall.²

(2) *Iron Age: evidence of wooden parts*

Two finds provide evidence for ards in SW. Scotland about the first-second century A.D. One is a heavy beam 8 ft. 1½ in. long that came from a peat-bog at Lochmaben, Dumfriesshire, in 1870, now preserved in the Dumfries Burgh Museum (Pl. XLIV, 1). The rear end, 5 by 3.25 in. in section, has a mortise at the lower end, measuring 4.25 by 1.6 in. through which would have gone, on the analogy of continental finds of bow-ards of Late Bronze-Early Iron Age date, a wooden share and fore share, and a plough-head and stilt like the one from Milton Loch Crannog (fig. 3). There is a further aperture measuring 2.3 by 0.9 in. in the fore-part of the beam, to hold the yoke attachment. Though by no means heavy, such an implement would certainly have done more than merely scratch the ground surface.

The combined plough-head and stilt from Milton Loch Crannog³ measures 4 ft. 2.5 in. overall, the arrow shaped head being 11.6 in. long by 5.25 in. wide (fig. 3). There are two raised ridges and a groove on the upper surface to grip the share in position, a feature also known on continental ards. There is a backwards curving hand-grip cut from the solid, in appearance like the wood or horn handles of some of the peat-spades still found in Galloway.

The excavator of the crannog, Mrs C. M. Piggott, has suggested on the analogy of continental finds⁴ that this may have been a ritual deposit, but though it underlay the floor of the crannog, its position had no special significance. It had been broken when deposited, and may well have been thrown in as filling. Since finds in the crannog can be dated to the second century A.D., the plough-head and stilt must antedate them and indeed it must antedate the crannog itself. There is no means of dating the Lochmaben beam, but it is unlikely to be far separated in time from the Milton Loch Crannog ard.

(3) *Iron age: evidence of iron parts*

The arrival, some time in the first century B.C., of what seems to have been a refugee movement from the south of Britain, and of the Romans shortly after, added a new element to the history of cultivation in Scotland – the use of iron ploughshares. The movement came from areas where grain-growing was carried on in fields tilled

¹ Hamilton, J. R. C., *Jarlshof* (Edinburgh 1956), 84.

² See Megaw, J. V. S., Thomas, A. C. and Wailes, B., *The Bronze Age Settlement at Gwithian, Cornwall* in *Proc. West Cornwall Field Club*, 11 (1960-1), 200-15.

³ Piggott, Mrs C. M., *Milton Loch Crannog I* in *P.S.A.S.*, LXXXVII (1952-3), 143-4, Pl. XVI.

⁴ Cf. Glob, *op. cit.*, 102-8.

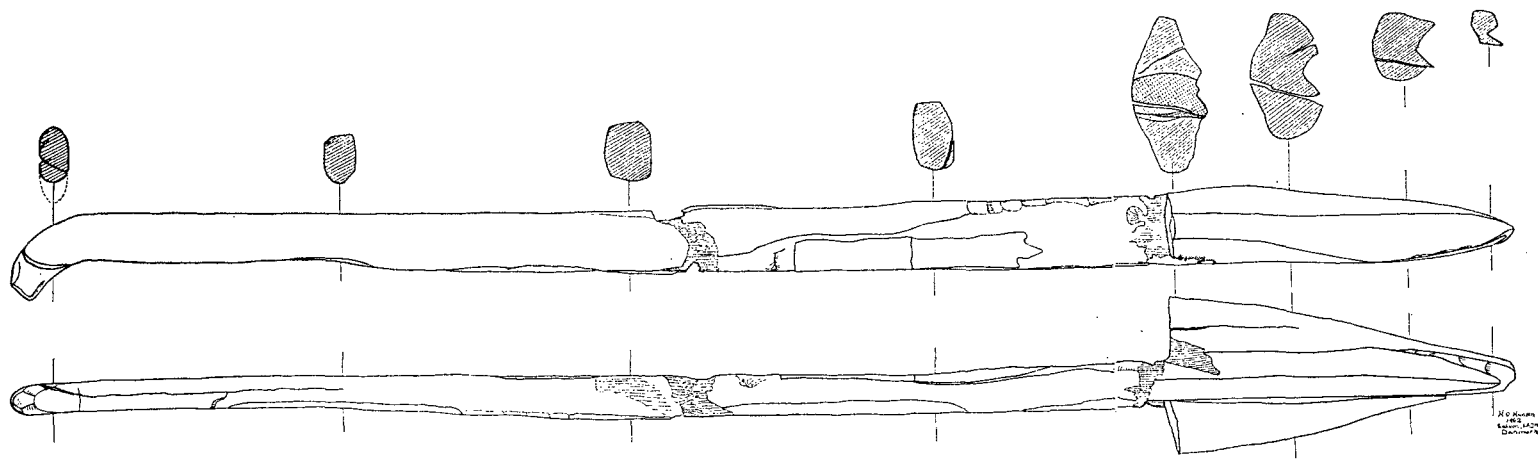

FIG. 3. The Milton Loch Crannog plough-head and stilt, at present undergoing treatment in the National Museum of Denmark, where Professor A. Steensberg kindly arranged for this diagram to be made

by a traction plough, and where comparatively sophisticated methods of grain storage were employed.¹ Finds of iron shares and coulter in these areas demonstrate conclusively the use of ploughs with iron fittings from the time of the Iron Age A settlements onwards. The earlier shares illustrated by Payne are either tanged, or very long and narrow with bluntly pointed or rounded tips, and sides running in a straight line from the tip to the back of the socket flange, without shouldering. Payne suggests that the tanged shares must have belonged to ploughs like the bow-ard from Døstrup in Jutland, and that the socketed spear-point type belonged to a plough with a horizontal share beam.

By comparison, the Iron Age C and Romano-British shares are much broader, and almost rectangular in appearance. One of the Bigbury examples swells out at the face, symmetrically, so that it is wider there than at the socket, like three Dutch ones illustrated by van der Poel.² The second Bigbury share may be similar, but is too worn for certainty. The 'broad' share from Silchester is as narrow as the earlier spear-point shares.

None of the features of these shares is reproduced by the Scottish finds, which in themselves are far from forming a homogeneous group. Four of them have been considered by Payne in his group of broad shares (Traprain Law, Eckford, Falla Farm, Blackburn Mill). To these can be added another one from Traprain Law, not hitherto recognised as belonging to the same group.

The Scottish material falls into three divisions:

(a) Blackburn Mill, DW 113 (fig. 4:1). This is in the form of a wedge-shaped shoe, with a rounded point worn more at the left or landside than at the right, and flanged along its full length. It has a single hole near the back at the left side, perhaps a nail hole. It corresponds in position to nail holes in the somewhat similarly shaped though much slighter shares on some of the single stilted Orkney ploughs. The greater amount of wear on the left side of the point must imply that it was used on a plough that turned a furrow slice consistently to the right, and it may be significant that the left flange is noticeably flat and straight.

This share came from a metalwork hoard from Blackburn Mill, Cockburnspath, Berwickshire. In the same hoard was the iron blade of an undoubted peat-spade (fig. 4:7) with its characteristic feather (DW 108), and another blade (DW 109) which, though much corroded so that there is no trace of a feather, is similar in general proportions and in thickness, and may be accepted as a second peat spade blade (fig. 4:6).³ A slanting line across the face of each at roughly the same point may represent the mark left by the doubling and beating of the blade during forging. Professor Piggott comments that the presence of peat spade blades in a Romano-British context is surprising and that intrusion may be suspected, but as Stevenson points out, they do not in any way stand out from the rest of the metalwork and their contemporaneity is probable.⁴ As with some present day peat-spades,⁵ the socket is narrower

¹ Piggott, S., in I. Richmond, *Roman and Native in North Britain* (1958), 3-4.

² Van der Poel, *op. cit.*, 162.

³ Piggott, S., *Three Metal-Work Hoards of the Roman Period in P.S.A.S.*, LXXXVII (1952-3), 47.

⁴ Stevenson, R. B. K., *op. cit.*, 3 (footnote).

⁵ Crawford, I., *Examples of the Peat Knife in Antiquity in Scottish Studies*, VII (1963), Pl. II, fig. 2.

than the blade. Modern peat spades have a right angled shoulder only at the side opposite the feather. The Blackburn Mill blade, however, has a shoulder at each side. In addition, it has a marked sheer to the right so that its angle brings the feather almost directly under a line drawn down the side of the socket, and projects the bottom right corner of the blade correspondingly outwards. This hoard, therefore, provides evidence for both ploughing and peat-cutting.

(b) The blades from Eckford, DWA 9 (fig. 4:4) and Falla Farm EQ 538 (fig. 4:5)¹ are broader than any of the English finds, that from Eckford being the widest yet found in Britain (Table I, and see Payne, *op. cit.*, 110-11). Though both are broad and flat, the Falla Farm one is very much more solid, though this may simply be due to a difference in the degree of corrosion. Nevertheless the general appearance of the two when examined side by side suggests that the thinness of the one and the sturdiness of the other were original features. Both blades have a forward bend, particularly marked in the one from Eckford. Another shared feature is the sheer of the blades to the right, matching the sheer of the Blackburn Mill peat spade blades. It cannot be ascertained, however, if the Eckford and Falla Farm blades were shouldered in the same way.

(c) The Traprain Law blade, GVM 479 (fig. 4:2) discussed by Payne, is the narrowest of the Scottish group, with a proportionally longer socket. It is much corroded, so that its original shape cannot be certainly established, but the blade has smoothly curving shoulders at each side forming an angle of about 150° with the sides of the socket. In construction it is rather slender.²

(d) In the second Traprain Law blade, GVM 480 (fig. 4:3), the under surface forms a straight line with the lower edges of the socket flanges (the twist seen in the section has been caused when the missing half was wrenched off), and the upper surface lies at an angle to the upper side of the socket, which swells up gradually to a maximum height of 1.25 in. In the other examples, on the other hand, with the exception of the Blackburn Mill share, but including most of the southern English ones, it is the upper surfaces of the blades and sockets that form a straight line, the socket flanges protruding below. Since a flat undersurface and a gradually swelling neck are features of present day ploughshares, these points are likely to be of some diagnostic importance, and taken in conjunction with the sturdy nature of the metal-work, suggest that GVM 480 must be regarded as a ploughshare. It differs from the Blackburn Mill share, however, in having a shoulder at the right hand side, and the appearance of the remaining part tends to suggest that it was of symmetrical construction and possibly shouldered at the left side as well. Although previous writers have described this share as a 'hoe' and even as a 'very large socketed sickle which has been badly made',³ there is no doubt that rather more than half the width of the socket is missing, since the swelling at the neck is still rising from left to right (seen from the front) at the break. On this basis, a reconstruction indicates a share with a socket comparable in size to that of the Blackburn Mill share. The apparently

¹ Gunn, P. G., in *Trans. Bwk. Nat. Club.*, xxvii (1929-31), 105; Steer, K. A., in *P.S.A.S.*, LXXXI (1946-8), 184.

² Cree, J. E., *Account of the Excavations on Traprain Law in P.S.A.S.*, LVIII (1923-4), 255, fig. 11, 1.

³ Cree, J. E. and Curle, A. O., *Excavations on Traprain Law in P.S.A.S.*, LVI (1921-2), 235-6; Burley, E., *Metal-Work from Traprain Law in P.S.A.S.*, LXXXIX (1955-6), 205, 212.

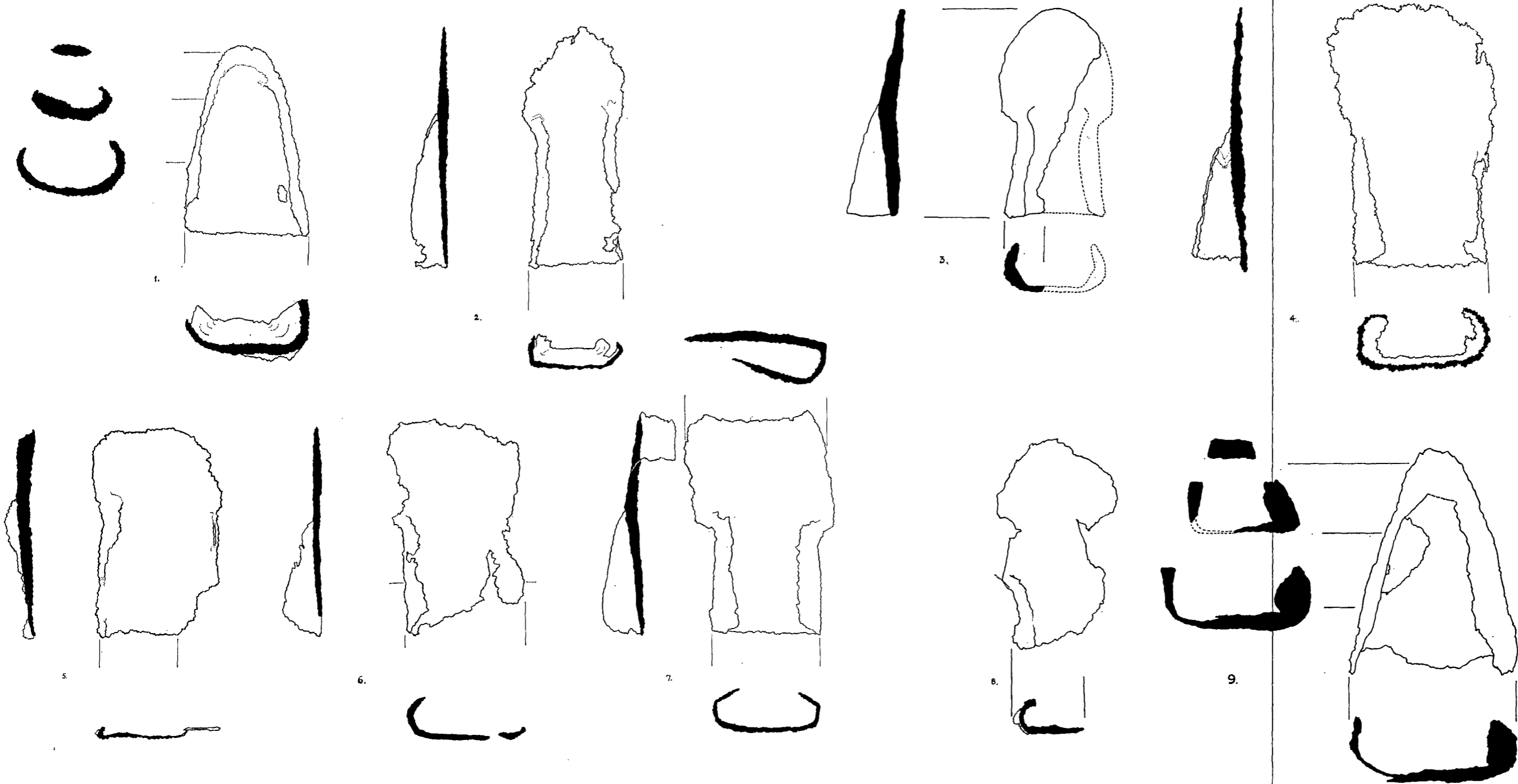

FIG. 4. 1-9. Iron blades and shares. See Table I

¹ The blade or share from South Uist (fig. 4:8) comes from a wheelhouse, Site 10, excavated by Dr Horace Fairhurst for the Ministry of Public Building and Works. It is too fragmentary for its original dimensions to be accurately established, but the curvature and shouldering of the remaining socket flange, combined with the generally triangular appearance of the blade, are reminiscent of the undated and unprovenanced Irish blades or shares illustrated as Nos. 1 and 2 by Duignan in *J.R.S.A.I.*, LXXIV (1944), 137. None of the SE. Scottish blades or shares has the same sort of incurving socket flange and the Irish analogy, if valid, suggests that the South Uist find is of a different school and possibly much later. Its condition does not permit much more to be said meantime and its approximate dating must wait until the other finds from the site have been analysed. I am indebted to Dr Fairhurst for bringing it to my attention, and to the Ministry of Public Building and Works for allowing me to examine and illustrate it.

² The iron share illustrated in fig. 4:9 is described in Shetelig's *Viking Antiquities in Great Britain and Ireland* (Oslo 1940), 162, as an 'iron plough' of the Viking period, but a little larger and wider than the usual ploughshares of that time. Has a wide opening for the insertion of the wooden part of the plough. Length about 18 cm., greatest width 12 cm. Badly rust eaten (fig. 77 - on page 161). Found in September 1880 with a *stone vessel* (steatite vessel) at Swardale near Bonar Bridge, Sutherland.³

Shetelig's claim that it is Viking may be too confident, since steatite vessels need not be confined to Viking contexts. The share, too, is wider than shares of known Viking date. According to Jan Petersen, *Vikingetidens Redskaber*, Oslo 1951, 176-7, the average width of Viking shares is 6.5-9 cm. The widest one known to him is 10.2 cm.

In addition, the majority of Viking shares have flanged sockets and flat blades, comparatively few being in the form of a shoe flanged almost up to the point. There is, for example, only one in the collection of the Historisk Museum in Oslo (No. 21386, from Nyhagen under Nedre Stabu, Opland Fylke; kindly shown to me by Dr Sjøvold), measuring 5 by 3 in. (12.5 by 7.5 cm.).

The comparable Irish shares, on the other hand, are equal in size (cf. the one from Randalstown crannog in Co. Antrim) or larger. They range in width from 4 to about 5½ in. (10-13.75 cm.). It therefore appears that comparisons should be looked for in Ireland rather than in Scandinavia, and in view of the similar second century Blackburn Mill share, the possibility has to be envisaged that we are here dealing with a native type that antedated the Viking invasions, and survived, on the Irish evidence, at least into the tenth century.

triangular form of the share would mean that it belonged to an ard rather than to a plough. It came from the rather confused third level of the 1921 excavations on Traprain Law, and is likely to date from the third century A.D.

The Scottish group of blades and shares, therefore, shows considerable diversity. The time range, first-third century, makes it broadly contemporary with the English group, and so it is the more surprising that their character should be so different. The Blackburn Mill share is not paralleled in England, but rather by shares of later date from Viking or alleged Viking contexts in Scotland (fig. 4: 9 and n. 2) and Ireland. The Traprain Law share (GVM 479) is also unparalleled. The Eckford blade is broader than any from England, and, like the undated Falla Farm blade, has a marked sheer to one side and a slight upward tilt in the blade not found in English blades, but repeated on the Blackburn Mill peat spade blades, and on the blades of peat and delving spades of the present day. On the whole, least strain is put on the evidence if these two blades are taken to represent a peat or turf spade blade (Eckford) and a delving spade blade (Falla Farm), since the latter is much more stoutly built.

Spade cultivation at this period is by no means impossible. Already in the Bronze Age spades with triangular shaped heads were being used along with ploughs in the fields at Gwithian in Cornwall.¹ The Romano-British settlement at Cottenham in Cambridgeshire has around it groups of what are described by Professor Clark as 'lazy beds',² and similarly narrow ridges of c. 600 B.C. have been found in

TABLE I
EARLY IRON BLADES AND SHARES

Source	Suggested Function	Length Overall	Socket Width (Internal)	Width of Blade	Length of Blade
1. Blackburn Mill DW 113	Ploughshare	+6.1 in	3.7 in.	—	—
2. Traprain Law GVM 479	Peat or turf spade	+7.25 in.	2.75 in.	+3.25 in.	+2.75 in.
3. Traprain Law GVM 480	Ploughshare	6.25 in.	—	+2.75 in.	3.4 in.
4. Eckford DWA 9	Peat or turf spade	+7.75 in.	3.6 in.	+5.0 in.	+3.8 in.
5. Falla Farm EQ538	Delving spade	+6.7 in.	c. 3.6 in.	+4.1 in.	+2.25 in.
6. Blackburn Mill DW109	Peat spade	+6.9 in.	c. 3.2 in.	+4.25 in.	+3.0 in.
7. Blackburn Mill DW 108	Peat spade	7.0 in.	3.1 in.	4.4 in.	3.5 in.
8. Drimore, South Uist	?	+6.25 in.	—	+3.6 in.	+3.75 in.
9. Dunrobin	Ploughshare	7.0 in.	4.2 in.	—	—

Note: the + sign indicates that corrosion or wear has reduced the original dimensions.

¹ Megaw, Thomas and Wailes, *op. cit.*, page 9 of the article.

² Clarke, J. G. D., *Excavations on the Cambridgeshire Car Dyke in Ant. J.*, xxix (1949), 145-53.

SCORD OF BROUSTER

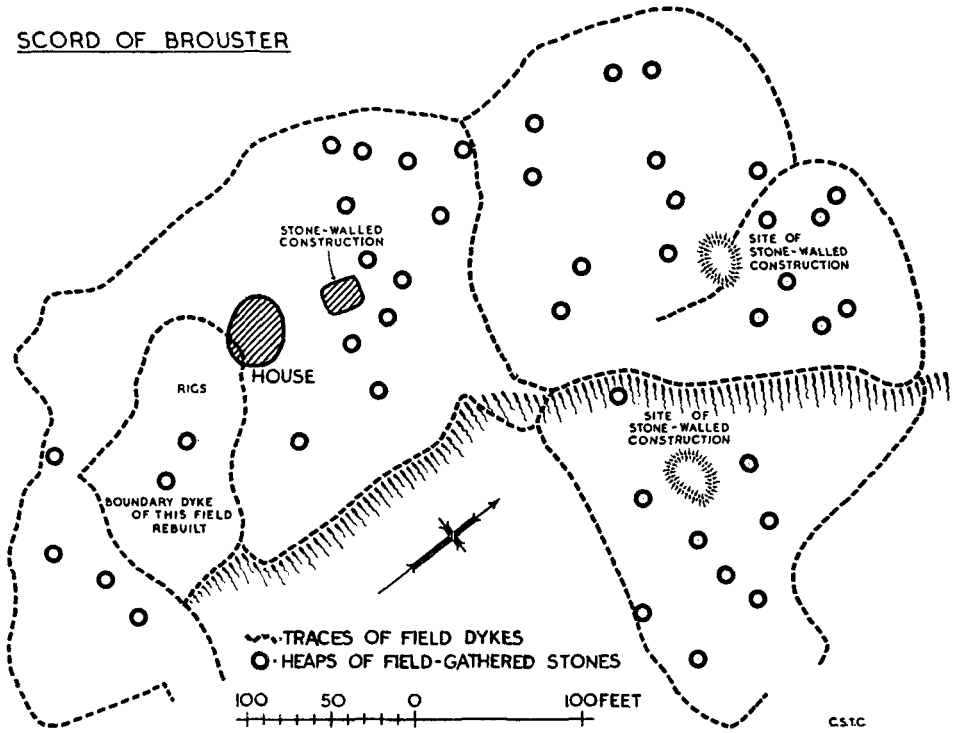

FIG. 5. 1

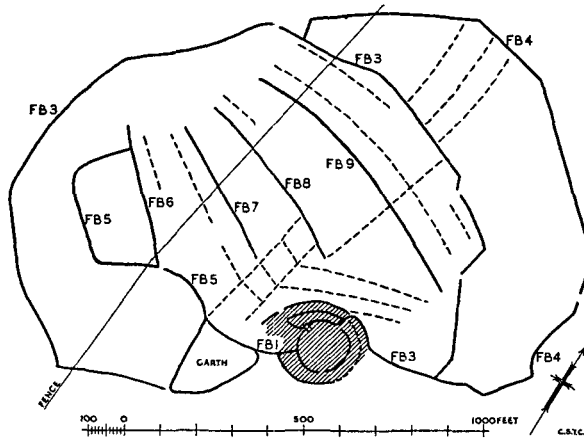

FIG. 5. 2

FIG. 5: 1-3. Field systems in Scotland: 1. The Scord of Brouster, Shetland, from *P.S.A.S.*, LXXXIX (1955-6), 371; 2. Tamshiel Rig, Roxburghshire, from the *R.C.A.M. Roxburghshire Inventory*, 11, 427, by permission of the Controller of H.M. Stationery Office; 3. Glenrath, Peeblesshire, from *P.S.A.S.*, LXXV (1940-1), 110.

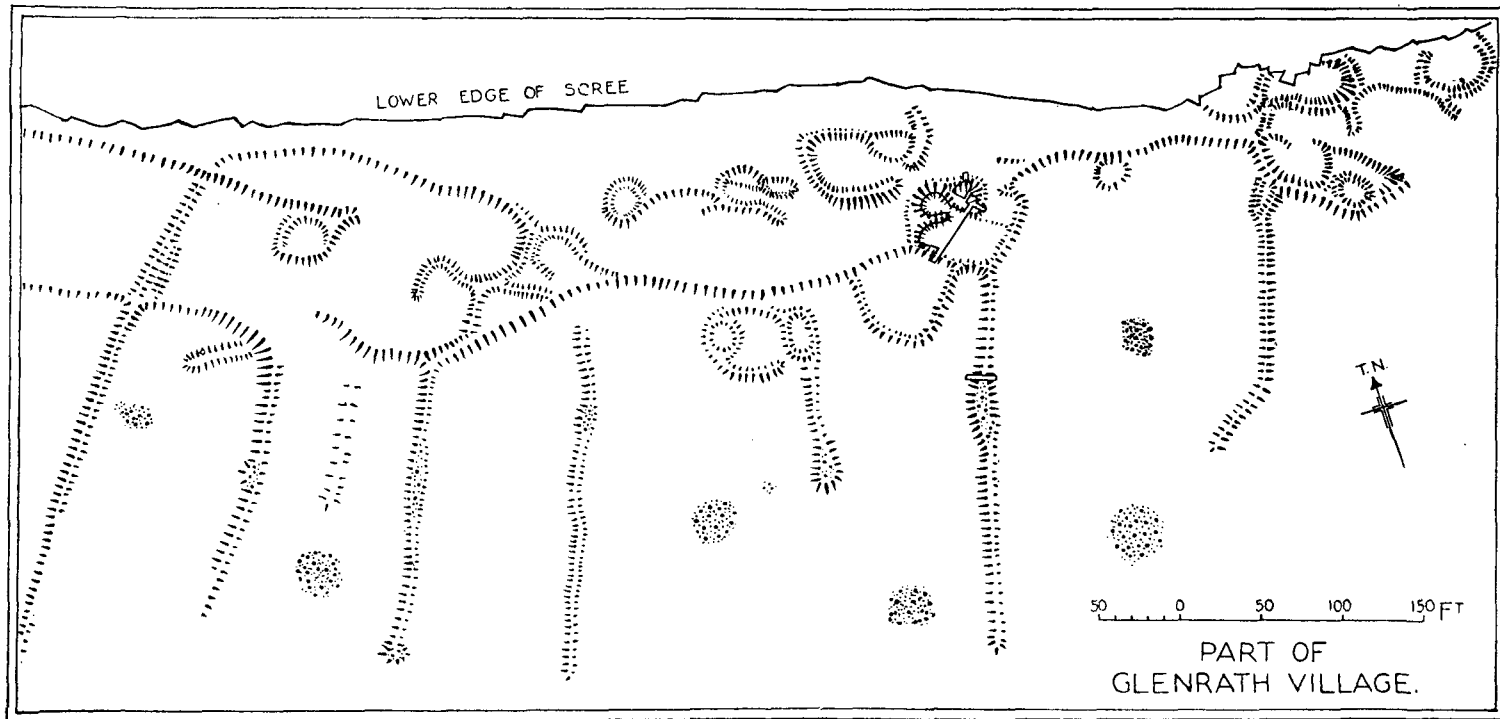

FIG. 5:3

Holland, under a burial mound of the Migration period in Norway, and on a site of Viking Age in Denmark.¹ These were presumably tilled with the spade in the same way as the Hebridean lazy beds at the present day. It is surely not without significance that the spade characteristic of lazy bed cultivation in the Highlands, the straight spade or *cas dhireach* (fig. 16: 1-2), has a blade with a slight forward bend and sometimes a sheer to the right in the manner of the early Scottish blades, though these are in general rather wider. A survey of socket widths of implements in the National Museum, showed that delving spades varied between 2.3 and 2.9 in., peat spades about 2.1 to 2.2 in. (except for the very wide 3.75 in. Galloway type), turf or flachter spades 2.5 to 2.8 in., and *cas chroms* 2.9 to 3.6 in. From this it seems that the early blades match the broader group of present day blades, but on the other hand there is the fact that a peat spade blade of the period is 3.2 in. wide, and other blades in the group match this very closely. Modern refinements in shaft sizes were probably not to be expected in the first-second century A.D.

It would appear, therefore, that cultivation by both plough and spade is likely to have been carried on in SE. Scotland in Romano-British times. The evidence is reinforced by the existence of a number of field systems in the area associated with Early Iron Age hill forts and settlements (fig. 5: 2-3). They have been noted in Roxburghshire at Crock Cleuch, Blakebillend, Grubbit Law, Pudding Law and Tamshiel Rig,² and in Peeblesshire at Glenrath village in the Manor Valley,³ a site tentatively ascribed by Stevenson to the Iron Age. The most noteworthy of these is Tamshiel Rig, where they cover 31½ acres. Both here, and at Glenrath, where the fields are associated with clearance heaps, the boundaries form groups of long, geometrical looking fields, very much more sophisticated than those at the Scord of Brouster in Shetland. Their length and breadth are suggestive rather of the plough than the spade, and possibly of the plough rather than the ard. They may mark, as Professor Piggott has suggested,⁴ the stimulus to improved farming and increased grain production that the presence of Roman legions gave, and it is tempting to link the iron blades with this expansion. Indeed, the labour involved in breaking in land for cultivation on the hillsides where these field systems are found would be considerable without the use of iron bladed implements.

(4) *Early Historical Times: plough pebbles*

The last kind of archaeological evidence for early ploughs takes the form of a number of small pebbles of quartzite, or, more rarely, flint. They are worn at one side to a convex face (fig. 6). Examples in the National Museum come from the site of the Roman fort at Newstead, Roxburghshire, from fields on a farm near Hawick, and at Ancrum Mains, and Dryburgh Mains, Orchardfield, all in the same county; from Inveresk, Midlothian; from St Blane's, Bute (the only one from the W.); and

¹ Steensberg, A., *Plough and Field Shape in Selected Papers of the Fifth International Congress of Anthrop. and Ethnol. Sciences*, Philadelphia (1956).

² *R.C.A.M.S. Rxb. Inventory* (Edinburgh 1956), I, 21; II, 427, etc.

³ Stevenson, R. B. K., *A Primitive Village in the Parish of Manor in P.S.A.S.*, LXXV (1940-1), 108-14.

⁴ Piggott, S., in Richmond, op. cit., 25.

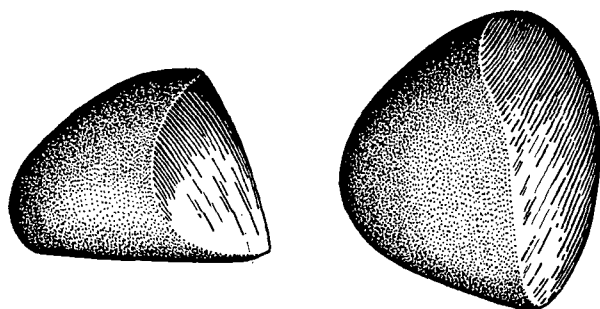
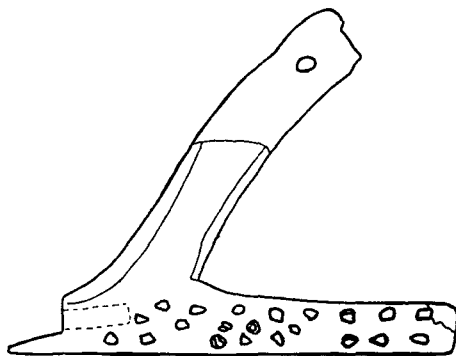

FIG. 6. Characteristic plough pebbles, with striations running across the convex face

from Jarlshof, Shetland. The majority are from Newstead and were found by chance in the course of gleaning the fields for relics of the Roman occupation.

At first the pebbles were described as 'polishers' or 'burnishers', and six of a collection of twenty-three were illustrated as such by J. M. Corrie¹ in 1914. It was not until the publication in 1936 of a description of a wooden plough-sole from Tømmerby in Denmark, studded with similarly worn pebbles that their true purpose and the true cause of the wear was recognised.² Pollen analysis of remains of peat in the plough-sole produced a date on the basis of which the sole was assigned to the pre-Roman Iron Age in Denmark. Some scepticism was felt about this dating,³ and in 1961 a fresh examination by a process of lignite extraction of the Tømmerby sole and two others from Andbjerg and Villersø led to a revised dating of A.D. 1500-1600. The plough-soles, in fact, were medieval. Indeed, wooden ploughs using pebbles as an anti-wear device were in use in Jutland as recently as the beginning of



ANDBJERG PLOUGH AFTER GLOB

FIG. 7. The pebble-studded plough-sole of the Andbjerg plough

¹ Corrie, J. M., in *P.S.A.S.*, XLVIII (1913-14), 338-41.

² Steensberg, A., *En Muldfjælsplov fra Førrømersk Jernalder* in *Aarbøger for Nordisk Oldkyndighed*, Copenhagen (1936), 130-44.

³ Glob, *op. cit.*, 76, 122.

the nineteenth century,¹ and, in the Auvergne district of France about the same period, the old farmers were said to have 'garnished' their plough-soles with pebbles, pointed at one side, and made expressly for this purpose and sold commercially. Holes were made in the sole and the pebbles knocked in with a hammer. Eight examples of pebbles from France have been illustrated by Étienne Patte.²

The age of these plough-pebbles is not precisely known, but the Danish plough-soles are late medieval, and one of the two pebbles from Jarlshof was found in the filling of a Viking outhouse (Outhouse 1 G, room 2) of twelfth or thirteenth century date.³ The outhouse was used for some time, and seems to have been ruinous by Phase VII of the occupation (thirteenth-fourteenth century) when it was used for dumping ashes and rubbish. It is not known at what level the pebble was found, nor did the filling contain any finds of significance for dating. All that can be said is that the pebble is likely to be earlier than the fourteenth century.

It is probable that ploughs with pebble-studded soles reached this country from Scandinavia. The occurrence of pebbles in Midlothian and Roxburghshire must be explained by the fact that they have also been found across the border, particularly in E. Yorkshire and N. Lincolnshire, an area of Viking settlement from which the plough-type represented by the pebbles probably spread by a process of peaceful diffusion. Eight English pebbles have been illustrated by C. W. Phillips, who notes that 'it may not be without significance that the present distribution of the objects is confined to regions of vigorous Scandinavian occupation'.⁴ At the same time, the French evidence shows they are not confined to such areas and future finds may fill out their present distribution in Scotland, but possibly not very much.

The majority of the pebbles have a convexly worn face *across* which parallel striations run. Occasionally examples occur with wear on two faces, as on one of the Jarlshof pebbles (HSA 774) and on two from Newstead.⁵ These must have fallen out in the course of ploughing, and have been picked up and re-used. There are also a few from Newstead with a flat, or only slightly curved face, highly polished, and with very light striations running with, not across, the curve. It is a moot point whether this kind of face could have been produced if a pebble had been set far into a plough-sole and protected behind a knot or hard part of the wood, or whether these are something different altogether. At any rate, the fact remains that the presence of plough pebbles does suggest the use in Scotland of large ploughs with mould boards some time in the early medieval period.

The archaeological evidence, therefore, shows that cultivation by the plough was going on in Shetland and Orkney with instruments of the ard type furnished with bar shares of stone from at least Bronze Age times. Presumably ards with wooden shares were at work elsewhere in Scotland, like the two Iron Age specimens from SW. Scotland. The iron blades and shares of the SE. imply the possible use of an

¹ Steensberg, *op. cit.*, 143.

² Patte, É., *Les 'Galets-Clous' de la Gatine des Deux-Sevres in Gallia*, ix (1952), 56-59.

³ Curle, J., in *P.S.A.S.*, LXX (1935-6), 265-6, and fig. 15, 1; Hamilton, J. R. C., *op. cit.*, 173.

⁴ Phillips, C. W., *Pebbles from Early Ploughs in England in P.P.S.* (1938), iv (N.S.), 338-9; see also Evans, J., *Ancient Stone Implements*, London (1897), 266, fig. 183.

⁵ Corrie, J. M., *op. cit.*, 338.

iron-shod ard, of an asymmetrical plough, and of spades for delving and for cutting peat and turf. Finally the plough pebbles, mostly from reasonably low-lying ground, suggest a heavy type of mould-board plough of early medieval date.

II. SINGLE-STILTED PLOUGHS

In Shetland, Orkney, Caithness, and the Outer Isles, a particular type of plough survived into the nineteenth century. Though formal variants can be distinguished the feature common to all is the single handle or stilt on the left of which the ploughman walked, and it is, therefore, convenient to refer to them as single-stilted ploughs. The term is well attested from as early as the eighteenth century, and distinguishes them clearly from the two-stilted ploughs that eventually replaced them. A technical point that needs to be made clear is that since all have some form of mould-board or a set of mould-strokers at the right side, they cannot be described as symmetrical ploughs as has been done by Haudricourt and Delamarre,¹ though it would not be difficult to remove the asymmetrical features and turn them into symmetrical ards.

Since, however, they are only one stage removed from ards, there is reason for thinking that cultivation has been going on in the Northern Isles with ards or a related form of plough for a period approaching 4000 years, though it would be rash to postulate a tradition of unbroken continuity. Whatever implements were in use when the Vikings started settling are likely to have been modified by those they brought with them or were familiar with at home, and documentary evidence of the seventeenth and eighteenth centuries shows that Norwegian influence lasted on long after these islands passed into the control of the Scottish crown.

A specific statement was made in 1652, at the time of the Protectorate, in the Proposals of Orkney and Shetland, that 'our shyre in all tymes bygone has had Commerce and tradinge with Norrway for importinge of boates for our fishinge and other Timber requisite for ploughinge of the ground which cannot be had elsewhere'.² Presumably the reference is to plough beams, which had to be reasonably substantial and of a particular shape, and therefore not easily come by in treeless islands. It is unlikely that ploughs were brought in ready made, since no close similarities are to be observed between the single-stilted ploughs of Scandinavia and the Northern Isles, though the frame stilt or handle of the extant Shetland ploughs is broadly reminiscent of certain Scandinavian ploughs, e.g. that from Nord-Jämtland illustrated by Leser.³ It is likely, in view of Gifford's remark that the poorer inhabitants of Shetland could not afford to buy imported wood,⁴ that ploughs were made up by the landlords and supplied to their tenants as steelbow goods, or else crudely made by the latter from such driftwood as was available.

It has not been fully realised how much information is available on Scottish single-stilted ploughs. The following table brings together the major sources, area by area, and summarises the main features brought out by each description.

¹ Haudricourt, A. G. et M. J. B.-Delamarre, *L'Homme et la Charrue*, Paris (1955), 191.

² Terry, C. S., ed. *The Cromwellian Union* (S.F.S. 1902), 125.

³ Leser, P., *Entstehung und Verbreitung des Pfluges*, Münster (1931), 165.

⁴ Gifford, T., *Historical Descr. of Zeiland*, London (1786), 52.

TABLE II
SINGLE-STILTED PLOUGHS

District	Description and Source	Team	Control	Technique	Number	Name
SHETLAND	'Plough Socks and Culters slender and little' - (Monteith ¹ 1633)	4 oxen in broad band (abreast)	Driver; side control by ploughman	—	—	—
Fetlar	'A piece of tree for an orderous (beam) of a plough' - (Old-Lore Misc. ² 1732-5)	—	—	—	—	—
Delting	Crooked piece of wood, with slender, pliable piece of oak fastened to ox yokes - (O.S.A., I (1791), 391-2)	Oxen with yokes	Driver, pulling on oxen with ropes round horns; side control	Furrows levelled and clods broken with spades	6	—
Unst	One stilt; double-feathered stock [sic] - (O.S.A., v (1793), 192-3)	2 horses + 2 oxen; 4 horses; or 4 oxen, abreast	Driver; left side control	No ploughing before spring	—	—
Dunrossness	(O.S.A., VII (1793), 393)	4 oxen abreast in Sandwick and Cunningsburgh; 4 horses abreast at Ness	—	—	—	—
Aithsting and Sandsting	See quotation below (p. 293) - (O.S.A., VII (1793), 585-6)	4 oxen abreast	Side control	See quotation below (p. 293)	14	—
Bressay, Burra and Quarff	(O.S.A., x (1795), 196)	—	—	—	6	—
Northmaven	(O.S.A., XII (1794), 355)	—	—	—	No. of ploughs reduced to 26	—
Hibbert 1822 ³ [See the Aithsting and Sandsting account below]						
ORKNEY	Little and light, one stilt - (J. Brand ⁴ 1683)	'Although some of their ground be stony, yet their beasts are weak and unable to go through with a plough of any considerable weight'	Lifted and carried to the other side at the end of a ridge	—	—	—
—	Ploughs had coulter, socks, skys, and lives (see Glossary) - (Proc. Ork Ant. Soc. ⁵ (1734))	—	—	—	—	—

¹ Sibbald, R. (ed.), *Descr. Orkney and Zetland*, Edinburgh (1711), 5.

³ Hibbert, S., *Descr. Shetland Islands*, Edinburgh (1822), 459.

⁴ Brand, J., *Descr. Orkney and Zetland*, Edinburgh (1701), 18-19.

⁵ A 1734 Orkney Inventory in *Proc. Ork. Ant. Soc.*, I (1922-3), 65.

² *Old-Lore Misc.*, IV (1911), 121.

TABLE II (cont.)

District	Description and Source	Team	Control	Technique	Number	Name
ORKNEY (cont.) House or Place of Burray	(<i>Proc. Ork. Ant. Soc.</i> ¹ (1747))	—	—	—	—	'An old stilted plewgh'
	(G. Low ² 1773) [See quotation below,		p. 300]			
	Light ploughs - (J. Campbell ³ 1774)	2 or 4 horses; 2 horses and 2 cows	—	—	—	—
Holme	One stilt (<i>O.S.A.</i> , v (1793), 409)	4 horses yoked 2 × 2; or three abreast (Strath- naver breed)	Carried under the arm round the end of a ridge	—	—	—
Rousay and Egilsay	(<i>O.S.A.</i> , vii (1793), 339)	Small sized horses, brought from Strath- naver at 2 years old, and some from Shetland; 3 or 4 in a team	—	—	Upwards of 200	—
Cross and Burness, North Ronaldsay and Ladykirk	(<i>O.S.A.</i> , vii (1793), 473)	—	—	'Well suited to a light soil, and breaks the ground very well'	<i>Crosskirk</i> 41 ploughs for 492 arable acres <i>Burness</i> 24 for 288 acres <i>Ladykirk</i> 50 for 600 acres <i>Ronaldsay</i> 43 for 344 acres <i>Total</i> : 158	'single handed'
Kirkwall and St Ola	'One stilt and strange kind of irons' - (<i>O.S.A.</i> , vii (1793), 541-2)	—	—	No plough- ing till spring	—	—
Firth and Stenness	'One slit' [sic = stilt] - (<i>O.S.A.</i> , xiv (1795) 126)	—	—	Good for last plough- ing for bere crop; bad in stony, strong ground; especially oatland	—	Side plough
Birsay and Harray	(<i>O.S.A.</i> , xv (1795), 319, 323)	3 horses; 523 horses in parish	—	—	142, the biggest farmers having up to 3	—

¹ *Inventory of House or Place of Burray 1747 in Proc. Ork. Ant. Soc.*, xii (1933-4), 48.² Low, G., *A Description of Orkney (1773) in Proc. Ork. Ant. Soc.*, ii (1923-4), 56 and illus. facing 52.³ Campbell, J., *Political Survey of Britain*, i, London (1774), 666.

TABLE II (cont.)

District	Description and Source	Team	Control	Technique	Number	Name
ORKNEY (cont.) Stronsay and Eday	(O.S.A., xv (1795), 399)	'4 horses abreast, or broad band'	—	Ploughs about 15 acres Sc. (c. 18½ Eng.)	—	Side plough
Westray	(O.S.A., xvi (1795), 252, 260)	4 or 3 horses	—	—	144	Single- stilted
Papa Westray	—	—	—	—	24	—
Sandwick and Stromness	(O.S.A., xvi (1795), 417-18)	Mainly 3 horses abreast; some- times 2, rarely 4. Oxen kept for harrowing or carting peat	'In holding this plough, the ploughman bends to the soil, and may well be de- nominated Curvus arator'	Each tills an average of 9½ acres	227	—
Shapinsay	One slender stilt and a slender beam - (O.S.A., xvii (1796), 228-9)	4 animals yoked abreast, with a straight pole fixed to all their noses, held in the middle by the driver	Driver; and ploughman who 'holds it by this stilt, and directs it by a short batton held loose in his hand for that purpose'	Furrow badly turned, it either stands on its edge or falls back with surface uppermost	—	—
Orphir	One stilt, a small pointed sock, a coultter 'resembling a kail gully', two sticks fastened horizontally to the head of the plough, instead of a mould-board - (O.S.A., xlix (1797) 405, 408)	3 horses abreast, pulled on by halter fixed to midmost one	Driver; plough- man carries pattle, to clean the plough, to serve as a second stilt, and to throw at the horses when necessary	Furrow c. 3 in. deep, and thrown off in a slanting direction	100	—
Evie and Rendall	One stilt - (O.S.A., xx (1798), 249-50)	3-4 horses abreast	—	Bad in stiff soil, good in previously well-tilled soil	—	Side- plough
—	Culter and sock not 2 lb. in weight - (Barry ¹ 1805)	4 abreast; oxen yoked with 'cheatts and haims and breochams'	'The holder . . . lyes on with his side'	No tilling till spring	—	—
—	(Marwick ² 1936)	[See fig. 10:2 and Glossary]	—	—	—	Side- plough, Stiltie

¹ Barry, G., *Hist. Orkney Islands*, Edinburgh (1805), 447. This account, in a different hand at the end of Jo Ben's *Descriptio Insularum Orchadianum* (allegedly 1529) is unlikely to be earlier than the late eighteenth century, since oxen do not seem to have been equipped with collars until this period.

² Marwick, G., *The Old Roman Plough* (Kirkwall 1936).

TABLE II (cont.)

District	Description and Source	Team	Control	Technique	Number	Name
CAITHNESS Reay	(<i>O.S.A.</i> , VII (1793), 575)	—	—	—	181 (type not mentioned but prob. single-stilted)	—
Wick	One stilt called the 'steering tree' covered with a sheep-skin. Coulter not through beam but through key - (<i>O.S.A.</i> , X (1794), 22-23)	4 garrons or oxen abreast	—	—	—	—
Dunnet	Probably single-stilted - (<i>O.S.A.</i> , XI (1794), 253)	4 horses or oxen abreast (tenants' ploughs)	—	—	Most have one, a few have two	—
Watten	(<i>O.S.A.</i> , XI (1794), 266)	4 horses, oxen, or cows abreast drawing by 'theets' (traces)	Driver, holding the cattle tied with halters	Some will turn the mould to a depth of 4 in.	—	—
Latheron	Probably single-stilted - (<i>O.S.A.</i> , XVII (1796), 25-26)	4 animals abreast	—	—	343 (Prob. single-stilted)	—
Halkirk	One stilt; it had 'scarcely a side board' - (<i>O.S.A.</i> , XIX (1797), 32-33)	'Short yoke' of 4 abreast common; 'long yoke' of 2 x 2 rare	Stilt held by ploughman's hand against his right thigh	It 'broke the earth as it turned it, served the purpose of a first harrowing as it went along, and good crops were raised after it'	'For some years past there is none of them to be seen'	—
—	(Sinclair ¹ (1795))	—	—	—	—	Thrapple plough
—	Beam, head or sole, key, land and mould-boards of wood; mould-board had convex side outwards, and was 'ribbed' to break the soil - (Henderson ² 1814)	[See further quotation below]	—	$\frac{1}{4}$ acre ploughed per day	—	Thraple plough
WESTERN ISLES Lewis	Plough only lately known, still only a few - (Walker ³ c. 1765)	—	—	—	—	—

¹ Sinclair, J., *Agric. Northern Counties and Islands of Scot.*, London (1795), 203-4.² Henderson, J., *Agric. Caithness*, London (1812), 56-57.³ Walker, J., *Oeconomical Hist. Hebrides in Trans. Gael. Soc. Inv.*, XXIV (1899-1901), 127.

TABLE II (cont.)

District	Description and Source	Team	Control	Technique	Number	Name
WESTERN ISLES Barvas, Lewis	'A crooked small piece of wood, on the top of which is fixed a stilt or handle' - (<i>O.S.A.</i> , XIX (1797), 266)	4 horses, pulled on by halter	Driver; side control	—	90	—
Stornoway, Lewis	Not unlike the Chinese plough - (<i>O.S.A.</i> , XIX (1797), 248)	—	—	—	—	Single stilted
Harris	4 ft. 7 in. long, one handle, mould-board fastened on by 2 leather thongs, sock and coulter bound together at the point by a ring of iron - (Walker, ¹ c. 1765)	4 horses abreast	—	—	—	—
—	(Buchanan, ² 1793)	2 or more little horses	Ploughman went with left side foremost	—	—	Cromman gadd
North Uist	One handle. Little known beyond the Long Island. Given up by principal farmers - (<i>O.S.A.</i> , XIII (1794), 307-8)	—	Ploughman holds stilt in right hand, and a lash in his left	—	—	—
South Uist	Discontinued no more than 20 years ago - (<i>N.S.A.</i> , XIV (1845), 191)	—	—	—	—	Cromnan-gadd
Barra	Discontinued - (<i>N.S.A.</i> , XIV (1845), 211)	'Required the labour of 4 men and 3 horses'	—	—	—	Cromna-gadd
—	Crooked tree, with square mortise for plough-head, adjustable by wedges; small stilt; vertical coulter - (Hogg ³ 1881)	4 ponies abreast	Stilt held with right hand, pattle in left hand; driver pulled a pole fixed across the ponies' noses	—	—	—
—	(Dwelly ⁴) [See fig. 10:3, and Glossary]	—	—	—	—	Crannan-gadd

¹ *ibid.*, 138, and in *Scot. Hist. Rev.*, XIX (1921), 43.² Buchanan, J. L., *Travels in the W. Hebrides*, London (1793), 153.³ *The Ettrick Shepherd in Lewis in Sc. Geog. Mag.*, 58 (1942), 67-71 (from J. Hogg's *Letters to Sir Walter Scott*, 1881).⁴ Dwelly, E., *Illustrated Gaelic Dictionary* (1930), s.v.

(1) *Distribution and Numbers*

From Table II it will be seen that the single-stilted plough was found in the Northern and Outer Isles and in Caithness. There is seventeenth-century evidence for it in Shetland and Orkney, but not elsewhere. It is known that the machars of Harris and Taransay were ploughed in preparation for oats in the mid-sixteenth century,¹ and that in the 1690s the brown, sandy soil of Colonsay received three ploughings, that there was a type of plough drawn by four horses in North Uist, and that the natives of Heiskir made draught ropes for attaching their horses to the plough out of long strips of seal-skin,² but there is no means of telling whether these ploughs were single or double stilted.

In the Northern Isles, the single-stilted plough was almost universal, though by the end of the eighteenth century its numbers had been much reduced by the increase in spade cultivation resulting from artificially created social and economic factors. In the 1790s, single-stilted ploughs in the four parishes where numbers were specified in the *Old Statistical Account* totalled 52; seven parishes of Orkney were served by no fewer than 996 ploughs at the same period. As each plough was capable of tilling 12 or more acres, the size of the Orkney crop must have been considerable. Indeed, Orkney exported grain to Norway and Shetland until the eighteenth century, and in the early sixteenth century, Boece claimed that Orkney bere made the strongest ale in Albion.³ If the numbers given for the parishes of Reay and Latheron in Caithness apply to single-stilted ploughs, as is not unlikely, then this county was served by over 500. In the Outer Isles there was a concentration of 90 in the parish of Barvas, Lewis, in the 1790s. Statistically, therefore, Orkney and Caithness were the areas of most intensive cultivation by the single-stilted plough, though the reduction in numbers in Shetland has to be borne in mind.

One of the main problems here relates to the origin and distribution of the single-stilted plough of the W., the *crann-nan-gadd*. Walker's remark in 1765 that it was something new in Lewis is corroborated by sixteenth and seventeenth century accounts of spade cultivation there, and indeed a high proportion of the arable acreage in Lewis is still so cultivated. It looks as if the *crann-nan-gadd* spread to Lewis, presumably from Harris, about the mid-eighteenth century. The evidence shows its existence in the Long Island, the Uists, and Barra. It is not certain that it was found in the Inner Isles or the Mainland. Logan claimed that it was used on farms in Argyll till about 1810, but his evidence is vitiated by his statement that 'in some places it was called the Rotheram plough', which is an entirely different thing.⁴ However, the fact that the *crann-nan-gad* in the National Museum came from Islay may support Logan's extension of the distributional pattern, though there is, unfortunately, no background information to prove that this plough was actually used in Islay. Pending more definite evidence, it is shown in the distribution map (fig. 8) as confined to the Outer Isles.

¹ Munro, R. W. (ed.), *Monro's W. Isles of Scot.*, Edinburgh and London (1961), 80, 86.

² Martin, M., *Descr. W. Islands of Scotland*, Glasgow (1884), 53, 65, 248.

³ In Brown, P. Hume, *Scotland Before 1700*, Edinburgh (1893), 92.

⁴ Logan, J., *Scottish Gaël*, II, London (1831), 89.

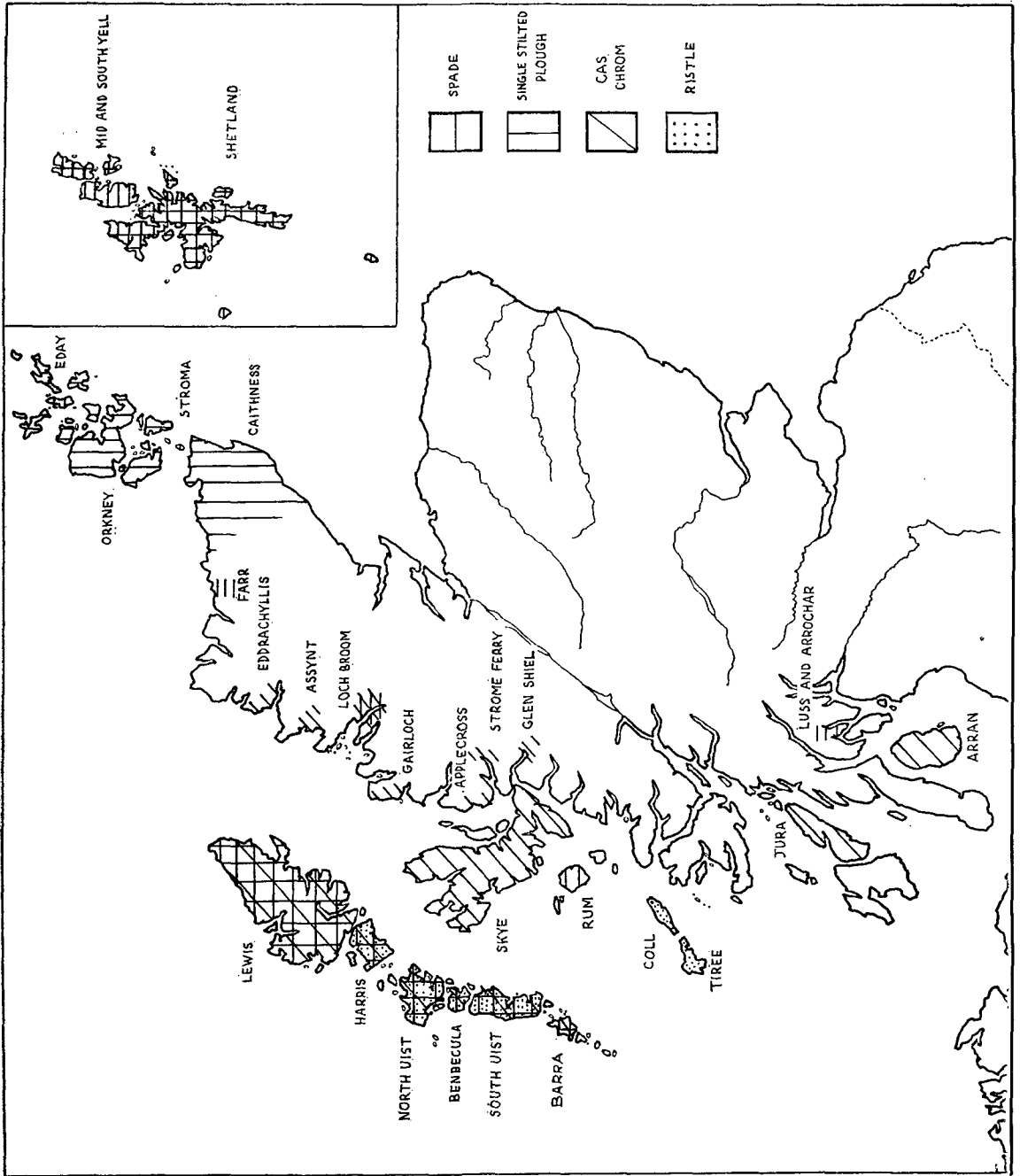

FIG. 8. Distribution of the single-stilted plough, *cas chrom*, *cas dhrach* and *ristle* from literary sources of the eighteenth to nineteenth centuries

(2) *Team and man-power*

The maximum number of animals in the team of the single-stilted plough seems to have been four. At the end of the eighteenth century, oxen were more commonly used than horses in Shetland, though teams of mixed oxen and horses were known in Unst, and of horses alone in the Ness district of Cunningsburgh. In Orkney, teams of horses were in the majority, and a yoke of three abreast was as popular as one of four abreast in the more prosperous parts. The three horse team is in all likelihood to be related to the considerable import of sturdy horses from Strathnaver.¹ Caithness farmers used horses or oxen abreast impartially, and in the Outer Isles only horses are mentioned. The earliest sources refer to oxen, and the linguistic evidence also points to the conclusion that plough teams were commonly of oxen in earlier times. In Orkney, the four horses yoked abreast were named, from right to left facing



FIG. 9. An ox yoke from the White Moss, Shapinsay, Orkney, from *P.S.A.S.*, vi (1864-6), 398

the team, the *fur-horse*, the *fur-scam*, the *volar-scam*, and the *outend-horse*.² The *fur-horse* was the horse that walked on the ploughed land (first recorded 1825³), and the *outend-horse* was the one at the opposite side. The *fur-scam* walked in the furrow, and its mate, the *volar-scam*, on the land. *Volar* is from Old Norse *vollr*, a field, and *scam* from Old Norse *skammr*, short. To understand these terms, the team has to be changed into oxen, yoked as in the Aithsting and Sandsting account with the outer oxen linked by a long wooden yoke, the inner pair by a short one. It is to this short one that the term *scam*, sc. 'short-yoke ox', refers. Jakobsen glosses the word *skammjok* from Shetland as 'the yoke which is borne by the two inside oxen; a shorter yoke in comparison with the longer *utjok* which is borne by the two outside oxen'.⁴ One example of a *skammjok* has been preserved in the National Museum since 1868. It came from under 6 ft. of peat in the White Moss, Shapinsay, Orkney (fig. 9). Clearly, the Orkney terms have been transferred from oxen to horses, and the Norse origins of the words *scam* and *volar* implies that a four-ox team yoked abreast may go back to Norse times in the Northern Isles.

The 'long yoke' of four animals two by two is rare. It occurred in the parish of Holme in Orkney as one of the yoking arrangements, and similarly in Halkirk, Caithness. It seems to be an eighteenth-century innovation as far as single-stilted ploughs are concerned, though it may have been in use earlier on a rectangular-framed, two-stilted plough of a light type known from Caithness and the Highlands.⁵

text continued on p. 292

¹ *Old-Lore Misc.*, II (1909), 192-3; III (1910), 74-75.

² *N.S.A.*, xv (1845), 96.

³ Jamieson, J., *Scottish Dictionary*, Edinburgh (1825), s.v.

⁴ Jakobsen, J., *Dictionary of the Shetland Norm*, London (1928), s.v.

⁵ McGaw, B. R. S., in *Scottish Studies*, vi (1962), 218-23, Pls. X, XI.

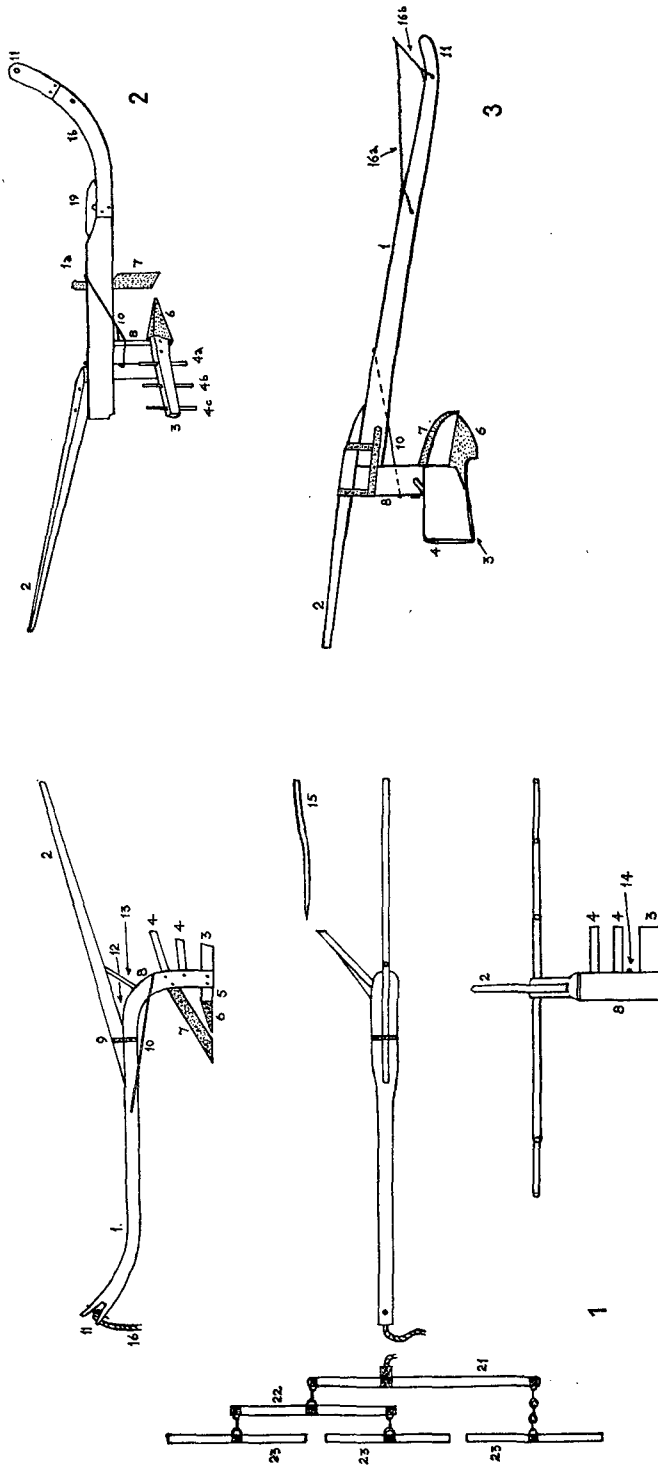

FIG. 10, 1-3

TABLE III
GLOSSARY, AND KEY TO NUMBERED FIGURES (fig. 10)

<i>Shirreff,</i> 1814 (O) ¹	<i>Marwick,</i> 1903 (O) ²	<i>Names from</i> <i>Other Sources</i>	<i>Gaelic Names</i> <i>from Dwelly</i> ³	<i>Standard Name</i> <i>or Description</i>
1. Arr-trees (O.N. <i>arðr</i> , plough)	Stang (1a) and foregill (1b) (O.N. <i>stǫng</i> , a pole; the second element of <i>fore-</i> <i>gill</i> may be a development from O.N. <i>kjǫl</i> , keel, cf. Norw. dial. <i>kjǫl</i> , bottom part of a plough)	Orderous, 1734 ⁴ (S). Astrees, 1825, Jamieson (S). (O.N. <i>arðr</i> , plough + O.N. <i>áss</i> , pole, beam)	Earrghas	Beam
2. Oure-tree (Sc. <i>ower</i> = over, upper)	Stilt, hannal (handle)	Steering-tree, <i>O.S.A.</i> , x (1794), 23 (C)	Làmh-chrann	Stilt ⁵
3. Sky (O.N. <i>skið</i> , piece of wood, board)	Sproll	Sky, <i>Proc. Ork.</i> <i>Ant. Soc.</i> (1734) (O) ⁶	Ùirthilleach	Corresponds to the ground- wrest
4. Earth-skies, ear-skies, lug-skies. (prob. O.N. <i>arðr</i> , plough + O.N. <i>skið</i> , board)	Nether ski (4a), millya ski (4b), ivverski or hirska pin (4c) (O.N. <i>nidr</i> , down; <i>milli</i> , between; <i>yfir</i> or <i>efri</i> , upper; hirska = stony ground)	Ear-sky, 1825 Jamieson (O) Erskaï, 1908 Jakobsen (S)	Bord-ùireach	Mould-strokers or mould board
5. Merkie pin (<i>S.N.D.</i> sug- gests Norw. dial. <i>merg</i> , marrow + <i>kolv</i> piece of wood, but this is uncertain)	Markal pin	Mercal, <i>O.S.A.</i> , vii (1793), 585 (S); 1825 Jamieson (O); 1908, Jakobsen (S)	Meirgeal (<i>S.N.D.</i> thinks this is a borrow- ing from Norse, but ? rather from Orkney Norn)	Triangular pin mortised into the plough head to hold the sock, = the share beam
6. Sock	Sewch, sewchar, or sock	—	Soc.	Share or sock

¹ Shirreff, J., *Agric. Orkney and Shetland*, Edinburgh (1814).² Dwelly, E., op. cit., s.v. *Crann-nan-gad*.³ The term *stilt* is used erroneously for the rear-piece by Jirlow and Whitaker in *Sc. Studies*, 1 (1957), 75 ff.⁴ *Proc. Ork. Ant. Soc.*, 1 (1922-3), 65.⁵ Marwick, G., op. cit.⁶ *Old-Lore Misc.*, iv (1911), 121.

TABLE III (cont.)

<i>Shirreff, 1814 (O)</i>	<i>Marwick, 1903 (O)</i>	<i>Names from Other Sources</i>	<i>Gaelic Names from Dwelly</i>	<i>Standard Name or Description</i>
7. Coulter	Cooter	—	Coltair	Coulter
8. Live or life (<i>S.N.D.</i> thinks from <i>Sc. luif</i> , palm of hand; but not certain)	Sewchar stang- post or beam	Live, <i>Proc. Ork. Ant. Soc.</i> (1734), (O). ¹ Head, <i>O.S.A.</i> , vii (1795), 585-6. Stock, <i>O.S.A.</i> , v (1793), 192-3. Key, <i>O.S.A.</i> , x (1794), 23	Màs a' chroinn (with an iron plate, cìasan, to protect the bottom)	Rearpiece
9. Hass spang				
10. Thraws spang (<i>O.N. hals</i> , neck)	Bridal	—	Na goid	Iron bands
11. Mow, contain- ing the mow- pin (<i>Sc. mow</i> =mouth; <i>O.N. muli</i> , mouth, muzzle)	Kyolks, con- taining the trauchle pin. (<i>O.N. kjálki</i> , jaws)	Mool-iron, 1929, Marwick (O); mull, 1908, Jakobsen (S)	Sròn. It was iron shod, and ran on the ground	Muzzle
12. Nic or a(r)se	—	—	—	Angle between stilt and rearpiece
13. Steer-pin	—	—	—	Strut between stilt and rearpiece
14. —	—	—	—	Iron staple for pressing down with the pattle
15. Pattle	—	—	—	Plough staff
16. Soam, or draught (usually <i>c.</i> 5 ft. long)	Trauchle soam	—	(16a) An druim mór, long part of rope (16b) An druim beag, short part of rope	Draught rope
17. —	Savir soam Dotmel	—	—	Saving rope, linked with dotmel

¹ *Proc. Ork. Ant. Soc.*, 1 (1922-3), 65.

TABLE III (cont.)

<i>Shirreff, 1814 (O)</i>	<i>Marwick 1903 (O)</i>	<i>Names from Other Sources</i>	<i>Gaelic Names from Dwelly</i>	<i>Standard Name or Description</i>
18. —	Dotmel	—	—	Little piece of wood within jaws of plough. This arrangement prevents the trauchle pin from snapping under a sudden strain
19. —	Nobe	—	—	Strengtheners over or under join between stang and foregill
20. —	Crobe	—	—	Strengtheners under join
21. Master-tree (4 ft.)	—	Ammle, amble, 1814 Henderson ¹ (C); 1907 Nicolson (C) 63-64; 1908 Jak. (S); 1929 Marwick (O). (cf. Dan. and Swed. dial. <i>hammel</i> , Norw. <i>humul</i> , swingle-tree)	—	Yoke
22. Twa beast tree (2½ ft.)	—	Twa's ammel, 1907 Nicolson (C)	—	Swingletree to which two others are attached
23. E'e (one) beast tree (20 in.)	—	Sma' ammel, 1907 Nicolson (C)	Na greallagan (plural)	Swingletree

Abbreviations used in Glossary

C = Caithness.

O = Orkney.

S = Shetland.

Jamieson = J. Jamieson, *Scottish Dictionary*, various editions.Jakobsen = J. Jakobsen, *Dictionary of the Shetland Norn* (London), 1928.Marwick = H. Marwick, *The Orkney Norn* (Oxford), 1929.Nicolson = D. B. Nicolson in J. Horne, *County of Caithness, Wick* (1907), 63-64.S.N.D. = *Scottish National Dictionary*.¹ Henderson, J., op. cit., 56.

As Payne points out, it is represented in the Bronze Age rock engravings of the Italian Maritime Alps, and in Wales had supplanted the team of four abreast by the end of the Middle Ages.¹ In Scotland, however, the team of four abreast survived well into the nineteenth century.

An essential part of the team was the driver (fig. 13: 1-2). He walked backwards in front of it, pulling the animals on by ropes round their horns, by halters, or by a pole fixed across their noses. He carried a lash in his hand, using it to make the animals pull as equally as possible so that the furrow breadth could be better regulated.² According to Captain Burt, the driver kept the four animals a little apart in the middle, so preventing the new furrow from being trodden down.³ Logan is alone in suggesting that the driver put his arms about the necks of the two central animals to avoid falling.⁴

In addition there was the ploughman's assistant, usually but not invariably a boy, whose job was to press on the middle of the beam to keep the plough in the soil (Pl. XLVII, 1), and to clean the loose earth out of the working parts at the end of the rig. This earth was allowed to accumulate in a mound, in Orkney practice, and was later carried back to the rig in baskets.⁵ Ploughs of the Shetland type, with a frame handle, do not seem to have needed the presence of an assistant.

It will be apparent that the single-stilted plough required a labour force of four animals and two or three persons. It must be made clear, however, that this labour force and its deployment, was in no way confined to the single-stilted plough. It was equally characteristic of the light, rectangular framed, two-stilted ploughs that have been recorded in the fringe of the Highlands from Caithness through Perthshire down to Galloway.

(3) Terminology

Fig. 10 and Table III (pp. 288-91) give the terminology of the single-stilted plough and its parts. Wherever possible, etymologies are given, which, taken together, show Norse influence to have been strong in the Northern Isles and Caithness. Only one Gaelic name, on the other hand, can have a Norse origin even tentatively ascribed to it. In each case, the standard name or description is given as far as possible according to the names used in *Research on Ploughing Implements*⁶ though standard equivalents do not always exist.

(4) Typology and Structural Features

Illustrations, photographs, and surviving examples (Table IV) of single-stilted ploughs show that they fall into three or possibly four geographically and to some extent typologically differentiated groups. There are indications that some of the points of difference developed comparatively recently, post - 1800.

¹ Payne, F., in *Arch. J.*, civ (1947), 83-87.

² Henderson, J., op. cit., 56.

³ Burt, E., *Letters from a Gentleman in the North of Scotland*, II, London (1759), 134-8.

⁴ Logan, J., op. cit., 90.

⁵ Marwick, G., op. cit., 4-5.

⁶ Published by the International Secretariat for Research on the History of Agricultural Implements (Copenhagen 1956).

(i) *Shetland*. The Shetland plough used in the parish of Aithsting and Sandsting in the eighteenth century was described as follows:

A crooked piece of wood, bent (naturally) almost to a right angle, forms the beam; to which is fixed a piece of oak stave, about 7 feet long, which must be very pliable, and yield to the pressure of the driver's hand, when he would deepen his fur (furrow). The coulter stands almost even up and down, and is always too short. A square hole is cut through the lower end of the beam, and the *mercal*, a piece of oak about 22 inches long, introduced, which, at the other end, holds the sock and sky.¹

This matches precisely the 1793 illustration of an Unst plough, and also Hibbert's one (fig. 13: 2-3), though his description is largely borrowed from the account above,² and his drawing may have been influenced accordingly.

The three features brought out by eighteenth-century sources are: the coulter mortised vertically into the horizontal part of the beam; the long *mercal* or plough-head; and the mould-strokers at the right side of the plough. The three extant Shetland ploughs (fig. 11: 1-2), all of nineteenth century date, have similarly fitted coulters. The plough-head, however, has been sophisticated into something more nearly resembling the share-beam of a conventional plough. The fore-end of the *sky* or ground wrest is joined to the plough-head to form a neck on to which the share is socketed, and the rear-end of the *sky* is butted against the lower of a pair of short mould boards set at different angles. These twin mould boards look like joiner made features, possibly developed after the introduction of sown grasses gave rise to tougher swards that required turning over rather than breaking up. If so, this type of mould-board cannot be regarded as a traditional feature, as Payne implied,³ but serves as a distinguishing feature of the nineteenth-century Shetland ploughs. The long plough-head is present in all the Shetland ploughs. Associated with it there is usually a frame handle or stilt with a short handgrip that lies immediately above the rear-piece of the plough. With such an arrangement, the ploughman could exert direct downward pressure to keep the plough in the ground, and an assistant to press on the beam was then unnecessary. Where he is present, in the Outer Isles, Caithness and Orkney, the fore-end of the stilt is attached immediately above the rearpiece or only a little in front of it on top of the beam, sometimes supported by a short strut or by an extension upwards of the rearpiece, producing a faint reflection of the Shetland frame handle, or else having no strut at all but nevertheless protruding several feet back beyond the head. This is in the strictest sense a 'steering (directing) tree', on which great downwards pressure was not intended, so that the services of an assistant were rendered necessary.

As regards the shape of the beam, only the Unst plough has any degree of downward curvature (fig. 13: 3).

(ii) *Orkney*. Orkney provides the earliest recorded illustration of a single-stilted plough and a three horse team on William Aberdeen's estate plan of c. 1770 (fig. 13: 1). The beam is downwards curving, like that of the Unst plough, and it has the

¹ *O.S.A.*, vii (1793), 585-6.

² Hibbert, S., *Descr. Shetland Islands*, Edinburgh (1822), 459.

³ Payne, F., in *Arch. J.*, civ (1947), 88.

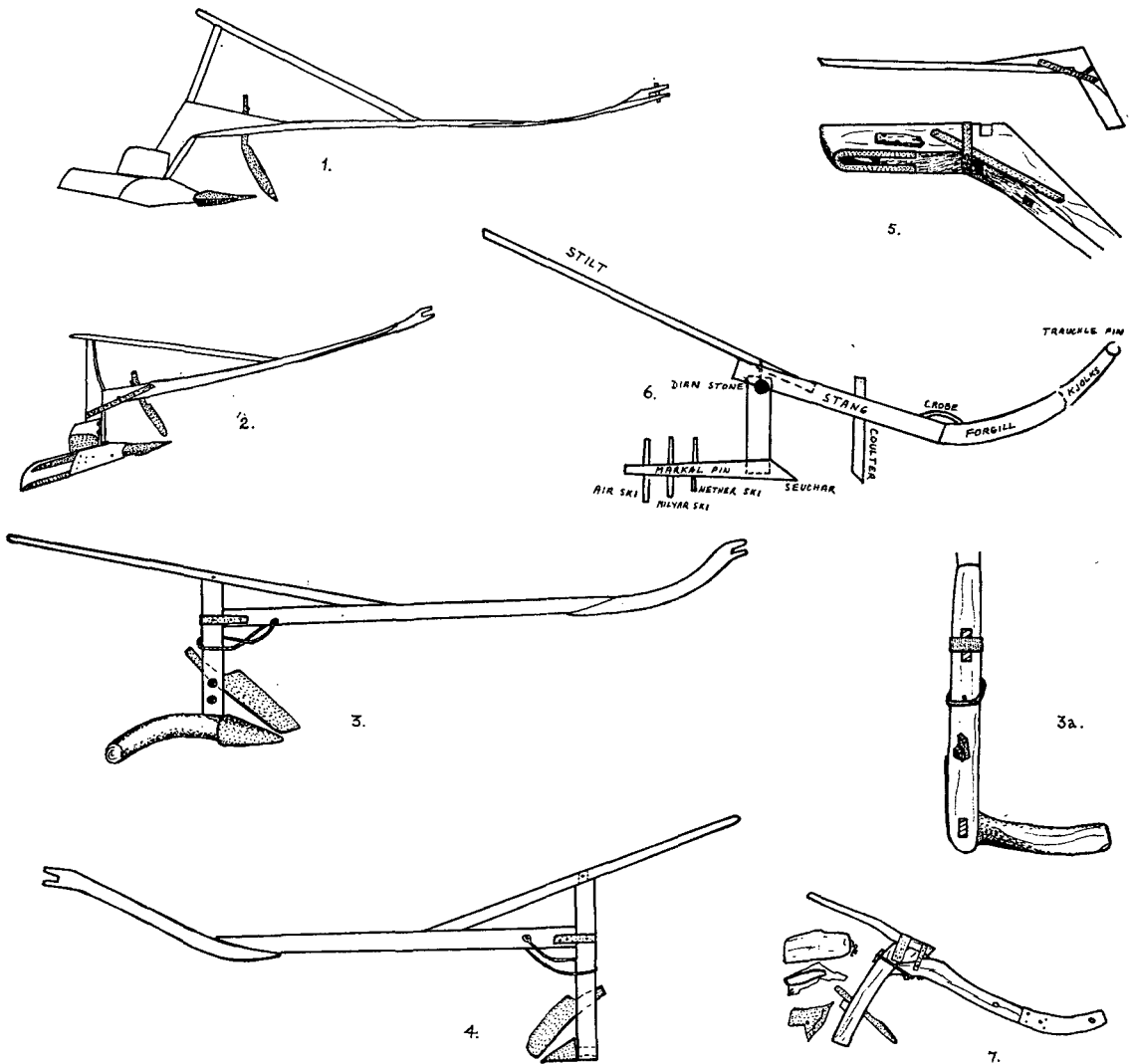

FIG. 11. 1-2. Shetland ploughs in the N.M.A.S.: PAA 2 (formerly MP 82) and PAA 9 (formerly MP 585) respectively. In 2 the beam is mortised into the rearpiece, which is carried up to serve as a strut for the stilt. 3. In Tankerness House, Orkney; 3a. The angled mortice of the coulter; 4. In Stromness Museum, Stromness, Orkney; 5. The remaining part of the beam and rearpiece of a plough in Tankerness House; 6. An Orkney 'side-plough' sketched by John Firth in 1914, and copied by A. W. Johnston in 1915. From the Johnston papers, by courtesy of E. Macgillivray, Librarian, Kirkwall. The *dian stone* was a holed pebble carried to bring luck; 7. *Cram-nan-gadd* in the N.M.A.S., PAA 6 (formerly MP 388)

same arrangement of mould-strokers. It differs, however, in three respects. It has an apparently much shorter plough-head, the coulter is mortised at an angle into the rearpiece, and it does not have the same kind of frame handle. These three features are repeated in Shirreff's 1814 diagram (fig. 10: 1), and on four of the six surviving

examples (fig. 11: 3-4). The chief difference between Aberdeen's plough and nineteenth-century ploughs is that the beams of the latter curve up at the front, not down, and since this is also true of the three Shetland ploughs in the National Museum, it may be a feature not much older than 1800. The downward-curving beam, possibly associated with a form of yoking involving a long draught-rope, is likely to have been the earlier form.

Four of the Orkney ploughs have coulter fixed in the rearpiece in a mortise cut at an angle of about 30° to the horizontal (Pls. XLV, 1-2, XLVI), so that the blades meet the land at this angle. This placing of the coulters to 'gripe in on the unploughed land',¹ in conjunction with their considerable breadth, makes them act as incipient mould-boards, so that the ploughs are fully capable of carrying out even a task such as ridging potatoes (Pl. XLVII, 2).

Whether or not this arrangement of the coulters is old in Orkney is uncertain, but the dimensions of the coulters, very broad in relation to their length, and with a short tang, are strongly reminiscent of coulters from Irish crannogs whose contents showed Viking influence.² The Orkney coulters are c. 15 in. long by 4½ in. to 4¾ wide, the tang 6 to 7 in.; one from Ballinderry Crannog was 19 by 4½ in. with a 7-in. tang, and one from Lagore was 17 by 4½ in. with a 7-in. tang.

The shares of the Orkney ploughs (fig. 12) are small, and amount to little more than metal shoes over the conjoint ends of the plough-heads and ground-wrests (Pl. XLV, 3). Their pointed oval form is reminiscent of the shares of possibly Viking date from Ireland and Scotland to which reference has already been made. The implication is that this Orkney group of single-stilted ploughs, with their angled coulters, pointed oval shares, and mould-strokers, preserves features likely to be of some antiquity, and it may be that the sheer weight of numbers of single-stilted ploughs at work in Orkney inhibited change and the development of individual features.

To this latter suggestion, however, there is one exception. Apparently towards the end of the nineteenth century, a type of apparently very local distribution appeared in Orkney. Its chief distinguishing feature is its *sky* or ground-wrest in which three upright wooden pegs are set. Its coulters are mortised vertically into the beam. It was first illustrated photographically by Firth in 1920, and again in Marwick's booklet in 1936 as a frontispiece to a lecture first delivered in 1903. A rough sketch was made by John Firth and copied by A. W. Johnston in 1915³ (fig. 11: 6). The evidence, therefore, belongs entirely to the twentieth century, and nothing has come to light to support Marwick's statement that 'this kind of plough was in *general* use in Orkney about one hundred and twenty years ago'.⁴ Indeed, the most likely solution to the problem of its origin is that it was a local adaptation of the older type by a late nineteenth-century joiner of an ingenious turn of mind who invented the upright pegs to give an improved harrowing action, and the *savir soam* and *dotmel* device at the forepart of the beam to prevent damage to the draught pin.

¹ Shirreff, J., *Agric. Orkney*, London (1814), 52.

² Duignan, M., *op. cit.*, 133, 136.

³ I am indebted to Mr Evan Macgillivray, Public Library, Kirkwall, for drawing my attention to this illustration amongst A. W. Johnston's papers.

⁴ Marwick, G., *op. cit.*, 2.

Firth's term, *air ski*, for the outermost upright peg, shows that Marwick's term *ivver ski* is a corruption of the well authenticated *ear(th) sky*, and tends to confirm that this plough was a novelty to whose parts some of the names for the older plough had been transferred.

There is also in Tankerness House the rearpiece and back part of the beam of a plough clearly similar in construction to those from Shetland (fig. 11: 5). The fact that it stands alone amongst the Orkney ploughs may suggest that it was brought at

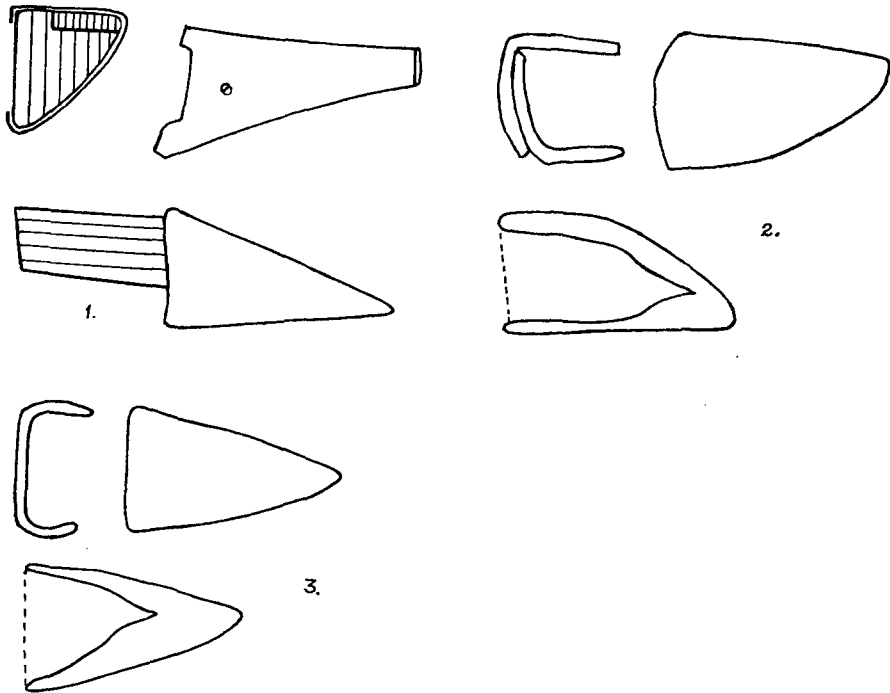

FIG. 12. The shares of Orkney ploughs: 1. As in fig. 11: 4, showing the *mercal pin*; 2. As in fig. 11: 3. 3. As in Pl. XLV, 3

some date from Shetland, but at any rate it forms the third in the Orkney range of types.

(iii) *Caithness*. No single-stilted ploughs survive from Caithness, nor are there any illustrations, and the documentary evidence is not entirely clear. The Caithness type resembled the main Orkney group with a coulter set into the rearpiece (Table II) but there may have been differences in the form of the mould-board. Sir John Sinclair, who called it the 'thrapple plough', said it had 'two mould boards, one at each side,'¹ which suggests, as Payne has said, that it was a reversible (one-way) plough. If this were so, it is puzzling that Sir John, himself a Caithness proprietor, did not say so more specifically. Furthermore, his statement is not supported by Henderson's very full description of the 'thrapple plough' as follows:

¹ Sinclair, J., *op. cit.*, 203-4.

The beam was more bent, and nearly the same length with that of a modern plough, with a head or sole, key, land and mould-boards, all of wood; the mould-board having its convex side outwards, and ribbed, so as to break the mould, as the furrow passed off it; it had only one stilt, projecting from the centre of the head or sole, an iron coulter and sock, with or without a feather, as the land was grassy or stony, with a piece of wood fixed on the end of the beam by two wooden pegs, which served as a muzzle, and a band made of birch twigs, or thongs of raw leather, embraced the notch of the muzzles, and an iron hook in the centre of the amble (yoke), by which the plough was pulled along.¹

Logan also referred to the mould-board as 'ribbed or furrowed, in order to break the land',² and is likely to be borrowing from Henderson.

The situation, therefore, seems to be that Sir John made a mistake in observation or in reporting, and that the Caithness plough had the same type of convex *sky* or ground-wrest, with a pair of 'ribs' or mould-strokers, as the Orkney plough. It would then fall into the same group as the Orkney plough. If, however, Sir John was right, allowance must be made for a Caithness group with a special type of mould-board.

(iv) *Outer Isles*. The single-stilted plough or *crann-nan-gad* of the Outer Isles is known in descriptions from the second half of the eighteenth century (Table II), and the earliest illustration dates from 1895 (Table IV). This shows a team consisting of a heifer and a woman, and a ploughman standing sideways on at the left of the plough, pressing down on the short single stilt (fig. 13: 4). The mould-board is a flat, wooden board fixed at the front by a thong, and the share is feathered and very broad. A long coulter with a downcurved tip is mortised into the rearpiece. The most striking feature is the sharp downwards curvature of the forepart of the beam. The muzzle, indeed, is running on the ground, and the point of attachment of the traces has been set back along the beam. A short cross-bar fixed to the beam a little way in front of this point does not appear to have any function in this drawing, though it probably has something to do with attaching the traces.

The drawing can be accepted as reasonably accurate, since it bears out the evidence of Dwelly and the *crann-nan-gad* in the National Museum, except that those show trace attachments at two points (figs. 10: 3, and 11: 7) instead of one.

The forepart of the downcurved beam of the *crann-nan-gad* ran continuously on the ground, and for this reason, according to Dwelly, was sometimes iron shod underneath to prevent wear. In rocky ground, this was a good arrangement for keeping the plough steady, for helping to control the depth, and for allowing the share to be readily lifted over earthfast rocks or outcrops by simply raising the stilt. It served the same purpose as a foot or wheel and is a device found in other parts of the world.³ Downward curvature of the beam has already been shown to be present in the early Orkney and Shetland ploughs, though not to such an extent that it has given rise to any special development in the trace attachments. Neither is it likely that the forepart of the beam ran continuously on the ground, though when turning at the end of a rig, the ploughman could raise the stilt on to his shoulder and let the beam run along the ground.⁴ The older type, however, does have shallow downward curvature, and possibly the *crann-nan-gad* exaggerated the form as a regional response

¹ Henderson, J., op. cit., 56-57.

³ Examples are illustrated in Leser, P., op. cit.

² Logan, J., op. cit., 89.

⁴ Marwick, G., op. cit., 7.

to a particularly rocky environment. The problem is complicated by a print dated *c.* 1800 showing a ploughing scene on level ground on the outskirts of Glasgow (Pl. L). Here, the plough is being drawn by two horses in line ahead, the foremost driven by a man with a lash. It has two stilts and appears to have a rectangular frame. The forepart of the beam curves down sharply and the trace attachment is very far back on the beam. Clearly this is a mongrel, a cross between a rectangular-framed plough and a *crann-nan-gad*. There is no other record of it, and whether it was a common or uncommon type is not known. It may imply that the *crann-nan-gad* was possibly more widespread than its recorded distribution in the Outer Isles would suggest (fig. 8), if it was able to influence the form of Lanarkshire ploughs. Alternatively, the influence may have been the other way round, and the *crann-nan-gad* may have borrowed the sharply curved beam from two-stilted ploughs, and therefore from the S. rather than from the N. The curved beam occurs, for instance, on representations of ploughs in fourteenth-century manuscripts in England.¹ The stages between are lacking at present, and the line of development of the form in Scotland must remain in the realm of speculation till further evidence comes to light.

The *crann-nan-gad* resembles other single-stilted ploughs only to a limited extent. Its beam, method of trace attachment, and mould-board are all different. As with Orkney and Caithness ploughs, its coulter is mortised into the rearpiece, but the mortice is straight and the coulter is long and narrow, with a down-curved, beak-like point. The share is socketed on to the plough-head or *meirgeal*, which is mortised into the rearpiece in the usual way, but it is a very broad, feathered share of a kind suitable for paring shallow soils covered with grass or heath.² The difference between the *crann-nan-gad* on the one hand, and the Shetland/Orkney/Caithness ploughs on the other, are indeed considerable enough to suggest that different origins must be sought for it, and research into what Ireland had in the way of single-stilted ploughs, for example, could be helpful.

(5) *Control and Ploughing Efficiency*

(i) *Depth.* Control of depth on all single stilted ploughs was exercised by the ploughman alone, or in collaboration with an assistant. The ploughman walked on the left side of the plough, either leaning his weight on the rearpiece, or facing forward, holding the stilt firm against his thigh, which was protected by a sheep skin.³ He carried a pattle or plough-staff to clean the plough, to heave at the animals occasionally, and, in Orkney, to act as a second stilt when more depth was required. Shirreff's diagram shows a staple at the back of the plough-head 'for placing the end of the pattle-tree into, in order to make the plough keep the ground, or go deeper, by laying on more pressure'.⁴ This agrees with late eighteenth-century accounts from the parishes of Orphir and Shapinsay. The Orkney plough-staff had, therefore, to be a pointed stick, lacking the little spade-shaped head that was common elsewhere (fig. 10: 1, No. 14). Depth control could also be exercised by pressure on the beam

¹ Steensberg, A., in *Acta Arch.*, vii (1936), 270-1; Jope, E. M., *op. cit.*, ii, 90.

² Jirlow and Whitaker, *op. cit.*, state erroneously that the *crann-nan-gadd* in the National Museum has lost its sock, and that it has never had a coulter. Both are present, however.

³ Logan, J., *op. cit.*, 89.

⁴ Shirreff, J., *op. cit.*, 51-52.

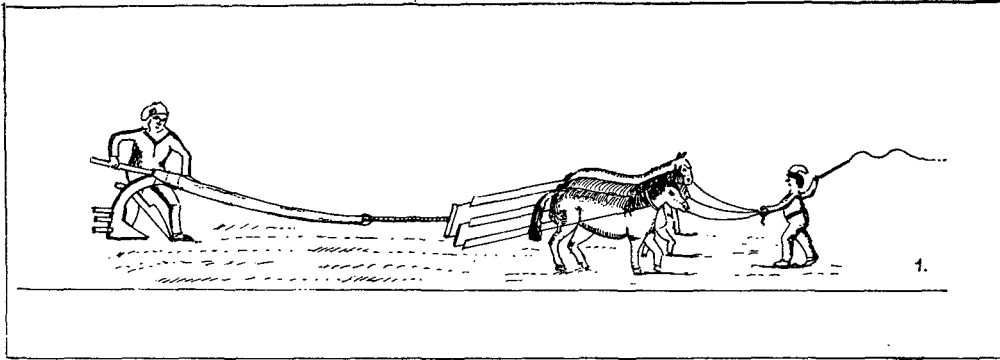

FIG. 13:1. The earliest illustration of an Orkney single-stilted plough with a three-horse team, c. 1770, on a plan by William Aberdeen. By courtesy of E. Macgillivray, Librarian, Kirkwall

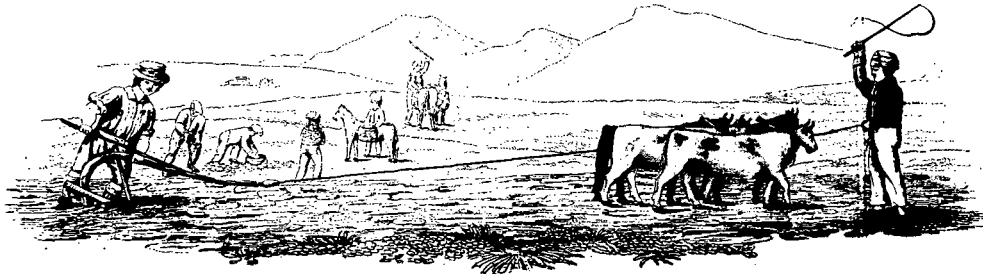

FIG 13:2. A Shetland plough drawn by four oxen. From S. Hibbert, *Descr. Shetland Islands*, Edinburgh (1882), Pl. VI, fig. 20

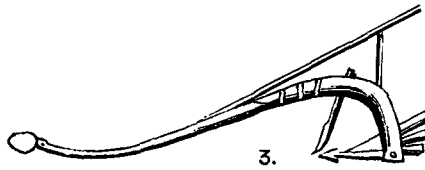

FIG. 13:3. The earliest illustration of a Shetland single-stilted plough, 1793. From the *Old Stat. Acc.*, v, frontispiece

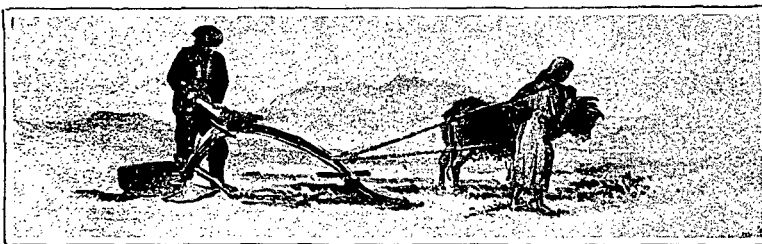

FIG. 13:4. The earliest illustration of the *crann-nan-gadd* from *Scottish Home Industries*, Dingwall (1898), 1

by an assistant, by wedging the plough-head above or below its tongue in the mortice in the rearpiece,¹ and by having a beam with a downward curving forepart that could serve as a foot. In the Shetland plough, the slenderness and pliability of the forepart of the beam, which yielded under pressure, also seems to have been a factor in depth control.

(ii) *Width*. Control of the furrow-width could be exercised, as in Lewis,² by wedging one side or the other of the tongue of the plough-head mortice. It was also influenced by the driver's ability to make his team pull steady, but where the coulter was angled to tear into the land it must have been difficult to achieve an even furrow width.

(iii) *Efficiency*. Although the plough was light enough to pick up in one hand, it apparently was not easy to pull. According to one writer, 'the structure of the Orkney plow requires to have the beam very long, and a very long rope fixed to the muzzle of it, all which throwing the horses at a great distance from it, renders the draught heavy and toilsome, and indeed this with the shape and method of placing the irons, makes this small one . . . as hard for the horses to work as the heaviest Scots plow'.³

He also said, as did the writer on Shapinsay in the *Old Statistical Account*, that the mould-strokers simply shifted the furrow slice from its place, often leaving the same side uppermost, and Hogg thought that 'a more improper method of tillage cannot well be conceived, as much of the ground is missed, that of it which is ploughed is rather crushed to one side than turned over, and as two of the horses are obliged to go constantly on the tilled land, it is by these means rendered full as firm as before it was ploughed'.⁴ Extra hands frequently followed with spades to level the furrows and break the clods.

Most of these comments were made by outside observers. The truth of the matter is that the ploughs were well adapted for the kind of work they had to do. They were not suitable for stiff or stony ground, though the Caithness version had a pair of shares, one of which was unfeathered for use in such soils,⁵ like the share of the old Scotch plough. In the Northern Isles, however, they were mainly used on lighter or previously tilled soils, and since no ploughing was undertaken before spring, the harrowing action of the mould-strokers or twin mould-boards helped to break up the earth and produce a good tilth. It was for precisely this reason that they remained in use so long in Orkney alongside the two-stilted plough, for giving the last of three ploughings before a bere crop. As Table II shows, they ploughed to a depth of 3 to 4 in., and could deal with a quarter of an acre in a day, and 15 to 20 acres in a season.

Although this picturesque group of implements had to all intents and purposes become redundant by the first half of the nineteenth century, it was not until the twentieth century that they finally died out. More than one was photographed in use in Orkney in the 1890s (Pls. XLVI, XLVII) and at least one was still working in 1903.⁶ John Firth, writing in 1920, said he remembered two being made in Finstown,

¹ *O.S.A.*, VII (1793), 585-6; Hogg, J., *op. cit.*, 70.

³ Low, G., *op. cit.*, 56.

⁶ Henderson, J., *op. cit.*, 56-57.

² Hogg, J., *op. cit.*, 70.

⁴ Hogg, J., *op. cit.*, 70.

⁶ Marwick, G., *op. cit.*, 2.

TABLE IV
SURVIVING SINGLE-STILTED PLOUGHS AND ILLUSTRATIONS

Place of Origin	Where Preserved	Previous Illustrations	Illustrations of Other Ploughs (published)
<p>SHETLAND</p> <p>1. Dunrossness 1877</p> <p>2. From Lerwick Collection 1882</p> <p>3. Whalsey 1936</p>	<p>N.M.A.S.</p> <p>N.M.A.S.</p> <p>N.M.A.S.</p>	<p><i>P.S.A.S.</i>, xii (1877), 264; A. Mitchell, <i>Past in the Present</i>, Edinburgh (1880), 95; G. Goudie, <i>Celtic and Scand.</i> <i>Antiqs. of Shetland</i>, Edinburgh and London (1904), 291; N.M.A.S. <i>Short Guide to</i> <i>Scottish Antiqs.</i>, Edinburgh (1962), 43; <i>Arch. J.</i>, civ (1947), Pl. VI <i>Sc. Studies</i>, I (1957), 77</p> <p><i>Sc. Studies</i>, I (1957), 77</p>	<p>4. <i>O.S.A.</i>, v (1793), inset to frontispiece</p> <p>5. Hibbert, 1822, fig. 20</p>
<p>ORKNEY</p> <p>1</p> <p>2-4</p> <p>5</p> <p>6</p>	<p>Stromness Museum</p> <p>Tankerness House, Kirkwall</p> <p>Glasgow Museum & Art Gallery</p> <p>N.M.A.S.</p>	<p><i>Sc. Studies</i>, I (1957), 80</p>	<p>7. Wm. Aberdeen's plan, 1770 in <i>Proc.</i> <i>Ork. Ant. Soc. II</i> (1923-4), facing 52.</p> <p>8. J. Shirreff <i>Agric.</i> <i>Orkney</i>, London (1814), facing 51</p> <p>9. G. Marwick <i>Old</i> <i>Roman Plough</i>, Kirkwall (1936), Frontispiece</p> <p>10. J. Firth <i>Reminisc.</i> <i>Orkney Parish</i>, Stromness (1920), fig. 2 on Pl. facing 106</p>
<p>OUTER ISLES</p> <p>1. Islay</p>	<p>N.M.A.S.</p>	<p><i>Sc. Studies</i>, I (1957), 77</p>	<p>2. <i>Ealadhna Duthshasach</i> <i>na H-Alba, Scottish</i> <i>Home Industries</i>, Dingwall (1895),</p> <p>3. Dwelly, s.v. <i>Crann-</i> <i>nan gadd</i></p>

Orkney and that one had been used within the preceding fifty years by Thomas Cursiter on his farm at Thickbigging. In Shetland, Sir Arthur Mitchell saw one ploughing at Colinsbroch, Dunrossness, in 1864.¹ In Caithness, they were seen in the parish of Wick in 1841² though the establishment of a factory in Thurso in the late nineteenth century for making carts and ploughs had dealt single-stilted ploughs their quietus in most parts of Caithness. In Lewis, they are said to have been still working shortly before 1900 in the Barvas district.

III. SPADE, CAS CHROM, AND RISTLE

(1) *Spade*

The evidence for early spade cultivation in the Western Islands and Highlands is both specific and inferential. In the mid-sixteenth century, Monro mentioned four areas where the spade was in use: Taransay, where all the townships cultivated their land with it, except for as much as one horse plough would till (probably about 12 acres, on the Orkney analogy), and had an abundance of bere; Harris, which had 'tways mair of delvit nor of teillit land in it'; Berneray Beg, which produced yearly 'mair nor 200 bollis beir with delving only'; and Rona, where 'abundand of corn growis . . . be delving'.³ At the end of the same century there is a reference to corn land delved with spades in St Kilda,⁴ and in the 1690s Martin specified spade-cultivation in Bernera, North Uist (though ploughing was also common there), Skye, and the Isle of Altig.⁵ The inferential evidence is based on crop yields. The high seed/yield ratio shown in Table V is undoubtedly the result of the almost horticultural intensity of cultivation made possible by the spade (or by the *cas chrom*) on oat or bere land. The average yields from plough cultivation were very much less in other parts of Scotland. In seventeenth-century Galloway, bere returned 1:4-5, which was described as poor.⁶ Mackintosh of Borlum in 1729 gave the Scottish average as 1:4 for bere and 1:3 for oats.⁷ This corresponds to the average for the medieval period in Western Europe, which was about 1:3.5 for barley and 1:3 for oats.⁸ Even if these averages were calculated after the deduction of tithes, it is still apparent that spade cultivation gave returns that were three or more times greater than those resulting from plough cultivation.

It will be seen that the high yields are much more often of barley or bere than of oats. Bere required a fine tilth, produced in Lowland Scotland by three or more ploughings, so that spade cultivation suited it. The available evidence suggests that in the W. oats were generally cultivated by the plough on the sandy machars, and bere by the spade in lazy-beds. It is not possible to ascertain the relative amounts grown, but since the terms 'bere' and 'corn' are sometimes set in opposition to each other in the early sources, suggesting that the latter indicates oats as it does in Scots dialectal speech at the present day, then the frequent references to 'corn' crops in

¹ Mitchell, A., *The Past in the Present*, Edinburgh (1880), 94.

² *N.S.A.*, xv (1845), 148.

³ Munro, R., *op. cit.*, 80, 81, 86, 87-88.

⁴ *Anon. Descr. of the Isles of Scot. (c. 1577-95)*, in Skene, W. F., *Celtic Scot.*, III, Edinburgh (1880), 431.

⁵ Martin, M., *Descr. W. Islands of Scot.*, London (1703), 43, 53, 139, 140.

⁶ Symson, A., *Large Description of Galloway*, Edinburgh (1823), 73-74.

⁷ Mackintosh, E. W., *Essay on Ways and Means for Inclosing*, Edinburgh (1729), 59.

⁸ Slicher van Bath, B. H., *Agrarian History of Western Europe*, London (1903), 172.

these islands may indicate a greater acreage of oats (under the plough) than of bere. The oat crop was required not only for making meal, but also for making the liquors called usquebaugh (whisky), trestarig (thrice distilled), and usquebaugh-baul (four times distilled),¹ valuable as stimulants, as medicines, and for helping to pay the rent.

Lazy-beds and the Cas Dhireach. The *Old Statistical Account* and other documentary sources refer to cultivation by the *cas dhireach* or straight spade in Lewis and Harris, the Uists, Bernera, Rum, Skye, St Kilda, and the parishes of Farr and Assynt in Sutherland. In these areas, the characteristic cultivating technique involved the making of lazy-beds. In other areas of spade cultivation, different types of spades and different techniques were found.

The lazy-bed technique may have been known in Britain in Romano-British times.² In Scotland, a form of it is traceable in the Isles back to the sixteenth century, and the Gaelic term *feannagan taomadh* (= the poured-out flaying,³ first recorded in Lewis in the form *timiy* in the 1690s,⁴ is older than the now commonly used term *lazy bed*,⁵ which preserves the obsolete sense of the adjective *lazy* = 'fallow, untilled', with

TABLE V
YIELDS

<i>Place</i>	<i>Anonymous Descr.</i> <i>c. 1577-95</i>	<i>Martin c. 1690</i>	<i>Macdonald 1811</i>	<i>Implement</i>
Bernera		Barley 1:20-30; one grain could give 7, 10, 12, and 14 ears		Spade
Bernera			Barley 1:25 ⁶	Caschrom
Skye (1) Corchattachan		Barley 1:35; one grain could give 5 ears (marle used)		
(2) Near Kilmartin		Oats 1:20-30 (after 7 years fallow)		Spade
(3) Near Skerybreck Isle of Altig		Barley 1:100 Barley, 1 grain could give 5 ears		
Lewis Eigg Harris	Bere 1:16, 18, and 20 Oats 1:10-12	Barley, 1 grain could give 5 ears		Spade
South Uist		idem		

¹ Martin, M., *op. cit.*, 3.

² Clarke, J. G. D., *op. cit.*, 147, Pl. XIV.

³ Crawford, I., in *Sc. Studies*, vi (1962), 244.

⁴ Martin, M., *op. cit.*, 3.

⁵ First recorded in R. Maxwell, *Select Transactions of the Society of Improvers*, Edinburgh (1743), 159.

⁶ Macdonald, J., *Agric. Hebrides*, Edinburgh (1811), 154.

reference to the undisturbed original ground surface below the bed. In the mid-sixteenth century, Munro, talking of Lewis, said that: 'All is peitmosland at the sea coist, and the place quhair he wynis his peittis this yeir thair he sawis his beir the next yeir; efter that he guides it weill with sea ware.'¹

The winning (drying) of peats would naturally take place on a raised ridge or part of the peat bog where cuttings had left a piece high and dry, and it may well be that the later system of lazy-beds evolved here from an earlier custom of raising crops on the high parts left in the peat bogs by fuel-cutting. By the last quarter of the sixteenth century, at any rate, it is clear that cuttings were being deliberately made to leave well-drained ridges, since the *Anonymous Description* says of Mull that 'in mony pairtis thair of are great moses, and thay will cast ane fowssie or stank throw the ane pairt of the moss, quhairby the water may easier pass away, and teillis syne the remanent of the moss, sa far at the leist as becumis dry be vertue of the fowssie castin, and takis it that thair cast out of the fowssie and guidis the teillit earth thair-with, and thairon will grow the best beir in the Isles, of sic quantitie that I think shame to write it.'²

These two quotations illustrate three characteristic lazy-bed features – manuring with seaweed, the digging of trenches or ditches, and the throwing up of the upcast. The aim was to form a platform raised above the water-table on which crops could be grown. A ridge and furrow type of lazy-bed also appeared on soils other than peat, though not recorded till well through the eighteenth century. It was basically the spade-produced equivalent of the Lowland ridge and furrow, and was from time to time split down the middle (a process called *taomadh a broin*³) so that the ridge became the furrow, as in Lowland Scottish practice, though this feature is unlikely to have developed until the breakdown of the run rig system brought an end to the periodic re-allocation of the holdings of individuals in a township. At the present day, such beds move their own width one way or the other about every five years, the crofter turning them so far over each year.⁴

In Lowland sources, the earliest description of lazy-beds is in relation to the growing of potatoes. James Donaldson, who wrote the first treatise of any length on Scottish agriculture, recommended the making of 'Beds or Rigs' of about 8 ft. wide, with a furrow between 2 ft. wide by 2 ft. deep, for this new root crop.⁵ He was describing what he had seen elsewhere, possibly in Ireland. His suggestion that lazy-beds of this nature should be used as a means of reclaiming, cleaning, and draining rough land, old pasture, and wet soils bore fruit, as shown by a number of later writers.⁶ By the end of the eighteenth century the practice was being discontinued in the Lowlands as drill cultivation of potatoes developed and as land improvement by drainage went on. In the early nineteenth century, lazy-beds were being used for the planting of seedling trees,⁷ as they still are by the Forestry Commission.

¹ Munro, R., *op. cit.*, 86-87.

² Buchanan, *op. cit.*, 154.

³ *Anonymous Descr.*, *op. cit.*, 435.

⁴ Fraser Darling, F., *West Highland Survey*, Oxford (1955), 224.

⁵ Donaldson, J., *Husbandry Anatomized*, Edinburgh (1697), 118-19.

⁶ e.g. Belsches, R., *Agric. Stirling*, Edinburgh (1796), 31-32; Robertson, J., *Agric. Perth*, Perth (1799), 172.

⁷ Robertson, G., *Agric. Kincardine*, London (1813), 304.

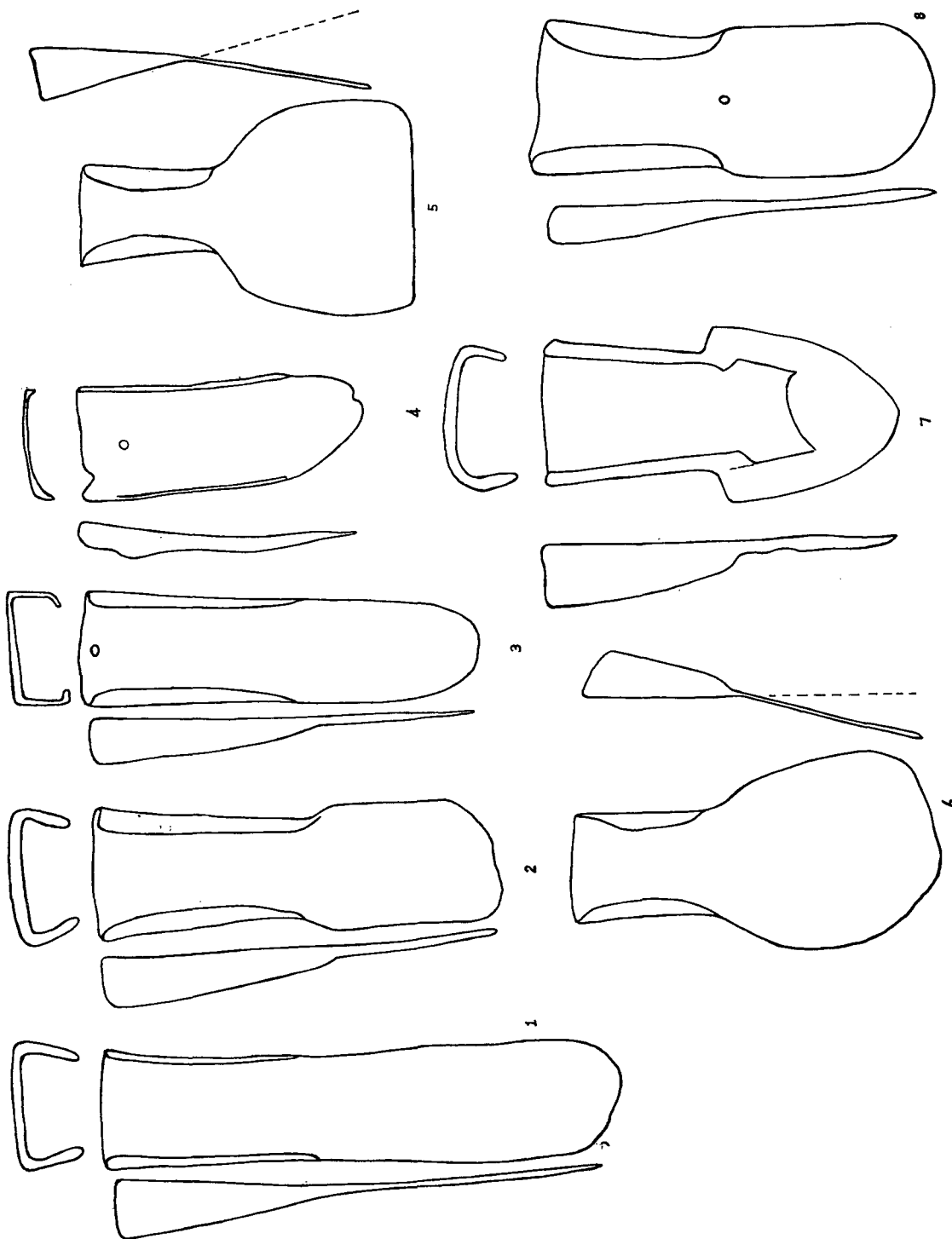

FIG. 14. The blades of delving spades and cas chroms in the N.M.A.S.: 1-4. *Cas dthreach*; 5-6. Shetland delving spades; 7-8. *Cas chrom*

In the Lowlands, therefore, the lazy-bed technique resulted from the introduction of the potato crop and probably had an effective duration of little over half a century. Its use was probably sporadic and unsystematic. In the Highlands and Islands, however, it has been going on for over 500 years as an integral and essential part of the agrarian system, and has given a particular form to the associated implements of cultivation.

For both the 'platform' and the 'ridge and furrow' types of lazy-beds,¹ the method of making was the same. The bed or ridge was marked out, about 6 ft. wide, or more according to district, and seaweed spread on it as manure.² In Harris it was said that 200 large creels of sea-ware were needed to produce a boll of barley, or 12-14 barrels of potatoes.³ Turves were then cut so as to leave a ditch varying from 2 to over 6 ft. wide at each side of the ridge, and were laid grassy side down above the seaweed. Cutting was done with the narrow-bladed *cas dhireach*, and an assistant lifted each turf and laid it grassy side down on the ridge.⁴ This latter point is important because it emphasises that the *cas-dhireach* was adapted for cutting rather than lifting. Like the Irish spade, it 'is not a digging implement; it is essentially a ridge-maker or hand-plough, adapted to the business of undercutting and turning the sod'.⁵ Examples from the W. of Scotland have straight blades (fig. 14: 1-4), and the shaft usually swells into a heel above the socket like the Irish *loy*, though not so noticeably, so that leverage can be more readily applied in turning the sod. In the Shetland spade, the blade itself is bent forward at an angle to provide leverage (fig. 14: 5-6). It is

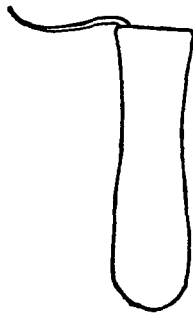

FIG. 15. The blade of a Manx spade, after B. R. S. Megaw. The width, $3\frac{1}{2}$ in., is close to that of the blade of the *cas dhireach*.

associated with cultivation on the flat, whereas the *cas dhireach* is intimately associated with raised lazy-beds. The formal development of the latter must have been dictated by the requirements of lazy-bed cultivation.

Heron has described the *cas dhireach* as a 'lugged' spade,⁶ and another writer has compared it to the 'lugged spade' of the S. of Scotland.⁷ Since the reference is to digging spades, the term must indicate the wooden peg or foot-rest by which it was

¹ These terms have been adopted for convenience in reference to the fixed lazy-beds, mainly on peat, and to the type found on wet, but not necessarily peaty soil that is treated like the Lowland ridge and furrow, but between the two extremes is a broad area where narrow definition is impossible.

² See Fraser Darling, F., *Crofting Agriculture*, Edinburgh (1945), Pl. II; Evans, E. E., *Irish Folk Ways*, London (1957), 142, 145.

³ Heron, R., *General View of the Hebrides*, Edinburgh (1794), 17-18.

⁴ Buchanan, op. cit., 153-4; *O.S.A.*, x (1794), 352-3.

⁵ Evans, E. E., op. cit., 128.

⁶ Heron, R., op. cit., 17.

⁷ *O.S.A.*, x (1794), 352-3.

thrust into the earth, rather than the wing or feather characteristic of a peat-spade blade, as the *Scottish National Dictionary* suggests. It is of considerable interest that a spade of *cas dhireach* type should thus appear to have been used in the S. of Scotland, where the blades or shares of Romano-British date were found. Since the *cas dhireach* was a turf cutting implement, it is likely that the 'lugged spade' performed a similar function, and may have been used, like the Manx spade (recorded from the fifteenth century) for making dykes of 'feal' or sods (fig. 15).¹

Whether or not the 'foot-spade' frequently referred to in Scottish pre-1700 sources is the same implement is uncertain, though it was also used for 'casting fail' (turf cutting), and the *Forbes Baron Court Book* records an act made in 1671 'anent castin of fail eather with foot spadis or flachter spad . . . vithtin meadow gras, hauchis or any pairt of haining of thair severall possessions'.² Any infringement involved a £10 fine for the foot-spade, and a £5 fine for the flachter-spade (= 'flaying', or turf spade), suggesting that the foot-spade was twice as efficient, or at least capable of doing more damage by its greater power of penetration. In 1516 a foot-spade cost 10d, as against a peat spade at 7d.³

The second main area of intensive spade cultivation was Shetland. Prior to the development of the fishing industry in the eighteenth century, the Shetlander was dependent more on the plough than the spade (though this is not to say that the peasantry did not cultivate their holdings with the spade as well), but with the subdivision of holdings brought about by the proprietors' requirements in man-power for hand-line fishing, paralleling to some extent what happened in the Hebrides as a result of the kelp industry, it was no longer practical for a single crofter to work a plough and maintain the team of four normally required for it.⁴ By the end of the eighteenth century the new pattern of cultivation had become firmly established, but the change was still within memory. The minister of Bressay, Burra and Quarff said, rather sorrowfully, 'the farms are now so small, that the people cannot afford to keep ploughs'.⁵ In Dunrossness, five to seven people, using spades of a light kind, could turn as much as a Scotch plough with eight to ten oxen.⁶ In Northmaven the number of ploughs had been decreasing for many years,⁷ and the minister of Unst, in making the same comment, specifically blamed the fishing.⁸ In the parishes of Lerwick and Mid and South Yell, almost all cultivation was by the spade.⁹ In 1814, nine-tenths of the country was estimated to be under the spade.¹⁰ The picture was a very different one in Orkney, where only the small island of Eday was entirely cultivated by the spade.¹¹ The same was true of Stroma,¹² an island in the Pentland Firth, forming part of Caithness.

The lightness of this 'dellin' spade, and its short, broad blade, angled forward

¹ Megaw, B. R. S., *The 'Manks Spade'* in *Jnl. Manx Museum*, iv (1939), 165-7, Pl. 174.

² *Misc. Sc. Hist. Soc.*, Edinburgh (1919), III, 284-5.

³ *Family of Rose of Kilravock* (S.C. 1848), 189.

⁴ cf. Donaldson, G., *Shetland Life*, Edinburgh (1958), 35-36, and review by Megaw, B. R. S., in *Scottish Historical Review*, LXXXIX (1960), 63-65.

⁵ *O.S.A.*, x (1794), 196.

⁶ *O.S.A.*, vii (1793), 393.

⁷ *O.S.A.*, xii (1794), 355.

⁸ *O.S.A.*, v (1793), 192.

⁹ *O.S.A.*, III (1792), 418; I (1791), 574.

¹⁰ Shirreff, J., *op. cit.*, 36.

¹¹ *O.S.A.*, xv (1795), 403.

¹² Pennant, T., *Tour in Scotland 1769*, Chester (1771), 154.

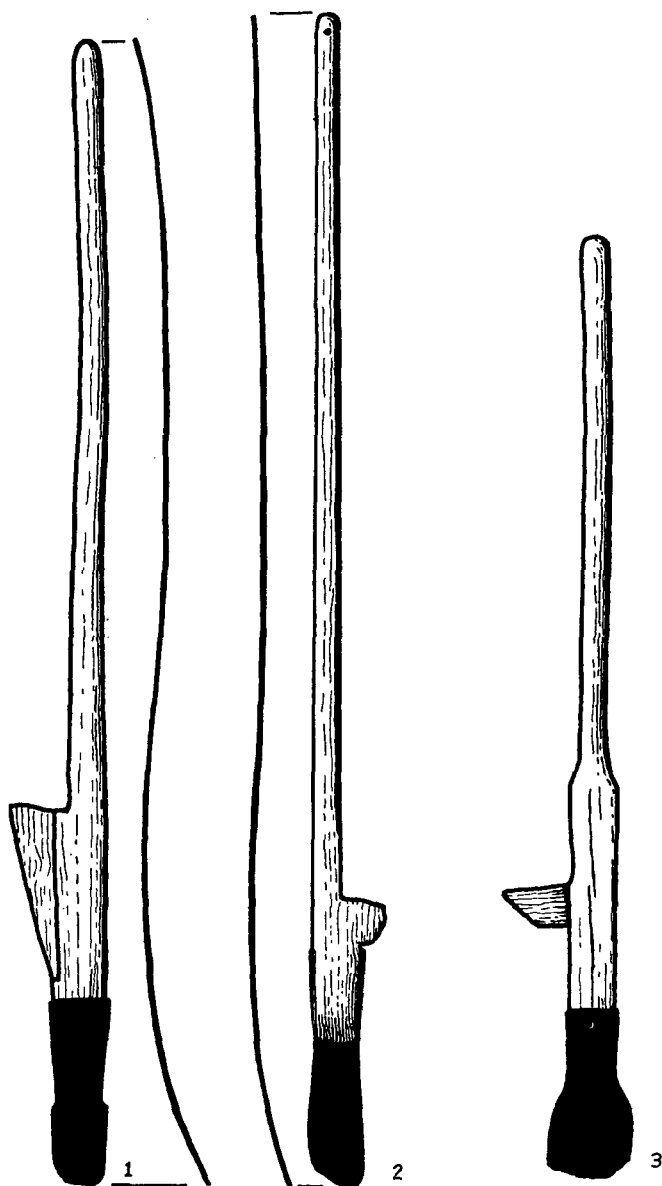

FIG. 16. 1. A *cas dhireach* (cf. fig. 14:2); 2. A *cas dhireach* (cf. fig. 14:1);
3. A Shetland delving spade

for leverage, like the blades of many of the Irish spade types, make it quite unlike the Highland *cas dhireach* (fig. 16: 1-2). The earliest illustration of an 'Orkney spade' is by William Aberdeen, about 1770 (fig. 17). The blade is oval in shape, and the back of the shaft swells out to form an angular heel in the same way as the *cas dhireach* shaft. The present day Orkney 'moor-spade' or 'pone-spade' for turf cutting has a

similarly sturdy heel and foot-peg, and since in Shetland the older style of 'dellin'-spade' had rounded corners (fig. 14: 6), it may be that Aberdeen's illustration represents an earlier form of delving spade. According to Aberdeen's manuscript note, it was composed of 'a piece of iron, about 9 inches long, . . . made thin and five inches broad at one end, and at the other a square socket into which is fixed

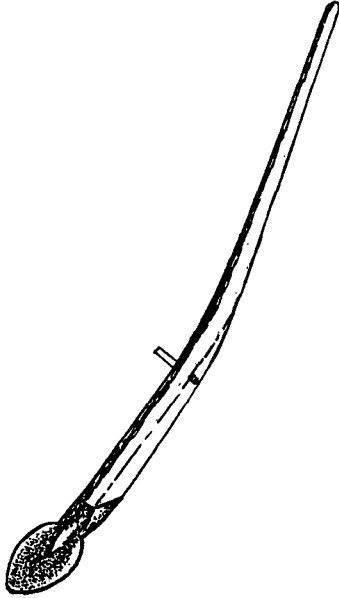

FIG. 17. An Orkney spade, after Aberdeen, *c.* 1770. By courtesy of E. Macgillivray, Librarian, Kirkwall

a crooked piece of wood. It is so made as not to run above three inches below the surface.'

There is no doubt about the exact function of the spade in the next illustration (fig. 18), in 1814, for it is the same as the Shetland delving-spade of the present day. Just as it differs from the *cas dhireach* in shape and size, so does it differ in its method of use. It is, characteristically, an implement of team cultivation. In Shetland team delving continued well into the present century. The members of the team, normally three or four in number (Pl. XLVIII, 1), sometimes up to five or six¹, stood side by side, keeping their spades 6 to 8 in. apart, and thrust them in by pressing with their feet on the projecting heel till the metal of the blades was almost hidden. Then, all together, they loosened a long sod or 'peat', lifted it a fraction, and turned it right over. A three-man team could cut a sod up to 2 ft. long by 8 to 12 in. wide by 4 to 6 in. deep. The delver on the left had the 'fore-spade', and set the pace as they worked from right to left along a furrow or 'geng'.² Most of the fields or rigs are on

¹ *O.S.A.*, VII (1793), 393.

² Jamieson, P., *Letters from Shetland*, Lerwick (1949), 193-5.

a slope and the team always started at the bottom and worked uphill.¹ The result was that as each sod was turned over into the trench left by the one removed from immediately below it, the cultivated surface gradually moved downhill, and since the first furrow cut by the team was usually thrown up on undug land, it formed a little bank, against which the earth accumulated. According to the minister of Northmavine 'at the bottom of every plot of ground or ridge, the earth, and always the best, has accumulated to a considerable depth'.² Jamieson described how earth was wheeled in barrows or carried up in baskets on the back to the barer parts each

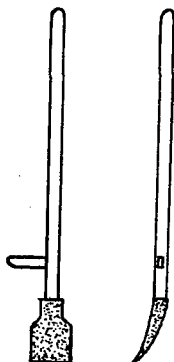

FIG. 18
A delving spade of
the Northern Isles,
after Shirreff, 1814

year, and he commented, in resigned fashion, that 'this seemed to make little difference'.

Such a method of cultivation could and did produce squarish or rectangular fields of irregular lynchetted appearance (Pl. XLVIII, 2) on slopes. It has often been assumed by archaeologists that the 'Celtic' fields of Southern England and of Jutland³ must have been formed by the action of a plough, but the Shetland practice as described shows that the spade is equally capable of building up lynchets and forming similar fields. Indeed, it is remarkable how similar the furrow produced by a delving team is in appearance to that produced by a plough. Teamwork, in fact, makes the spade function almost exactly as a plough (Pl. XLVIII, 1). It would be rash to assume from this that the 'Celtic' fields were made as a result of spade-cultivation, but in view of the known early occurrence of spades in Bronze Age Britain, it is a possibility that must at least be borne in mind.

Delving in teams was not restricted to Shetland, though in the Highlands, records of it are scanty. Teams of three were working in the 1940s at Smearisary in Moidart,⁴ and Fraser Darling refers to the old team of four, which, he said, could turn a third of an acre a day, of very high quality.⁵ The most southerly known occurrence of team-delving is in the Luss and Arrochar area of Dunbartonshire in the late eight-

¹ *N.S.A.*, xv (1845), 77-78.

² *N.S.A.*, xv (1845).

³ For diagrammatic representations see Bowen, H. C., *op. cit.*, 25.

⁴ Whitaker, I., in *Sc. Studies*, III (1959), 176, footnote; O'Malley, R., *One Horse Farm*, London (1948), 22.

⁵ Fraser Darling, F., *West Highland Survey*, Oxford (1955), 224.

eenth century. Here, eight or ten people would work together, moving backwards uphill, and turning over a furrow 18 or 20 ft. long by 8 or 10 in. broad by 9 or 10 in. deep in one movement. The proportions are noticeably similar to those of a good-sized plough furrow.¹ There is no indication here of the area dug in relation to the



FIG. 19
The delving spade
of Dunbartonshire,
after Ure, 1793

area ploughed, but in Ardnamurchan and Sunart in Argyll, as late as 1837, 1260 acres of arable were dug and 1504 ploughed² on the estate.

The spade used in Luss and Arrochar was illustrated by Ure³ (fig. 19), and is unlike both the *cas dhireach* and the Shetland spade. It has a one piece blade and shaft, with the blade set asymmetrically so that the top of one side of the blade acts as a foot-rest. The lower half of the blade is shod with iron. In Arran, a similar type was used. It was 'an angular piece of wood, shod with three or four inches of iron at its point, and having a long handle on its right side, dressed from the same piece of wood. The angle projected from the handle, towards the left, serves for pressing it down with the foot.'⁴ It was said to be good in stony ground, and sometimes served in place of a hand-hoe for planting, cleaning and digging potatoes. This was

¹ Ure, D., *Agric. Dumbarton*, London (1794), 39-40.

² Calculated from the original estate plans in the Scottish Record Office. Bald's M.S. map of 1806 maps both regions, distinguishing areas of spade and plough cultivation.

³ Ure, op. cit., 39; also in Gomme, G. L., *The Village Community*, London (1890), 279.

⁴ Headrick, J., *View of Arran*, Edinburgh (1807), 316-17.

evidently a survival of what, to judge by manuscript illustrations, was a common medieval type, and may well be the one described as a 'foot-spade' in sixteenth-seventeenth century Scottish sources.

Imported iron spades were coming in from southern markets in the first half of the eighteenth century, though at first only on the lands of improving lairds like Grant of Monymusk, who was getting 'steel spads' and 'shod shovels' from Leith in 1735.¹ In Caithness, about 1788, fir shovels were imported from Norway along with fir planks and deal in exchange for cargoes of oatmeal. The countryfolk bought the shovels at 4d to 6d each, had them shod with iron, and 'they then served the purpose of the present iron spade at much less expense; but they were not so handy or effectual in farm-work'.² By the end of the eighteenth century, it appears from the scattered references that iron spades of the conventional present-day variety were known and used in most parts of Scotland. They have so far failed to oust the Shetland spade completely. The *cas dhireach* of the North Western Islands and Highlands, and the asymmetrical spade of Dunbarton and Bute, were displaced by them in the course of the nineteenth century.

(2) *Cas Chrom*

The first recorded use of the term 'crooked spade' was supplied by Martin, in 1698, with reference to St Kilda where 'they use no Plough but a kind of crooked Spade' for cultivating bere, and a small quantity of oats. A less orthodox use of it involved one Roderick, who claimed to be sent to the St Kildans by St John the Baptist with new revelations and discoveries, and 'commanded that every Family should Slay a Sheep upon the Threshold of their Doors, but a Knife must not so much as touch it, he would have them only make use of their Crooked Spades for their Instruments to kill them with'. This, said Martin, pointing the obvious, was most improper, since the edge was almost half an inch thick.³

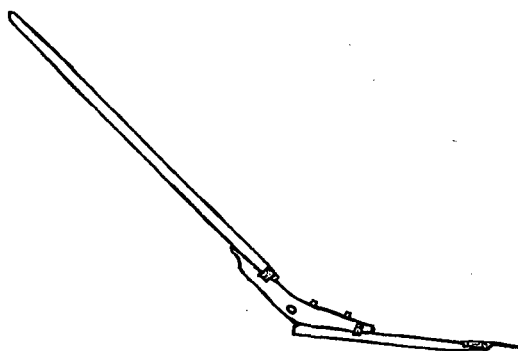

FIG. 20. A *cas chrom* from Strome Ferry. See Table VI.
The foot-peg is missing

¹ Hamilton, H. (ed.), *An Aberdeenshire Estate 1735-50* (Third Spalding Club) (1946), 25.

² Henderson, J., *Agric. Caithness*, London (1812), 66.

³ Martin, M., *Voyage to St Kilda*, London (1698), 28, 140.

On the face of it, this would seem to be a clear enough reference to the *cas chrom*, which in the eighteenth-century literature is commonly translated into English as the 'crooked' spade. In his earlier book, however, Martin spoke of the 'foot spade' in St Kilda.¹ In the sixteenth century the St Kildans delved their corn land with spades.² In 1765 the spade was again referred to as the cultivating implement of the island.³ In the nineteenth century, the *cas chrom* was referred to in St Kilda by its Gaelic name for the first time.⁴ Setting aside Martin, the story would appear to be that spade-cultivation was the rule in St Kilda till about 1830, when, as a result of the Rev. Neil Mackenzie's reforming zeal the settlements were laid out in the form of a linear village, with fields above and below the houses in long strips on which the *cas chrom* could have been effectively used. If this is correct, Martin's statement has to be explained away, and it is possible that by 'a kind of crooked spade' he meant the *cas dhireach*, which, as described earlier, has a form broadly resembling the Irish *loy*, with a swelling of the heel at the back that might justify its being called 'crooked'. His use of the term 'foot spade' which in seventeenth-century Scotland referred to a delving spade, would then cause no problem. The earliest definite evidence for the *cas chrom*, therefore, must still be held to date from the eighteenth century, since Martin's remarks can be interpreted in two ways.

Eighteenth- and nineteenth-century sources show that in its distribution, the *cas chrom* was confined to the rocky districts of the NW. Highlands and Islands. It occurred in Lewis (Lochs, Uig, Barvas, Stornoway), Harris, Bernera, North and South Uist, Barra, Skye (Snizort, Kilmuir, Sleat, Strath, Portree, Duirinish, Soay, Bracadale), Raasay, South Rona, Sutherland (Eddrachillis, Assynt, Durness, Tongue), Ross-shire (Glenshiel, Lochcarron, Applecross), and Mull (Kilfinichen and Kilvicheon, Bernera), and Jura. There is an example from Islay in the National Museum. Stewart's reference to its eighteenth-century use in the rougher parts of the parish of Fortingall, Perthshire, is unsupported by any other evidence for it in this area and is probably inaccurate.⁵ It was, therefore, more or less co-extensive with the *cas dhireach* (fig. 8).

Although it was sometimes used in cultivating the surface of lazy-beds, and in draining the side furrows,⁶ it normally functioned on the flat. Six or eight men were often seen at work with it together, and one man could turn two to four times as much ground with it in a day as with the spade.⁷ Movement was uphill, and in recent practice individuals would work across the rig, in the manner of spade delving,⁸ instead of moving steadily backwards along a single furrow.

Just as the form of the *cas dhireach* seems to have been dictated by the lazy-bed method of cultivation, so does the form of the *cas chrom* by the rocky terrain in which it characteristically worked. Similar developments are found in other parts of the

¹ Martin, M., *W. Islands*, London (1703), 286.

² *Anon. Descr.*, op. cit., 431.

³ Macaulay, K., *Hist. St Kilda*, Dublin (1765), 31-32.

⁴ Mackenzie, J. B., *An Episode in the Life of the Rev. Neil Mackenzie, 1829-1843*, privately printed (1911).

⁵ Stewart, A., *A Highland Parish*, Glasgow (1928), 166, 177.

⁶ *O.S.A.*, x (1794), 354; *N.S.A.*, xiv (1845), 154; Macdonald, op. cit., 151-6.

⁷ *O.S.A.*, vi (1793), 288; Walker, J., *Econ. Hist. Hebr.*, Edinburgh 1, (1812), 126-7.

⁸ I am indebted to A. F. Gray, F.S.A. SCOT., for this information.

world, such as the 'krokspade' or 'nabbespade' of Norway,¹ and examples are also known from Japan.²

In form it was, according to a description from Eddrachillis, 'a crooked piece of wood, the lower end somewhat thick, about 2½ ft. in length, pretty straight, and armed at the end with iron, made thin and square to cut the earth. . . . The shaft above the crook is pretty straight, being six feet long, and tapering upwards to the end . . . ; just below the crook or angle, which is an obtuse one, there must be a hole, wherein a strong peg must be fixed, for the workman's right foot, in order to push the instrument into the earth.'³ In Gaelic, the foot-peg was called the *sgonnan*, and the iron blade the *ceap* or *ceaba*.⁴ The description here clearly refers to a *cas chrom* with the head and shaft in one piece, like the 1774 illustration in John Home's *Survey of Assynt* (Pl. XLIX, 1), and like two examples in the Highland Folk Museum at Kingussie, one of which came from under several feet of peat. The majority, however, are composites with a separate head and shaft, and sometimes a third piece at the crook or heel, joined together by iron bands and nails (fig. 20; Pl. XLIX, 2). The foot-peg is invariably set in the thickness of the heel. Some were used by women since the minister of Stornoway thought it 'a disgrace to see women working with it',⁵ and in Barvas in the mid-nineteenth century it was going out as a woman's tool.⁶ Presumably the smaller sizes in Table VI were more suitable for female workers than the Eddrachillis size, which is above average.

TABLE VI
CAS CHROM DIMENSIONS

Place	Source	Museum No.	Shaft	Head
Strome Ferry	—	N.M.A.S.; MP 206	4 ft. 11 in.	1 ft. 11½ in.
Not known	—	N.M.A.S.; MP 282	5 ft.	2 ft. 0½ in.
Islay	—	N.M.A.S.; MP 389	5 ft. 4½ in.	2 ft. 2 in.
Eddrachillis	<i>O.S.A.</i> , vi (1793), 288-9	—	6 ft.	2 ft. 6 in.
Duirinish, Skye	<i>N.S.A.</i> , xiv (1845), 350	—	5 ft.	2 ft.-3 ft.
—	J. L. Buchanan, <i>Travels</i> (1793), 153	—	6 ft.	4 ft. [sic]
Berneria, Harris	J. Macdonald, <i>Agric. Hebrides</i> (1811), 151-6	—	5 ft. 9 in.	2 ft. 9 in.- 2 ft. 10 in.
Assynt, Eddrachillis	J. Henderson, <i>Agric. Sutherland</i> (1812), 178	—	5 ft.	2 ft.
Durness, Tongue				

A worker using a *cas chrom* moved backwards. He thrust the head into the ground by pressing on the peg with his right foot, and, having driven it 'far enough

¹ Erixon, S., *Lantbruket under Historisk Tid* in *Nordisk Kultur*, xiii, 85; Valen-Sendstad, F., *Norske Landbruksredskaper*, Lillehammer (1964), 32, fig. 2.

² Kothe, H., in *Ethnographische - Archäologische Forschungen* (1953), 1, 60, 88.

³ *O.S.A.*, vi (1793), 288-9.

⁴ e.g. *N.S.A.*, xiv (1845), 278-9, 350; McDonald, A., *Gaelic Words from South Uist and Eriskay*, Dublin (1958), *s.v.*

⁵ *N.S.A.*, xiv (1845), 131.

⁶ *N.S.A.*, xiv (1845), 148.

into the earth with one bend of his body, he raises the clod by the iron headed part of his instrument, making use of the heel, or hind part of the head, as a fulcrum, in so doing, turns it over always towards the left hand; and then proceeds to push for another clod in the same form'.¹

Besides turning over the soil, its form made it a powerful lever, as Johnson noted in Skye in 1775,² capable of clearing stones weighing up to 200 lb.,³ which the ordinary spade could not do. This power of leverage is, in fact, the outstanding characteristic of the *cas chrom*, and suggests that the implement was developed in rocky districts where this was a prime necessity. As previously noted, the *cas dhireach* has a marked heel clearly intended to increase the leverage (the blade being straight), and it only needs the shaft to be bent at an angle to the head for an embryonic *cas chrom* to be produced. The roughly similar distribution of the two implements in Scotland tends to support the idea of a typological sequence, *cas dhireach* whence *cas chrom*,⁴ brought about in answer to local conditions of a particular nature. In addition, there is a marked similarity between the shares of the two implements. One writer said the *cas chrom* blade was 'in the shape of a narrow Irish spade, about five inches broad'.⁵ The blade might also be 'triangular, resembling that used for casting turf'.⁶ This form was preferred in stony ground.

If this suggestion about the development of the *cas chrom* is accepted, an attempt may be made to date it. Sixteenth-century writers refer to spades without qualifying the term by some such adjective as 'crooked'. It is hard to believe that an implement as distinctive as the *cas chrom* would be included under the generic term 'spade', and the possibility arises that it did not then exist. The ambiguity of Martin's statements in the 1690s may indicate that the process of change had begun; that a spade like fig. 16: 2, resembling the one-eared spade of County Kerry, and truly a straight spade, was developing into a spade like fig. 16: 1, resembling the Irish *loy*, and requiring only a little more curvature of the shaft to become a *cas chrom*. It is significant that like the spade, the apparently earliest *cas chroms* were made from one piece of wood. The rise to fame of the *cas chrom* in the eighteenth century must then be due to the spread of potatoes as a crop that would in itself provide a means of subsistence, and to the development of the kelp industry which prevented the spending of time on the cultivation of crops,⁷ necessitating the use of an implement that worked faster than a spade. The evolution of the *cas chrom*, in areas where the ground was too rocky and shallow or too boggy for a horse drawn plough, then appears as a response to the same kind of superimposed economic conditions that gave rise to the development of the delving team in Shetland and elsewhere. In each case, poverty or soil conditions or economic pressure prohibited the use of animals, and the people had to carry on their cultivation by hand and by foot. The *cas chrom*, moving steadily backwards, turned in effect, albeit more slowly, a plough furrow, and a team of delvers did precisely the same. Indeed, if the delving teams had not

¹ *O.S.A.*, vi (1793), 288-9.

² Johnson, S., *Journey to the Western Islands*, Glasgow (1817), 119.

³ Macdonald, J., *op. cit.*, 153.

⁴ Campbell, A., has made a similar suggestion in *Folk Liv.*, viii (1944), 234.

⁵ Henderson, J., *op. cit.*, 57.

⁶ Robertson, J., *Agric. Inv.*, London (1808), 102-3.

⁷ See Handley, J. E., *Scottish Farming in the Eighteenth Century*, London (1853), 181 ff.

been present in the photograph from Fair Isle (Pl. XLVIII, 1), it would have been impossible to tell that the furrows had not been made by the plough.

(3) *The Ristle*

The *ristle* plough was an implement used in conjunction with the plough and sometimes the *cas chrom*. Its function was to cut a slit in the ground so that the plough or *cas chrom* would not be hindered by tough roots or a strong sward. In design, it may be regarded simply as a plough coulter mounted by itself in a beam. It was drawn along by one or two horses according to the nature of the terrain, and usually

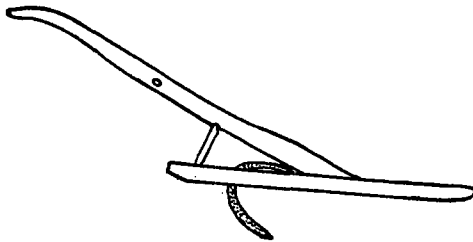

FIG. 21. A *ristle* from North Uist in the N.M.A.S. (PAA 5)

had a single stilt, though a two-stilted version was used in Tiree.¹ Since the *ristle* plough might require two men and two horses, its use along with a plough requiring two men and four or even five horses² as in Coll and Tiree meant a heavy cost in man and animal power that could only be met by small scale farmers as long as they could co-operate with each other under the old joint-farm system.

The records show a remarkably limited distribution for the *ristle* (fig. 8). It was first heard of in North Uist in the late seventeenth century, drawn by one or by two horses, facilitating the work of both the plough and the *cas chrom*.³ In the eighteenth and nineteenth centuries, it was used in Coll and Tiree, Harris, the Uists and Eriskay.⁴ It apparently remained in use till about the middle of the nineteenth century, when a small number was still at work in South Uist,⁵ and the example in the National Museum (fig. 21) was used in North Uist after 1850.⁶ It undoubtedly speeded up the amount of ploughing that could be done with the home-made implements available to the tenants, and with its help a group of ten to twelve men could turn an acre in a day, pulverising the soil as well as with 'two ordinary Hebridian ploughs'.⁷ As an aid to the plough it is known in various parts of Europe – Scandinavia, the Iberian peninsula, the area of the Alps, and so on.⁸

The Gaelic name *risteal* or *crann ruslaidh* is Norse in origin, cognate with Nor-

¹ *O.S.A.*, x (1794), 412.

² Martin, M., *W. Islands*, Glasgow (1881), 53.

³ Walker, J., in *Sc. Hist. Rev.*, xix (1921-2), 43-44, in *Trans. Gael Soc. Inv.*, xxiv, 120-38, and in *Econ. Hist. Hebr.*, Edinburgh (1812), 1, 124-5; Heron, R., *op. cit.*, 14, 40.

⁴ *N.S.A.*, xiv (1845), 191.

⁵ Beveridge, E., *South Uist*, Edinburgh (1911), 314.

⁶ Macdonald, J., *op. cit.*, 156-7; see also Jirlow and Whitaker, *op. cit.*, 80.

⁷ e.g. Leser, P., *op. cit.*, 171, 182, 302-3; Jirlow and Wahlberg in *Skytteanska Samfundets Handlingar*, 1, 73; Dias, J., in *Laos*, 1, 131; Erixon, S., *op. cit.*, 103.

wegian *ristel*, Swedish *rist*, Old Norse *ristell*, suggesting the direction from which this implement came to Scotland. Since its characteristic use is before a plough – it may indeed be regarded as a separable part of a plough – it is all the more surprising that no record of its use appears in Shetland, Orkney or Caithness, where cultivation by the plough was intensive. Its distribution as known at present represents a survival in the main oat producing areas of the Western Isles and suggests an association with the rectangular-framed rather than with the single-stilted plough.

*The Society is indebted to the Council for British Archaeology
for a grant towards the cost of publishing this paper*



1. The Lochmaben plough beam. *By permission of the Dumfries Burgh Museum*



2. The tip of an iron bar share (No. 09026) from Silchester.
From the Silchester Collection, by permission of Reading Museum and Art Gallery and His Grace the Duke of Wellington

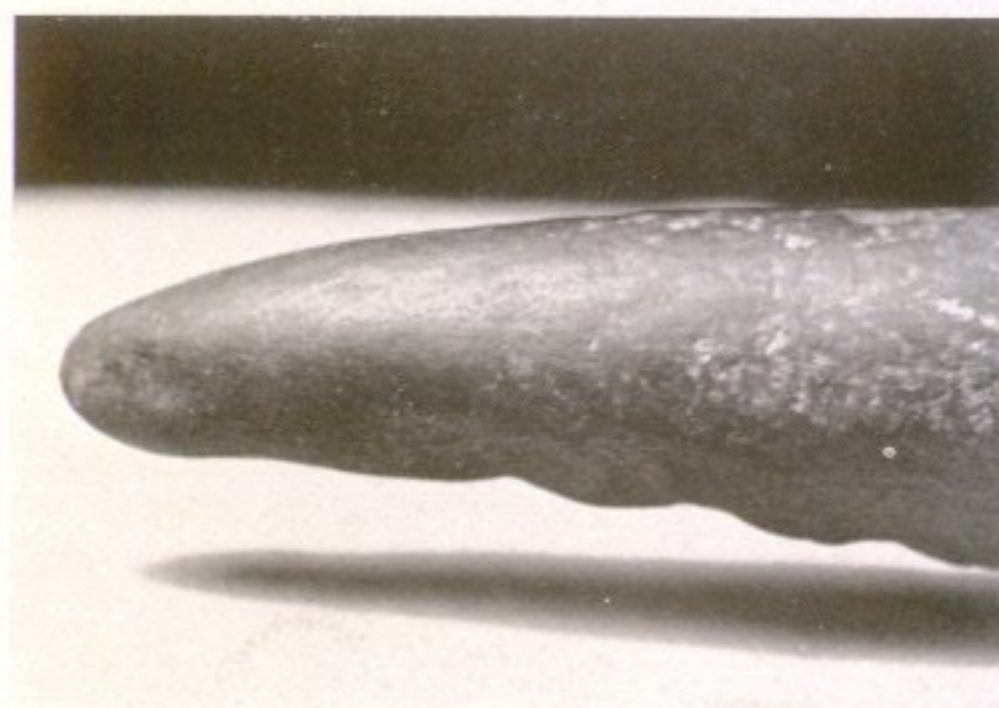

3. The tip of a stone share (AC 17) from Walls, Shetland

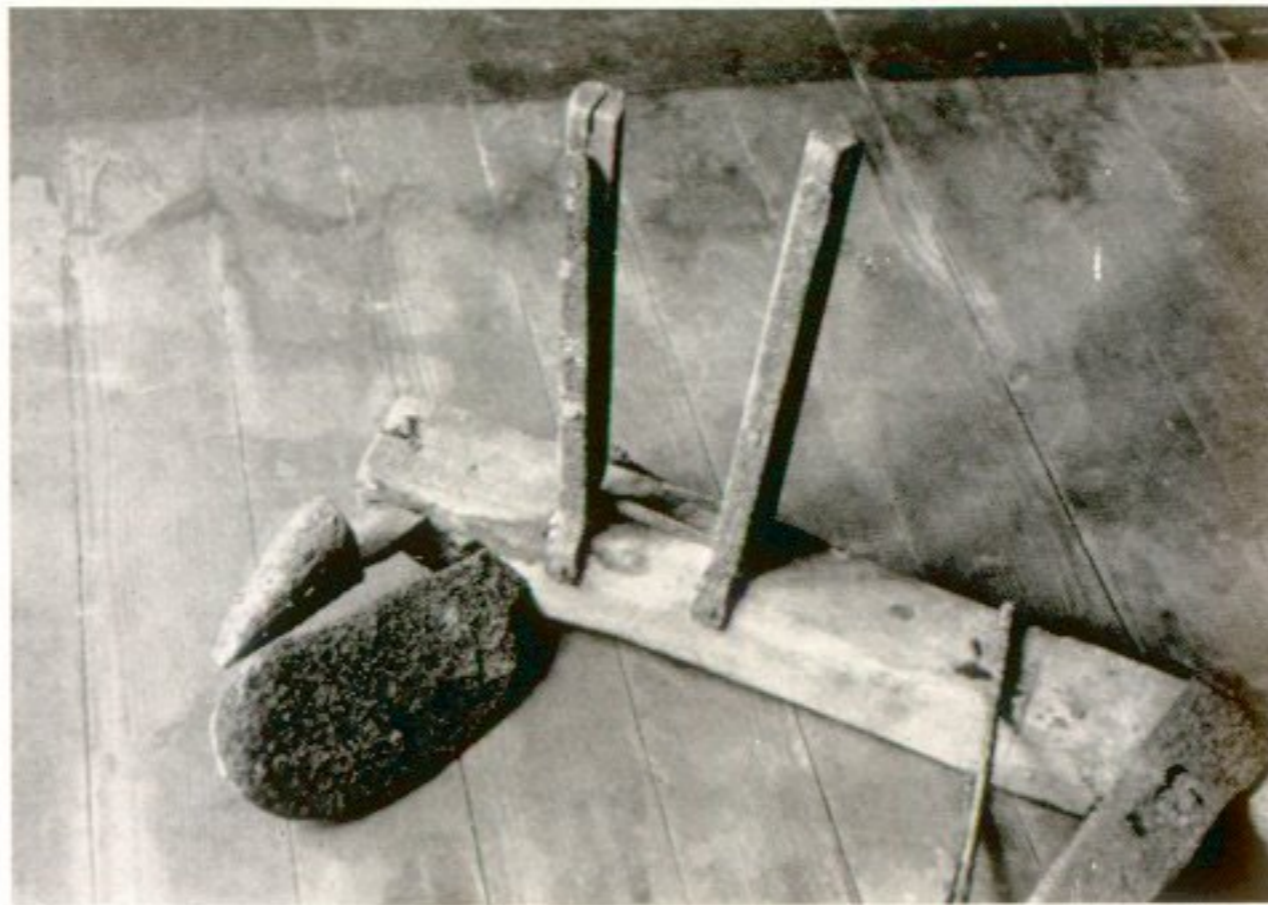

1. The iron-faced mould-strokers, the broad coultre in an angled mortice, and the small, pointed oval share (fig. 12:3) of a plough in Tankerness House, Kirkwall, Orkney

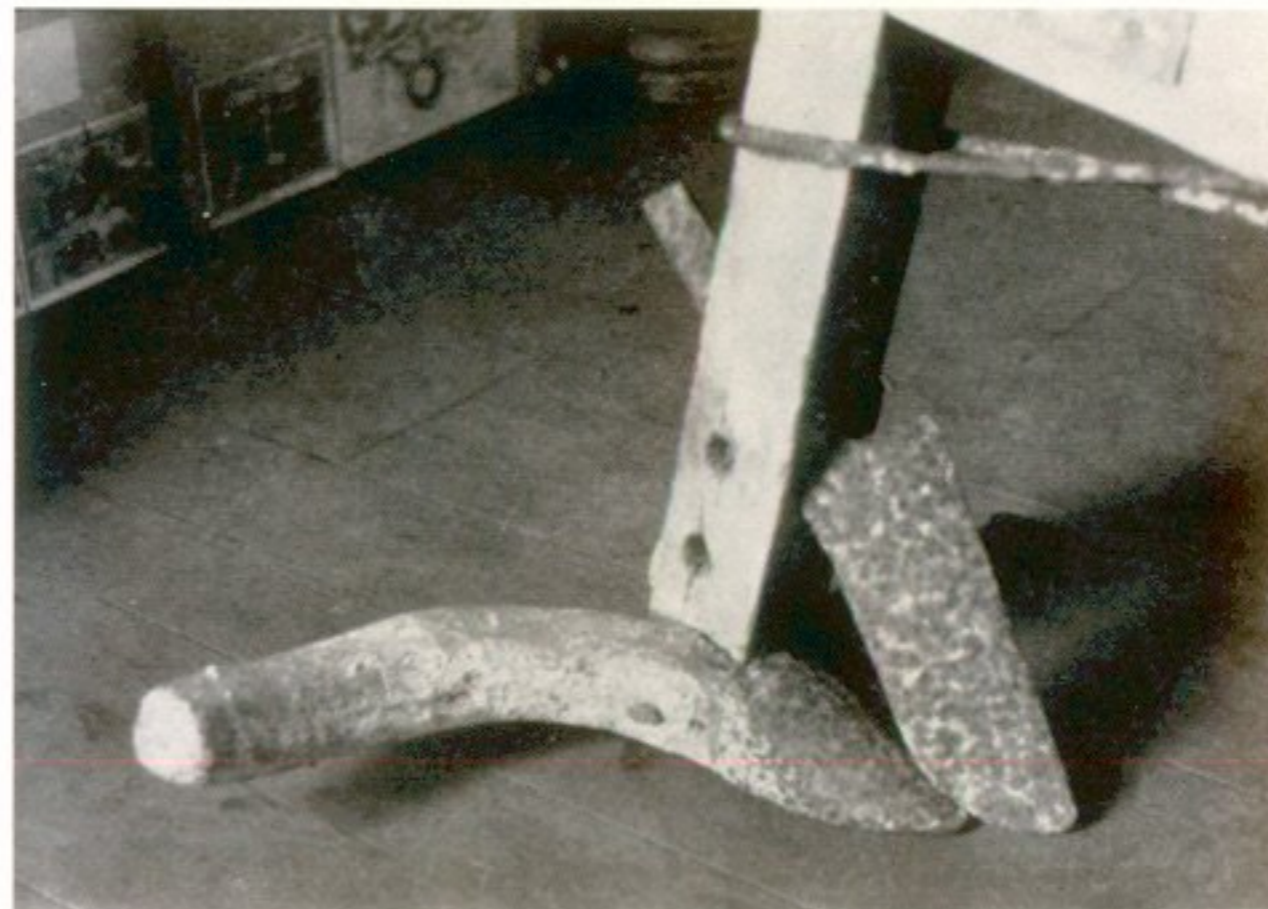

2. The *ear-sky*, angled coultre, and small, pointed oval share (fig. 12:3) of a plough in Tankerness House



3. The *mercal pin* and front of the *ear-sky* of the plough in 2 (above) jointed together to form a socket for the share



Two single-stilted Orkney ploughs of c. 1890. From a photograph lent by P. K. I. Leith



1. An Orkney single-stilted plough drawn by one ox, with a driver and an assistant pressing on the beam. The stubble indicates ploughing after a grain crop. *From a postcard photograph lent by P. K. I. Leith*



2. Ridging potatoes with a two-ox plough in Orkney, c. 1900. The ploughman is guiding the animals with reins. *From a postcard photograph lent by P. K. I. Leith*



1. Two Fair Isle delving teams. *From a photograph lent by J. Mann*



2. Harrowing the squarish 'rigs' in Fair Isle. *From a photograph lent by J. Mann*



1. The earliest illustration of a *cas chrom*, from John Home's *Survey of Assynt* (1774). By courtesy of the Scottish History Society



2. Detail of a *cas chrom* in use at Gairloch, Ross-shire, June 1954. Photograph by A. F. Gray, F.S.A. SCOT.



A print of Glasgow, c. 1800, with a two-stilted plough incorporating features of the *cram-nan-gadd*.
By courtesy of J. MacWhirter